



User manual

Cross 5/Cross 5XL

etac[®]
Creating Possibilities

75190 - 24-10-02 - Version 27

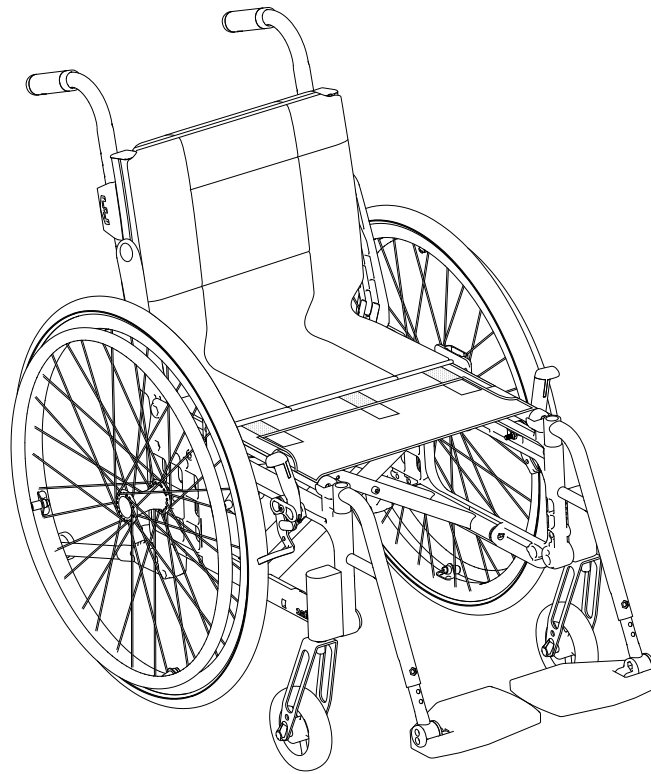

Etac Cross 5
Etac Cross 5XL

en



www.etac.com

MD CE

Contents

1. General – introduction	
Device description, Intended purpose, Intended user group, Intended environment, Intended application, Expected service life, Indications, Contraindications, Warnings, Declaration of conformity, Pre-purchase information, Adverse event, Customization, Combinations, Miscellaneous, Tools.....	3
2. Description	4
3. The chairs possibilities	5-8
4. Accessories	8-11
5. Settings	
Front seat height.....	12
Adjusting the front seat height by using the front fork attachment.....	12
Adjusting the front seat height by changing the position of the castor wheel.....	12
Adjusting the front seat height by changing the castor wheel/front fork.....	13-14
Front seat height table.....	13-14
Mounting the front fork.....	15
Setting the angle of the front fork attachment.....	15
Rear seat height.....	16
Adjusting rear seat height by changing rear wheel position or rear wheel size.....	16-17
Rear seat height table.....	18
Drum brake.....	19
User manual	20-31
Symbols and warnings.....	21
Transportation in vehicles.....	22
Handling.....	23-24
Settings seat comfort.....	25-26
Driving technique, maneuvering.....	27-30
Maintenance & Fault-finding chart.....	31
5. Settings (cont.)	
Seat angle.....	32
Seat depth.....	32
Seat comfort.....	32
6. Settings back support 3A	
Adjusting back support angle.....	33
Adjusting back support height and lumbar angle.....	34
Adjusting seat depth using lumbar angle.....	35
Fitting seat extender.....	35
Adjusting back support height and lumbar angle (two eccentric shafts).....	36
Adjusting seat depth using lumbar angle (two eccentric shafts).....	37
7. Settings back support mod. 2.....	38
8. Settings back support mod. 2B.....	39
9. Readjustments	
Brake, adjustment.....	40
Adjusting the brake block.....	41
Continuously angle-adjustable leg support (option).....	41
Amputee leg support (option).....	42
Anti-tips.....	42
Changing the camber angle.....	43
Adjusting the centre of balance.....	43
Handrims.....	44
Adjusting the distance of the handrim.....	44
Rear wheels with quick-release axle.....	44
10. Accessories - adjusting, handling	
Seat cushion and comfort wedge.....	45
Arm support, detachable, height adjustable.....	45
Arm support, flip-up, height adjustable.....	46
Positioning belt.....	46
Head support.....	47
Attachment for chest harness.....	48
11. Technical data	49-50
12. Service and maintenance	
Upholstery.....	51
Rear wheel/castor wheel, front fork attachment.....	51
Brakes.....	51
Washing the frame.....	51
Miscellaneous.....	51
13. Storage and Guarantees.....	52

1. General

Thank you for choosing an Etac product. In order to avoid damage during assembly, handling and use, it is important to read this manual and save it for future reference. You can also find it at www.etac.com. You can select your language via the "International" and "Local websites" link. Here you will also find other product documentation, such as prescriber information, pre purchase guide, and reconditioning instructions.

In this manual the user is the person sitting in the chair. The caregiver is the person helping the user.

Information on how people with impaired vision can access the manual can be found in our presales guide at www.etac.com.



To avoid damage or injury during handling and use, this manual should always accompany the device.

Device description

Cross 5 and Cross 5XL (hereafter also referred to as "the device" or "the product") are manual wheelchairs with cross-folded frames. They are adaptive and configurable through adjustable settings, options and accessories.

Intended purpose

Cross 5 and Cross 5XL are assistive devices intended for the alleviation of or compensation for a physical impairment due to an injury or disability. The device is designed for mobility. The device is designed for hand and/or foot propulsion and/or to be pushed and steered by an assistant.

Intended user group

The user group for the device is based on the individual's functional ability and not on a specific diagnosis, health condition or age. The device is intended for individuals with a height of 146 cm or more, or a mass of 40 kg or more. Secondary users of the device are attendants providing assistance and clinicians/technicians who set up the device.

Intended environment

The device is intended for indoor and outdoor use on levelled ground and accessible terrain. It is not to be exposed to salt water. The device has fixation points for transport in motor vehicle.

Intended application

The device is intended for short-term and long-term use. The device is intended to be used with a seat cushion. The device is intended for refurbish and reuse. Follow the instructions in "Reconditioning instruction, Etac manual wheelchairs" on www.etac.com.

Expected service life

The expected service life of the device is 10 years. Preventive maintenance is recommended. Lack of maintenance may reduce the expected service life of the device. For full information on the expected service life, see www.etac.com.

Indications

Indication for use is disability, including, but not limited to, an impaired ability to ambulate.

Contraindications

There are no known contraindications.

Warnings

Warnings describing a risk element for a specific action or setting of the device can be found in the relevant section.



A defective device must not be used. Risk of injury.



Do not leave the device in direct sunlight. A hot device may cause burns



Tipping risk. Inactivated anti-tips will increase the risk of injury. Activate the anti-tips to avoid the risk of tipping.



The device can be adjusted beyond safe use! Adjustments should only be carried out by a person who understands the use of the device.

Declaration of conformity

The device conforms with MDR (EU) 2017/745.

The device is tested and conforms with EN 12183 (which includes fire testing according to ISO 8191-2) and ISO 7176-19.

Pre-purchase information

Pre-purchase information can be found at www.etac.com.

Adverse event

In case of an adverse event occurred in relation to use of the device, it must be reported to your local dealer and the national competent authority in a timely manner. The local dealer will forward information to the manufacturer.

Customization

Actions outside the instructions and settings in the manual will invalidate the CE marking according to MDR 2017/745 and void the warranty.

Combinations

Risk-managed combinations between Etac devices and devices from other suppliers are presented in the combination list on www.etac.com.

Miscellaneous

Etac regularly improves its products. We therefore reserve the right to modify the products without prior notice. The dimensions given on drawings or other material are solely for guidance.

We are not responsible for printing errors or incomplete information.

Tools



Allen key
3, 4, 5, 6 mm



Box-end spanner
8, 10, 13, 24
mm



Spanner socket
19 mm



Screwdriver
Ph 2

In the centre spread of this manual you will find a removable section that contains user information.

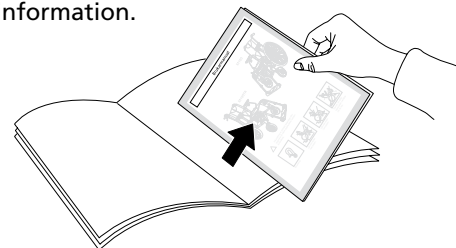

Explanation for list of points

- Applies to model
- ✳ Standard for this model

Cross 5 XL

Cross 5

2. Description

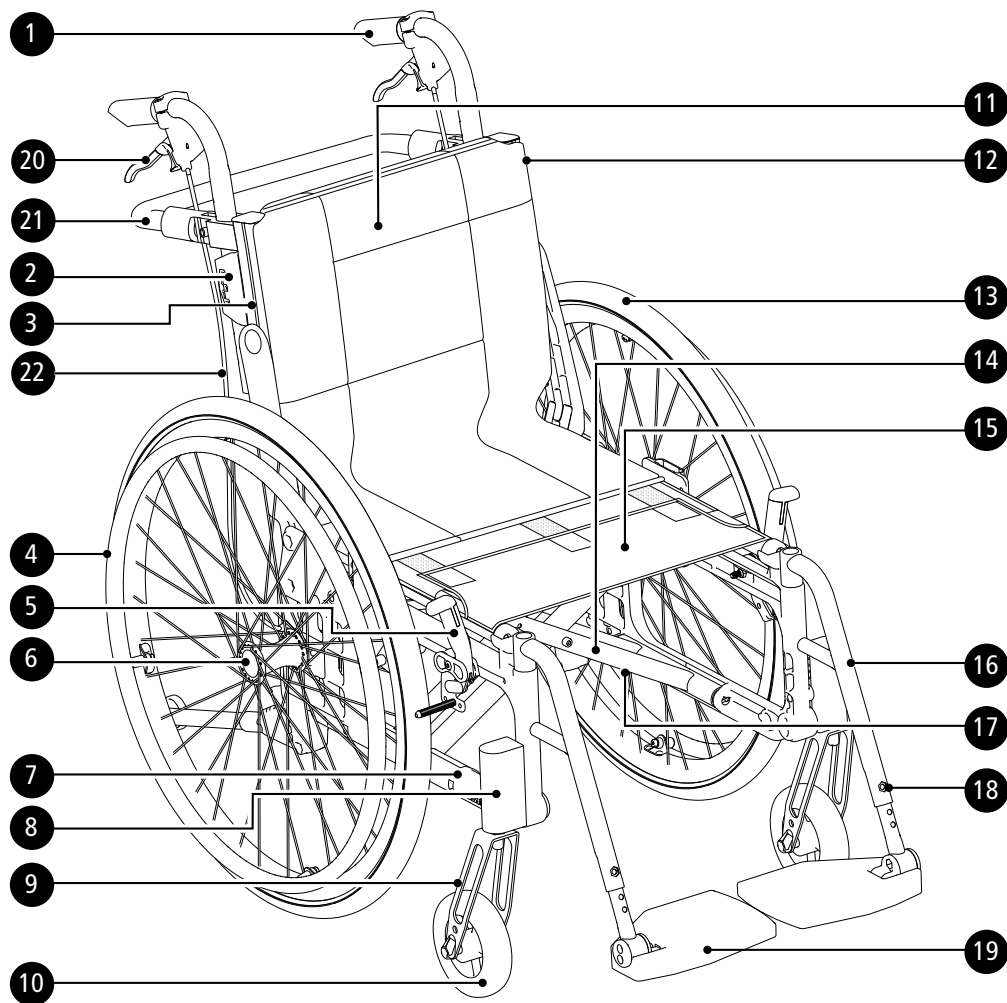

- 1. Push handles
- 2. Locking knob, push handles
- 3. Back rail
- 4. Handrim
- 5. User brake
- 6. Quick release hub
- 7. Side frame
- 8. Front fork attachment
- 9. Front fork
- 10. Castor wheel



- 11. Seat upholstery
- 12. Leg support
- 13. Serial number*
- 14. Locking knob, foot support
- 15. Foot support
- 16. Brake handle, drum brake
- 17. Cross brace
- 18. Brake wire, drum brake

*The device's date of manufacture can be read from the barcode on the device. The number 11 is shown below the barcode in brackets. The number combination after these brackets is the date of manufacture.



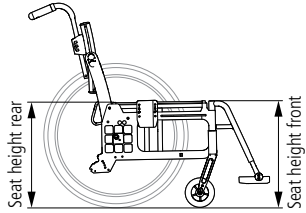
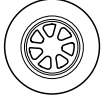
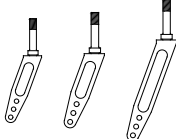
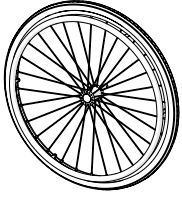

3. The chair's possibilities

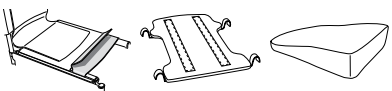
In the section "The chair's possibilities" you can see all the adaptations possible on the wheelchair. Variations may occur in different markets, e.g. as regards back support models. For more information, see www.etac.com or contact our customer service.

More so called "odd combinations" are available, for example rear wheels and castor wheels. Please, contact our customer service for more information.

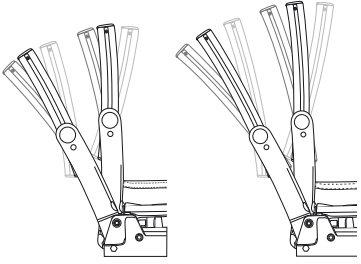
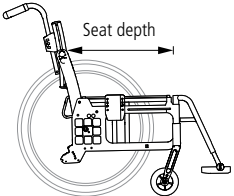
		Cross 5	Cross 5 XL		
Seat height		Front	34-56.5 cm	<input type="checkbox"/>	<input type="checkbox"/>
		Rear	34-53 cm	<input type="checkbox"/>	<input type="checkbox"/>
Seat angle		Max forward angle: 2 cm lower front than back (3°) Max backward angle: 6 cm higher front than back (9°)		<input type="checkbox"/>	<input type="checkbox"/>
Castor wheel		4" massive (max user weight 100 kg) 4" massive (max user weight 100 kg) 45 or 57 mm hub width		<input type="checkbox"/>	<input type="checkbox"/>
		5" massive (with Cross 5 XL max user weight 135 kg) 4" massive (max user weight 100 kg) 45 or 57 mm hub width		<input type="checkbox"/>	<input type="checkbox"/>
		6" semipneumatic 4" massive (max user weight 100 kg) 45 or 57 mm hub width		<input type="checkbox"/>	<input type="checkbox"/>
		6,5" massive		<input type="checkbox"/>	<input type="checkbox"/>
		7" massive soft		<input type="checkbox"/>	<input type="checkbox"/>
		8" semipneumatic 57 mm hub width or 200x38 45 (solid)		<input type="checkbox"/>	<input type="checkbox"/>
Front fork		Extra short (two alternative wheel height positions) steel, for 57 mm hub width		<input type="checkbox"/>	<input type="checkbox"/>
		Short (three alternative wheel height positions). Thickness of 3 or 4 mm steel, for 57 mm hub width		<input type="checkbox"/>	<input type="checkbox"/>
		Medium (three alternative wheel height positions). Thickness of 3 or 4 mm steel, for 57 mm hub width		<input type="checkbox"/>	<input type="checkbox"/>
		Long steel, for 57 mm hub width		<input type="checkbox"/>	<input type="checkbox"/>
		XS, aluminium, for 45 mm hub width		<input type="checkbox"/>	<input type="checkbox"/>
		S, steel, for 45 mm hub width		<input type="checkbox"/>	<input type="checkbox"/>
		M, steel, for 45 mm hub width		<input type="checkbox"/>	<input type="checkbox"/>
Rear wheel		20" (C5 or C6)		<input type="checkbox"/>	<input type="checkbox"/>
		22" (C5 or C6)		<input type="checkbox"/>	<input type="checkbox"/>
		24" (C5 or C6)		<input type="checkbox"/>	<input type="checkbox"/>
		24" Carbon (not in combination with drum brakes)		<input type="checkbox"/>	<input type="checkbox"/>
		25" Maxx		<input type="checkbox"/>	<input type="checkbox"/>
		26" C5		<input type="checkbox"/>	<input type="checkbox"/>
Handrims		Aluminium		<input type="checkbox"/>	<input type="checkbox"/>
		Stainless steel		<input type="checkbox"/>	<input type="checkbox"/>
		Plastic coated		<input type="checkbox"/>	<input type="checkbox"/>
		Cellular rubber (not in combination with drum brakes) (not for C6 or Maxx)		<input type="checkbox"/>	<input type="checkbox"/>
		Titanium (not in combination with drum brakes) (not for C6 or Maxx)		<input type="checkbox"/>	<input type="checkbox"/>
Camber angle		2°		<input type="checkbox"/>	<input type="checkbox"/>
		0°		<input type="checkbox"/>	<input type="checkbox"/>
Seat		Black fabric		<input type="checkbox"/>	<input type="checkbox"/>
		hard seat		<input type="checkbox"/>	<input type="checkbox"/>
		ECS: A fixed seat/back support system with anatomically shaped cushions, detachable		<input type="checkbox"/>	<input type="checkbox"/>

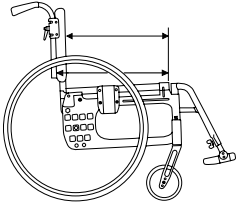
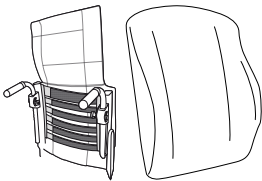
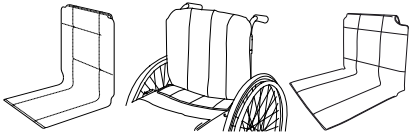
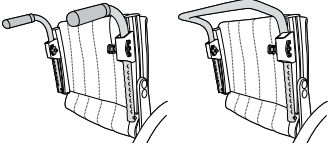
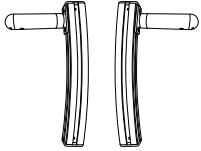
3. The chair's possibilities

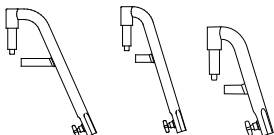
			3A	3A high			
Back support 3A (one eccentric washer) / Back support 3A high (one eccentric washer)					●	●	
		Height	32-45 cm	38-51 cm			
		Back support angle	-5° - +20°	-5° - +20°			
		Lumbar angle	-16° - +16°				
Seat depth		Short frame 36-42 cm (triangular 36-49 cm)				●	●
		Long frame 42-48 cm (triangular 42-55 cm)				●	●
Back support mod. 2		Height 30-45 cm	Standard			●	
		Angle -5° - +15°	Widened			●	
Seat depth back support mod. 2		Short frame 36-42 cm. Long frame 42-48 cm. Functional: Short frame 42-48 cm. Long frame 48-54 cm.				●	
Back support upholstery		Adjustable upholstery				●	●
Back support cover		Standard				●	●
		Comfort				●	●
		Tidy, water-repellent, wipeable				●	●
Push handles/ Bow handle		Height adjustable at intervals of 2 cm.	Push handles			●	●
		Detachable.	Bow handle			●	●
Fixed push handles		Right/left fits back support 3A				●	●
Fixed back support with fixed push handles, 2B		Height, low back 35-40 Height, high back 42,5-47.5 Angle -5° - +15°				●	
Leg supports, detachable swing-away		Normal knee angle				●	●
		Narrow angle (only together with 5" castor)				●	●
		Narrow angle, short				●	

3. The chair's possibilities

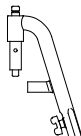
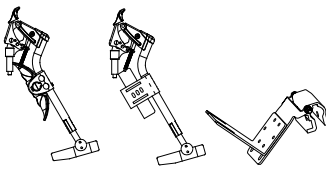
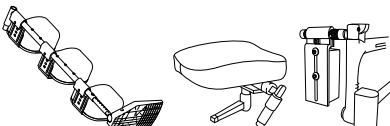
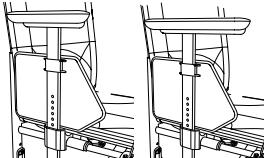
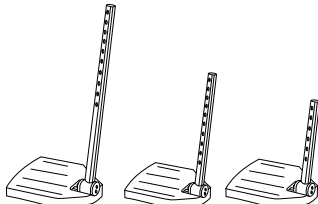
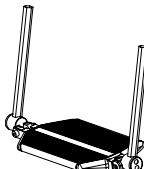
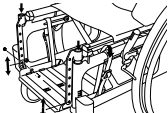
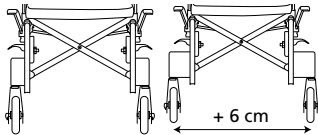
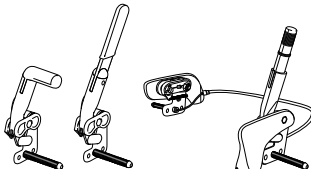
			Cross 5	Cross 5 XL
Leg supports, lockable		Normal knee angle	●	●
		Narrow angle	●	
		Narrow angle, short	●	
Leg supports, angle adjustable		Elevating with foldable calf support from 40 cm seat width	●	●
		Elevating with attachment and padded foldable calf support.	●	●
		Elevating with flip-up attachment and calf support.	●	●
Leg supports, other		Plaster leg support	●	●
		Amputee leg support	●	●
		Amputee weight	●	●
Arm support		Short 25 cm	●	●
		Long 35 cm	●	●
Foot support		Std Max length: 51 cm. Min length: 33 cm.	●	●
		Extended attachment tubes +10 cm	●	●
		Shorter attachment tubes -8 cm	●	
		One-piece foot support	●	●
		One-piece foot support complete for 35-37,5 seat width, adjustable in angle, settable height and depth	●	
Front fork attachment		Low widened	●	●
		Standard H100 or H142 (for fork with 45 mm hub width)	●	●
		widened 6 cm H100	●	●
Brakes		Angled handle	●	●
		Extended handle	●	●
		Single hand brake (standard or angled handle)	●	●

3. The chair's possibilities

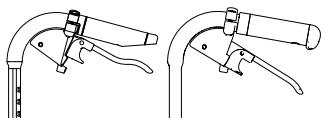
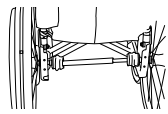
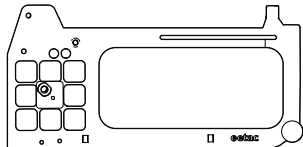

			Cross 5	Cross 5 XL
Attendant brake		Brake handle 75 mm grip	●	●
		Brake handle 100 mm grip	●	●
Single hand drive		For right or left side. Telescoping axle, easy to remove when folding. (Not in combination with drum brakes)	●	●
Frame colour	01 = Black 92 = White 93 = Dark blue		●	●
Frame active		Without anti-tip attachment. Colour: black 01, white 92	●	

4. Accessories





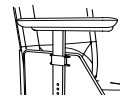
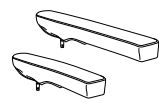
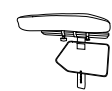
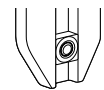
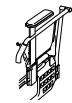



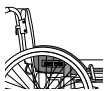
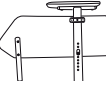
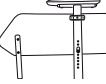
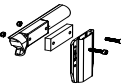

Assembly instructions are always provided with accessories when they are supplied by Etac.

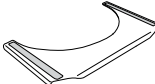
Instructions are also available on our website, www.etac.com

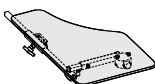
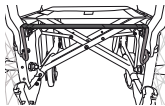



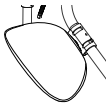
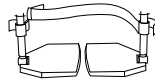

Settable = Adjusted using tools. **Adjustable** = Adjusted without tools.

			Cross 5	Cross 5 XL
Arm support	height-adjustable 25 cm long, solid top, black		●	●
	height-adjustable 38 cm long, solid top, black		●	●
	Foldable short 26 cm		●	●
	Foldable short 36 cm		●	●
Arm support cover	detachable, 25 or 38 cm long padded or gel, dark grey plush or black Hygiene		●	●
Arm support cushion Hemi	swing-away for mounting on long arm supports		●	●
Arm support locking Kit	A locked arm support is not detachable but its height can be adjusted freely.		●	●
Arm support foldable	height adjustable or fixed height (not with telescopic anti-tips. Use anti-tips for Etac Cross 5 Active, item no 25177)		●	●
Side guard	black		●	●
Filler cushion	Reduces the width between the arm supports			



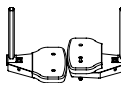
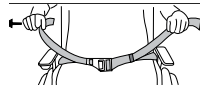
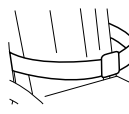

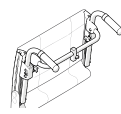
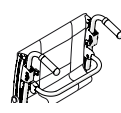
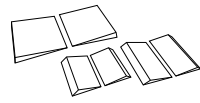

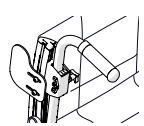
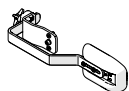

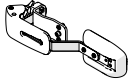
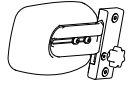
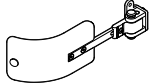

4. Accessories

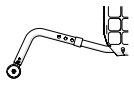
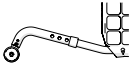
			Cross 5	Cross 5 XL
Mudguard	right and left		●	●
Thigh support			●	●
Thigh support	With soft cushion		●	●
Widening kit	to extend handrims, brake and arm supports 5 mm on each side		●	●
Tray	transparent, fits onto long arm support		●	●
Hemi tray	transparent, width 35-50 cm. Can be fitted onto short or long arm supports.		●	
Anti-slip device	for the Hemi tray		●	
Tray Hemi/Communication	tip up right/left		●	●
Seat extension	To be used together with triangular back		●	●
Seat cushion	dark grey plush and black velour, 56 cm, cut according to seat depth set, washable		●	●
Seat cushion Tidy	water-repellent, wipeable		●	●
Comfort wedge	for the cushion, evens out the front part of the seat		●	●
Cover for calf support	on angle adjustable leg support model 3, black Hygiene		●	●
Calf strap	detachable, black nylon, adjustable in length		●	●
Padding	for calf strap		●	●
Calf support	Plush. To be mounted/adjusted with velcro		●	●

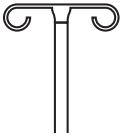
4. Accessories

			Cross 5	Cross 5 XL
Heel straps	black nylon, adjustable length		●	●
Foot support, padding	For foot support with depth 13 cm		●	●
	For solid, angle adjustable foot support		●	●
Extended foot support	fits onto the existing foot support, from seat width 40-55 cm		●	●
Positioning belt	two pieces, with snap-lock, fixing points on the wheelchair frame		●	●
Seat belt	with snap lock		●	●
Head support	Adjustable in height, depth and angle.		●	●
	With side support. Adjustable in height, depth and angle. Hygiene cover		●	●
Head support attachment	Cross back 3A, mod 4		●	●
Head support attachment	To be mounted on bow handle		●	●
Cross brace	Cross back 3A. With snap lock		●	✳
Cross brace	Cross back 2. With snap lock		●	●
Back wedge	Three different sizes, attached with Velcro. Provides support and contour. The wedges can also be combined with other accessories and cut to desired size. Several wedges can also be put together.		●	●
Back wedge	length 15 and 30 cm, attached with Velcro		●	●
Side cushion	Provides gentle lateral support. Used when the trunk support is too stabilising. (Combined with arm support and, if necessary, side stop)		●	●
Side stop	Straight or angled. Combined with wedge or side support cushion. Creates a more distinct stop and holds the wedge or side support cushion in place.		●	●
Trunk support	Settable in height, depth and width. Detachable		●	●

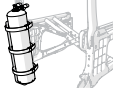
4. Accessories

			Cross 5	Cross 5 XL
Trunk support	Swing-aside and detachable. Settable in height, depth and width		●	●
Trunk support	Cross back 3A, PUR or Hygiene		●	●
Trunk support	Cross back 3A, swing-aside, medium or large cushion		●	●
Anti-tips	telescopic, foldable, settable height, adjustable length and angle (not with foldable arm supports)		●	●
Anti-tips	For Etac Cross 5 Active seat height 37-55 cm		●	
Aluminium anti-tips	For Etac Cross 5 Active seat height 34-37cm		●	●
Cane holder	two parts, one of which is an elasticated section that is fastened around the cane		●	●
Drip stand	Bracket and stand		●	●
Spoke guard	with grey or yellow print		●	●
Tetra quickrelease adapter	for persons with reduced hand function		●	●
Tool kit			●	●
Oxygen holder	Max. weight capacity 5 kg		●	●
Combinations	Power assist		●	●
	Head support		●	●
	Seat cushions		●	●
	Belts and harnesses		●	●

5. Settings

Front seat height

The front seat height may be adjusted by:

- Using the front fork attachment, adjustable in height and angle.
- Changing the position of the castor wheel.
- Changing the front fork.
- Changing the castor

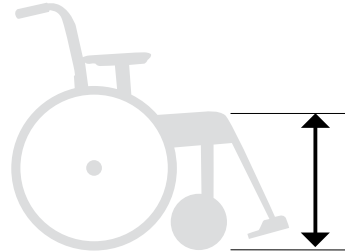

Tipping risk. Inactivated anti-tips will increase the risk of injury. Activate the anti-tips to avoid the risk of tipping.

Adjusting the front seat height by using the front fork attachment

Loosen the screws (A and B). Set the desired seat height by measuring from the floor to the seat upholstery and tighten the screws on one front fork mounting. Use the position markings as a reference for adjusting the height on the other side. Tighten the other mounting. Check and adjust so that the mountings are perpendicular. (See section 'Angle

setting of front fork mounting'.) Fine-tune the height of the front fork mountings so that both wheels are flush with the floor.



Tipping risk. Inactivated anti-tips will increase the risk of injury. Activate the anti-tips to avoid the risk of tipping.

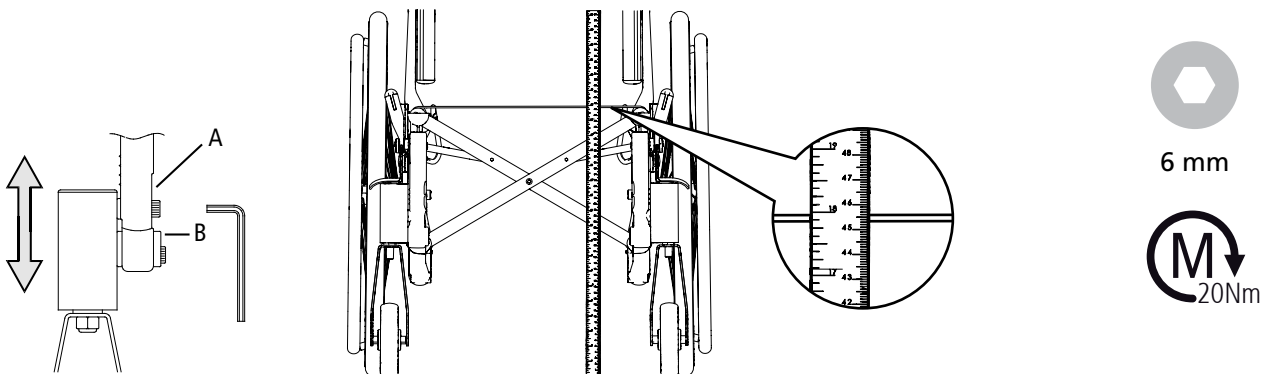

Adjusting the front seat height by changing the position of the castor wheel

See also section "Front seat height table".



Tipping risk. Inactivated anti-tips will increase the risk of injury. Activate the anti-tips to avoid the risk of tipping.

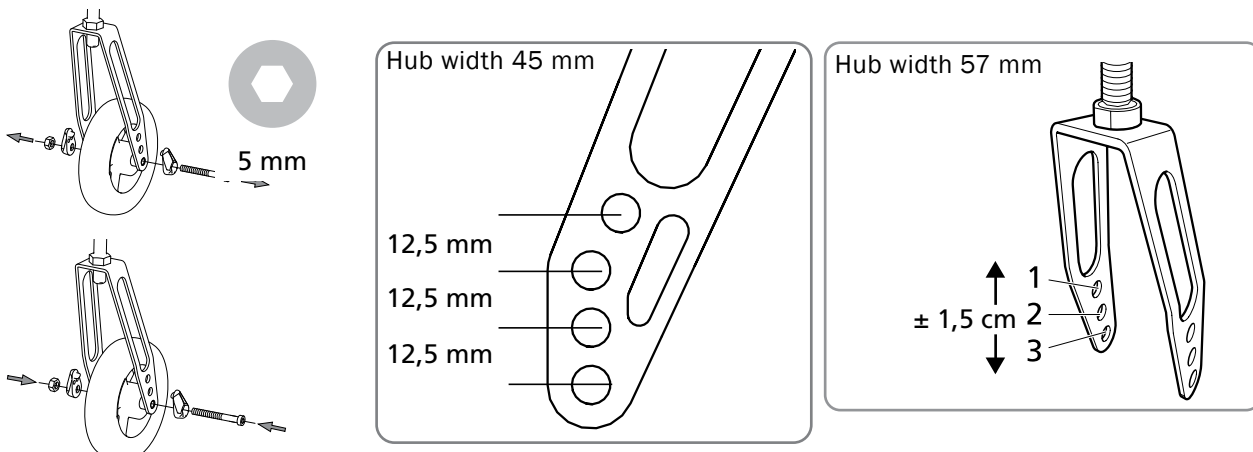

5. Settings

Cross 5	Cross 5 XL
●	●
●	●

Adjusting the front seat height by changing the castor wheel/front fork

See sections "Adjusting the front seat height by changing the position of the castor wheel" and "Front seat height table".



5 mm



19 mm

Tipping risk. Inactivated anti-tips will increase the risk of injury. Activate the anti-tips to avoid the risk of tipping.

Front seat height table

Front seat height table 57 mm castor hub													
Castor position													
		Extra short fork (steel)			Fork Short (steel)			Fork Medium (steel)			Fork Long (steel)		
Castors		1	2	3	1	2	3	1	2	3	1	2	3
Low Front fork attachment	4"*		340-380	355-395									
	5"***	335-365	350-385	365-400	360-400	375-415	390-430						
Standard/Wide front fork attachment	5"***				375-415	390-430	405-445	430-460	450-480	460-490			
	6"					400-440	415-455	450-470	460-490	470-500			
	6½"					410-450	425-465	460-480	470-490	480-510	505-525	515-535	525-555
	7"								475-495	485-515			530-560
	8"***								480-510	490-520		525-545	535-565

* Maximum user weight 100 kg

For correct setting of the front fork attachment: Max. backward inclination 6 cm higher front than rear (9°), max. forward inclination 2 cm lower front than rear (3°).

** Possible in balance position 4-6 with 3° backward inclination and Std leg support. Make sure the fork/castor wheel can rotate freely without hitting the wheelchair or user. For 8x2" castor wheels, use the Transit fork (gives a seat height of 47-51 cm).

*** With Cross 5 XL max user weight 135 kg.

5. Settings

Cross 5	Cross 5 XL
●	●
●	●

Adjusting the front seat height by changing the castor wheel/front fork

See sections "Adjusting the front seat height by changing the position of the castor wheel" and "Front seat height table".



5 mm



19 mm

Tipping risk. Inactivated anti-tips will increase the risk of injury. Activate the anti-tips to avoid the risk of tipping.

Front seat height table 45 mm castor hub

		Castor position											
		Fork XS (alu)			Fork S (steel)				Fork M (steel)				
	Castors	1	2	3	1	2	3	4	1	2	3	4	
Low, widened	4"*	340-360	343-383	355-395									
	5"***				345-385								
H100	5"***				360-400	373-413	385-425	398-438	410-450	423-463	435-475	448-488	
	6"					385-425	398-438	410-450	423-463	435-475	448-488	460-500	
	8"***							435-475	448-488	460-500	473-513	485-525	
H142	8"								488-528	500-540	513-553	525-565	

*Maximum user weight 100 kg.

For correct adjustment of the front axle mount: Max backwards angle 6 cm higher than rear (9°), max forward angle 2 cm lower than rear (3°).

More combinations than the above may be possible.

** Works in balancing 4-6 with 3° backward angle and Std leg support. Make sure that the axle/castor wheel can rotate freely without hitting a wheelchair or user.

*** With Cross 5 XL max user weight 135 kg.

5. Settings

Mounting front fork

- Pull out the cover plug (A) and unscrew the retaining nut (B). Pull out the front fork and put the bevelled washer (C) and the bearing on the new fork.
- Mount the washers and bearings in the front fork attachment as illustrated. Washer (C) is mounted with the bevelled side towards the front fork. Washer (D) on top under the retaining nut.
- Tighten the retaining nut until it cannot be turned any more. Loosen it 1/2-1 turn. The spring washer then has the correct tension. It reduces the risk of the castor starting to "wobble".
- Mount the cover plug.

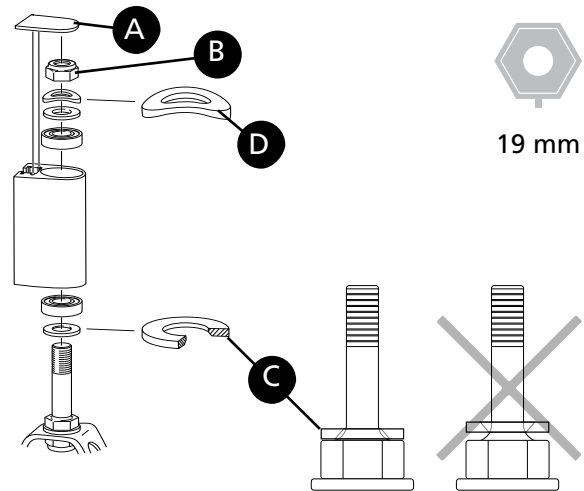

Setting the angle of the front fork attachment

The correct angle setting is important for the wheelchair's manoeuvrability.

Unscrew the lower attachment screw (A) about 2 turns so that the shaft (C) moves freely inside the sleeve.

Insert the Allen key in the hole (B) and turn until the attachment is 90° to the floor. Always start from a position that enables the wheel to move forward in

the rotation (D). Hold the shaft in place while the lower attachment screw is tightened.

 **Tipping risk.** Inactivated anti-tips will increase the risk of injury. Activate the anti-tips to avoid the risk of tipping.

 **Keep your eye on something vertical,** e.g. a door frame or table leg, while setting the angle.

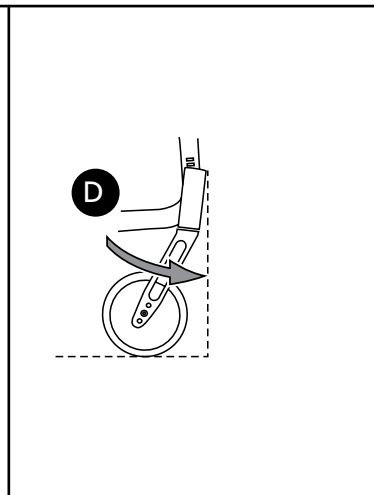
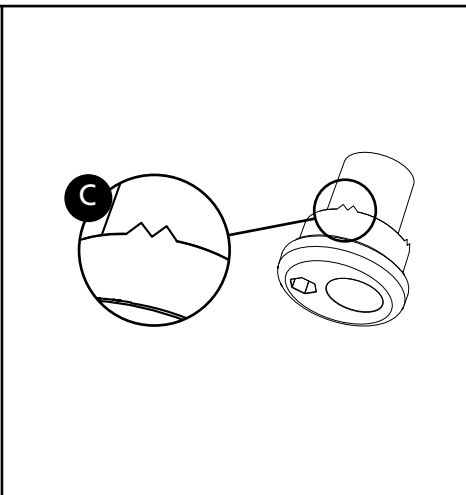
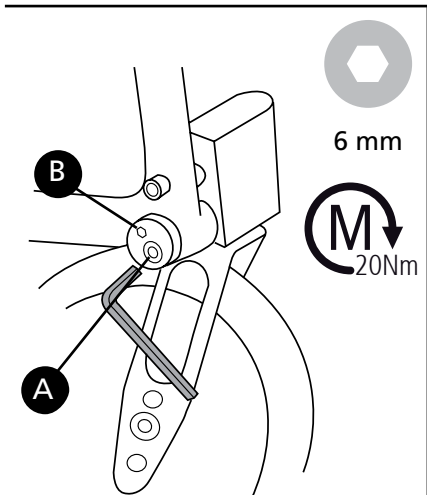

5. Settings

Cross 5
Cross 5 XL

Rear seat height

Rear seat height can be adjusted by:

- Changing the position of the rear wheel in the frame.
- Changing the position of the rear wheel in the camber washer.
- Changing the rear wheel.

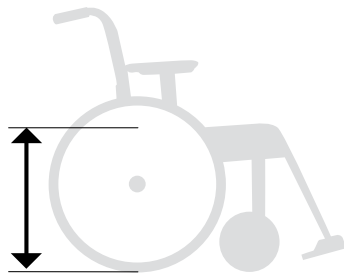

 Tipping risk. Inactivated anti-tips will increase the risk of injury. Activate the anti-tips to avoid the risk of tipping.

Adjusting rear seat height by changing rear wheel position or rear wheel size

1. Remove the rear wheel.
2. Unscrew the nut.
3. Reassemble in desired position (see table in section "Rear seat height table").

 Tipping risk. Inactivated anti-tips will increase the risk of injury. Activate the anti-tips to avoid the risk of tipping.

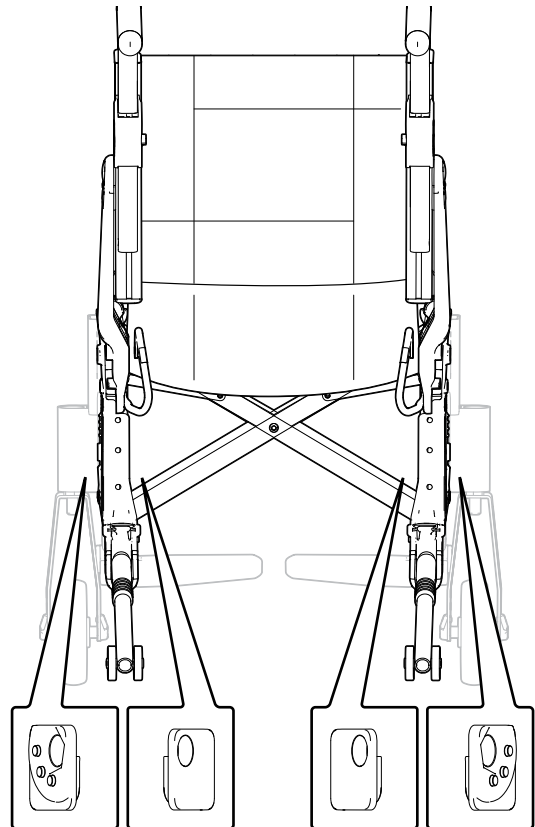
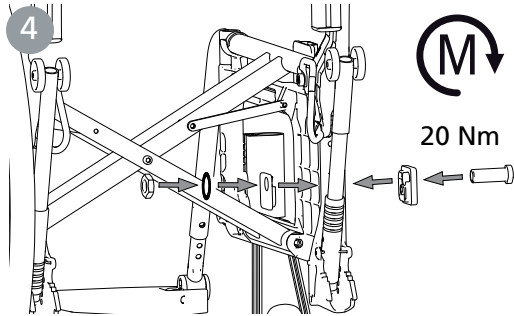
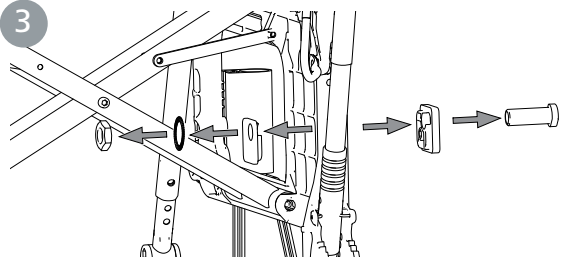
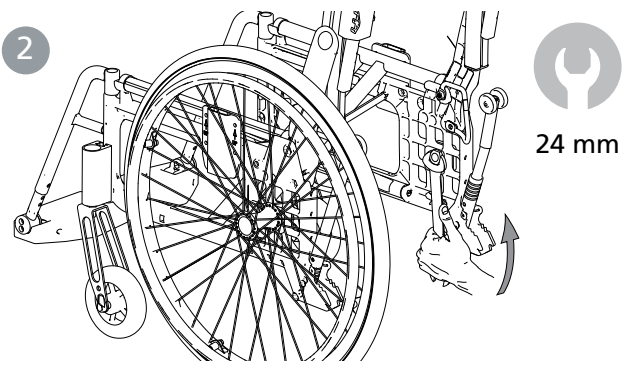
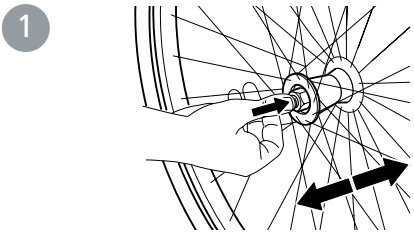

5. Settings

Cross 5	Cross 5 XL
●	●

 When attaching the rear wheels, make sure that the quick-release button fully returns. Test by pulling the wheel. Risk of injury.

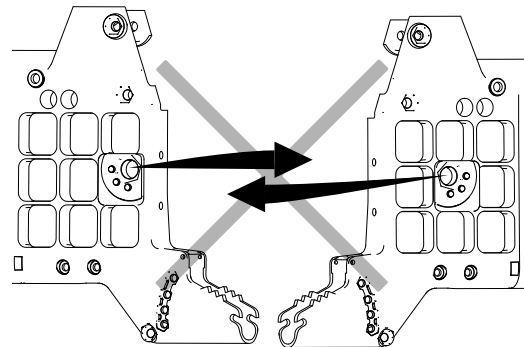
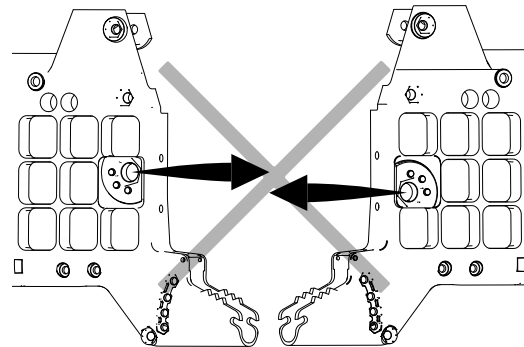
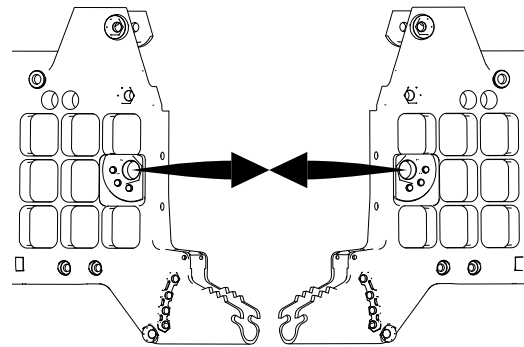
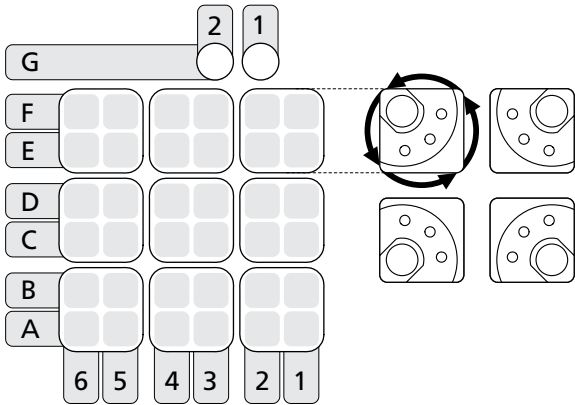

Assembly in pos. G1 & G2

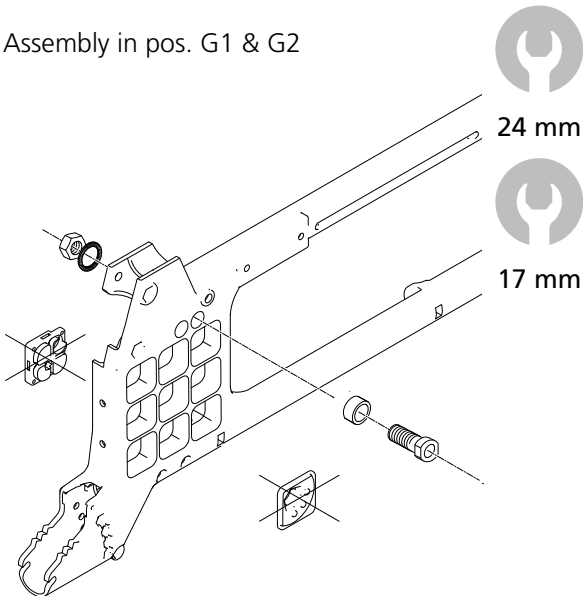

Assembly 0° Camber

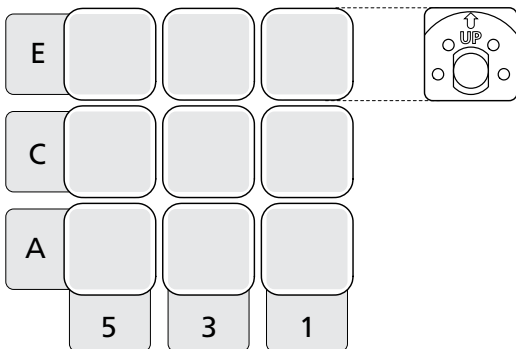

5. Settings

Rear seat height table

Rear wheel position, height

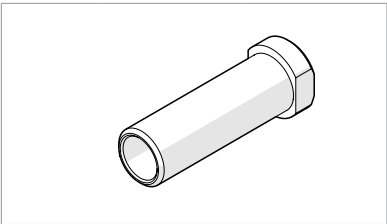
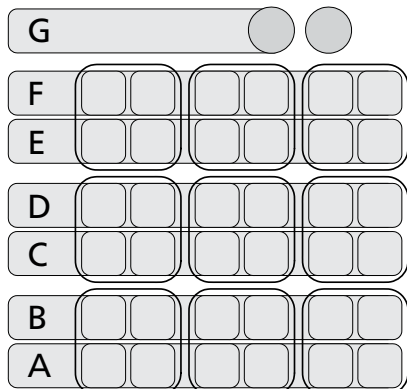

Hub C5

	Wheel	Seat hgt	Distance
Position A	20"	46	4.5
	22"	48.5	7.0
	24"	51	9.5
	26"	53,5	12
Position B	20"	44	6.5
	22"	46.5	9.0
	24"	49	11.5
	26"	51,5	14
Position C	20"	42	8.5
	22"	44.5	11.0
	24"	47	13.5
	26"	49,5	16
Position D	20"	40	10.5
	22"	42.5	13
	24"	45	15.5
	26"	47,5	18
Position E	20"	38	12.5
	22"	40.5	15
	24"	43	17.5
	26"	45,5	20
Position F	20"	36	14.5
	22"	38.5	17
	24"	41	19.5
	26"	43,5	22
Position G	20"	34	16.5
	22"	36.5	19
	24"	39	21.5
	26"	41,5	24

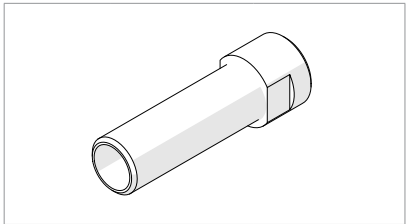

Hub C6

	Wheel	Seat hgt	Distance
Position A	20"	46	4.5
	22"	48.5	7.0
	24"	51	9.5
	25"	52,5	11
	26"	53,5	12
Position B	20"	44	6.5
	22"	46.5	9.0
	24"	49	11.5
	25" Maxx	50,5	13
	26"	51,5	14
Position C	20"	42	8.5
	22"	44.5	11.0
	24"	47	13.5
	25" Maxx	48,5	15
	26"	49,5	16
Position D	20"	40	10.5
	22"	42.5	13
	24"	45	15.5
	25" Maxx	46,5	17
	26"	47,5	18
Position E	20"	38	12.5
	22"	40.5	15
	24"	43	17.5
	25" Maxx	44,5	19
	26"	45,5	20
Position F	20"	36	14.5
	22"	38.5	17
	24"	41	19.5
	25" Maxx	42,5	21
	26"	43,5	22
Position G	20"	34	16.5
	22"	36.5	19
	24"	39	21.5
	25" Maxx	40,5	23
	26"	41,5	24

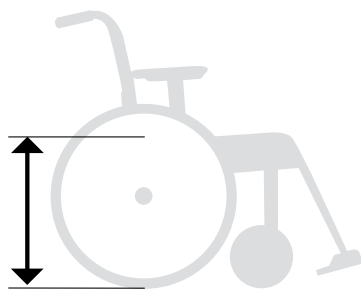

Seat height, rear

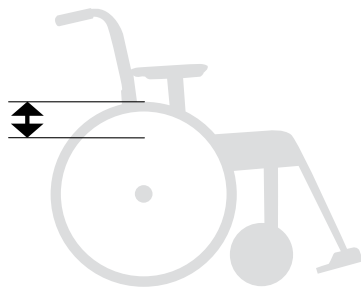

Distance wheel-seat

5. Settings

Drum brake

Cross 5	Cross 5 XL
●	●

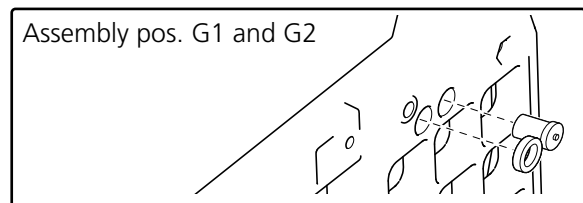
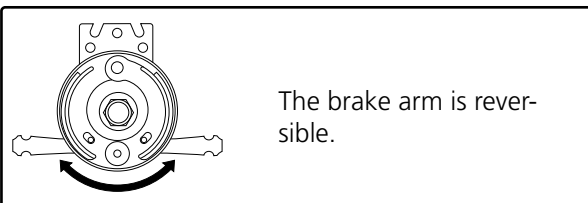
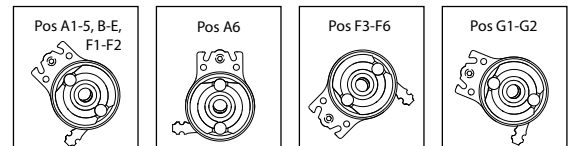
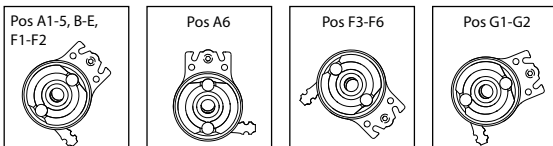
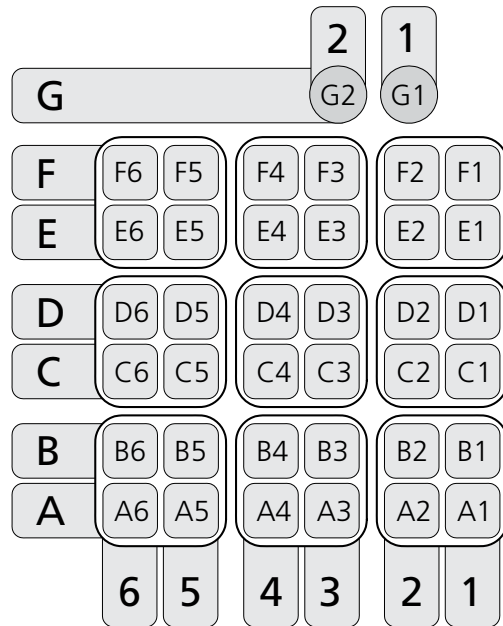
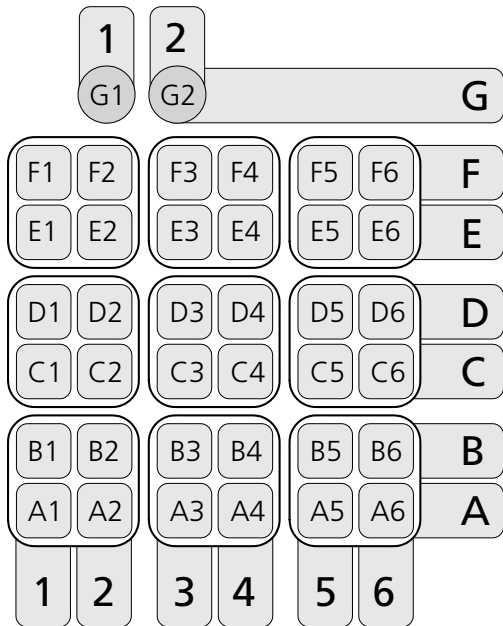
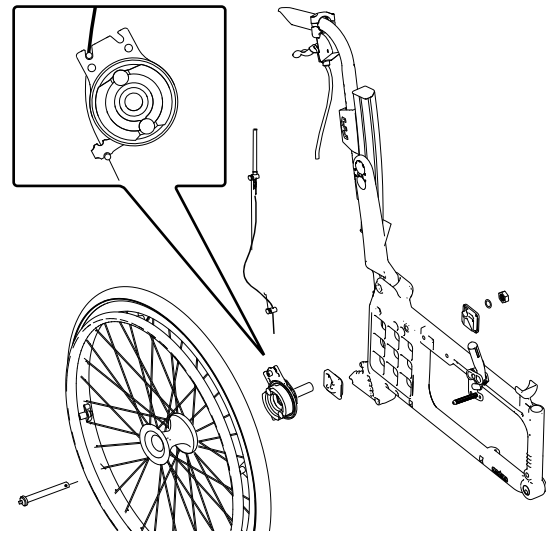
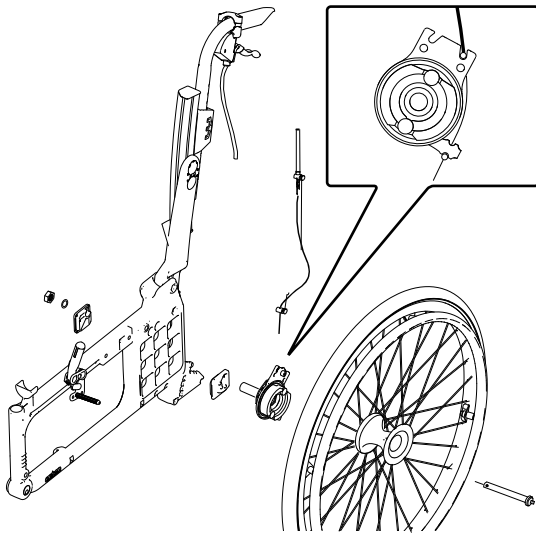

To adjust the brakes, loosen nut (A). Loosen/tighten screw (B) in order to reach proper brake function. Tighten the nut (A). This adjustment should be done when the brakes are not working properly.

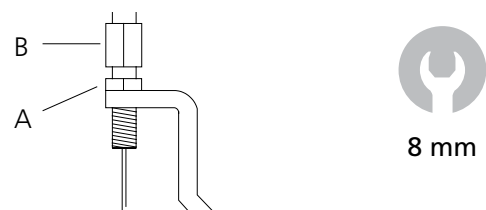

User manual

75190.26 24-10-02



This part of the manual (User manual) should be torn out and at all times follow the wheelchair. This as it contains important user information.

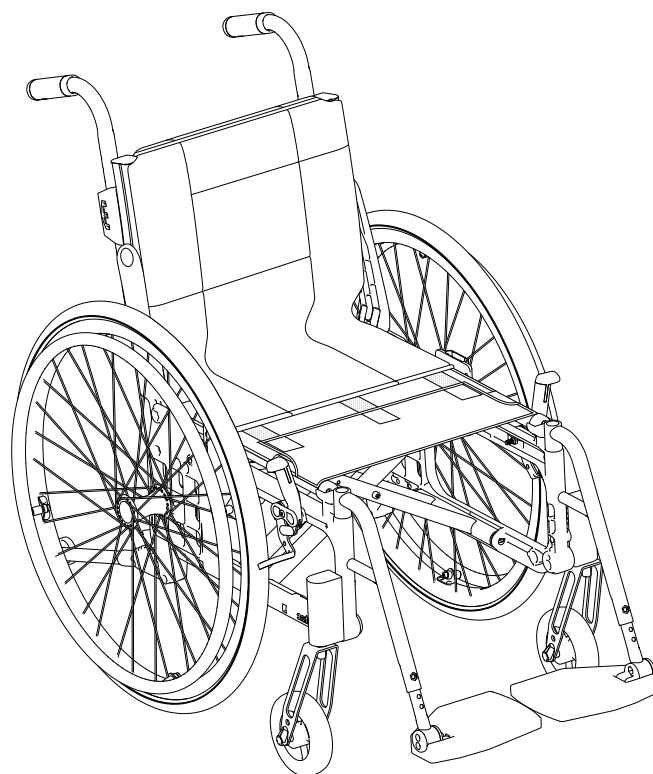
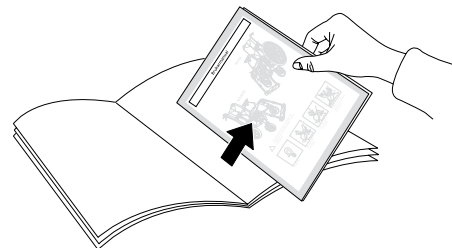









Etac Cross 5
Etac Cross 5 XL

User manual

Symbols and warnings

Symbols

These symbols appear in the manual.

	Warning, precaution or limitation		Useful advice and tips.		Material for recycling
	Click on the icon or scan the QR code for video		Showing 1 of two options		Showing 2 of two options
	Showing 1 of three options		Showing 2 of three options		Showing 3 of three options







Symbols

These symbols appear on the device.

	Tipping risk. Inactivated anti-tips will increase the risk of injury. Activate the anti-tips to avoid the risk of tipping.		Removable part, do not lift!		Anchoring. Fixing points for the clamping system for transport in motor vehicles.
	The product complies with ISO 7176-19.				

Product label

Article information.

Product	Serial no.	Bar code acc. to GS1-128 GTIN-14 and serial no.*	
 XXXXXXXXXXXX	 XXXXXXXXX		
 Max XXX kg	 XXXXXXXX	 YYMMDD	
Maximum user weight	Item number	Date of manufacture	

*The device's date of manufacture can be read from the barcode on the device. The number 11 is shown below the barcode in brackets. The number combination after these brackets is the date of manufacture.

User manual

Transportation in vehicles

Etac's wheelchairs are tested in accordance with ISO 7176-19 (see "Tests and guarantees" section in the manual).

Etac recommends in the following order:

1) The user transfers to a seat in the vehicle and uses the vehicle's 3-point belt while travelling. The wheelchair is then placed in the boot or safely in the back seat so that it cannot overturn or roll.



- If possible, the wheelchair should be placed in the boot.
- If the wheelchair is placed in the back seat, make sure it can not overturn or roll. If possible secure the wheelchair with the car's safety belt.

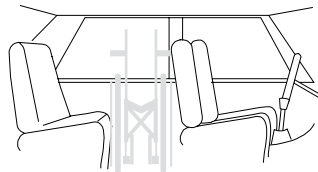

2) The wheelchair is secured facing forwards in the vehicle as per this manual, the user uses a separate 3-point belt that is secured in the vehicle.



This is the way the wheelchair is tested and approved according to ISO 7176-19:

- Clamping device UNWIN_WWR/ATF/K/R according to ISO 10542
- Three point strap 907523, Klippan Safety AB.
- Parking brakes activated
- Anti-tip guards activated
- Head support bracket 3A and head support. (Cross 5/5XL)
- Cross bar (Cross 5XL)
- Rear wheels with handrims.

Securing

- Securement points rear must be used.
- Restraining device must not be put through the wheels or around the back tubes.
- Accessories that can be detached without tools (excluding arm supports, leg supports, and positioning accessories) must be removed and clamped
- If head support is mounted other than with head support bracket 3A, cross bar must be used.
- Cross 5XL must have cross bar regardless of which way the head support is mounted.

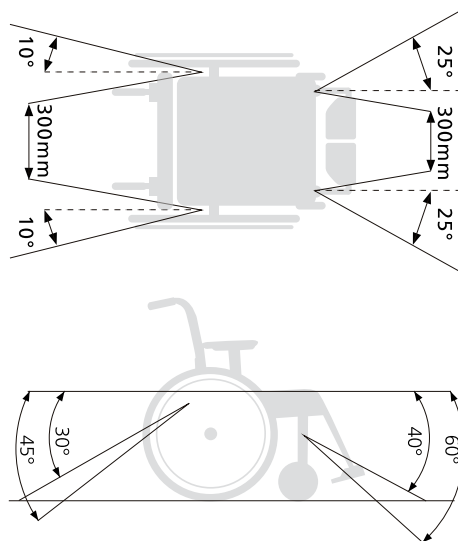
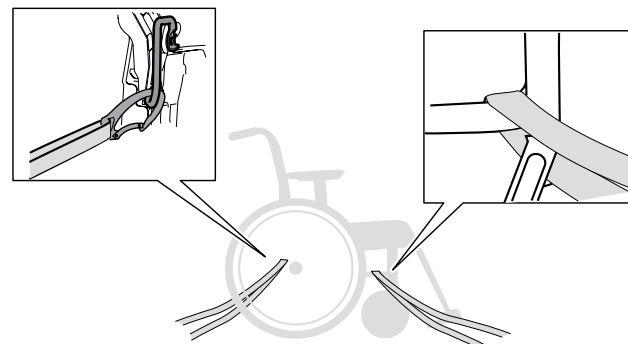
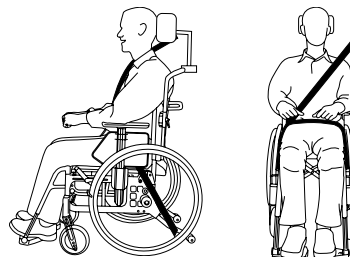

3) According to directive 2001/85/EC, appendix VII, point 3.8.3. there are specially marked wheelchair locations in vehicles that permit transport with a wheelchair facing in the opposite direction of travel. If this means of travel is used, the user/carer must be aware while travelling, prepared for sudden movements and have the capacity to maintain a safe sitting position throughout the entire journey. The user's disabilities must not be of such an extent that he/she is not able to hold onto the handles fitted in the vehicle when there are changes of speed or direction.



- Parking brakes activated.
- Anti-tip guards activated.
- Head support.
- Positioning belt should be used.
- Accessories that can be detached without tools must be removed and clamped.

User manual

Handling



Unfolding

- Push down on one side of the seat frame, using the whole of the flat of the hand.
- Lower the foot supports.



Do not hold the seat tube when unfolding the wheelchair. Risk of injury.

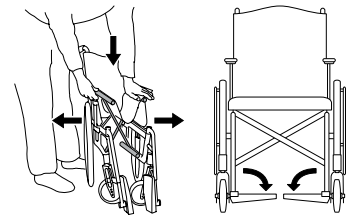

Folding

- If a bow handle and/or cross brace is mounted they should be removed.
- Flip up the foot supports.
- Lift up the seat.

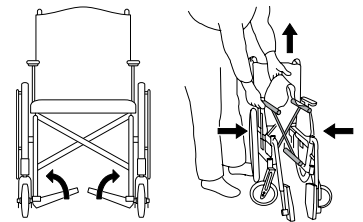

Rear wheel with quick release



When attaching the rear wheels, make sure that the quick-release button fully returns. Test by pulling the wheel. Risk of injury.

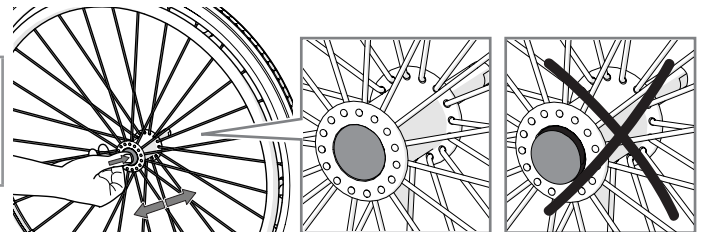

Anti-tips

- The anti-tips can be flipped up.

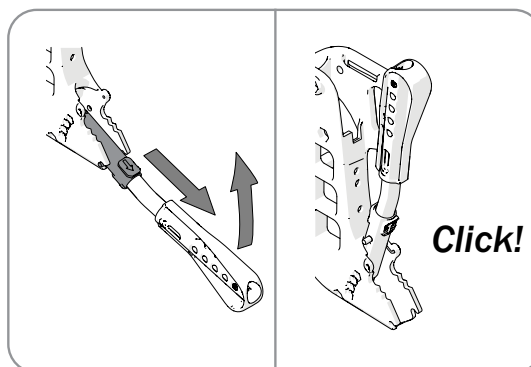

- Ensure the locking function works properly when activating the anti-tip.

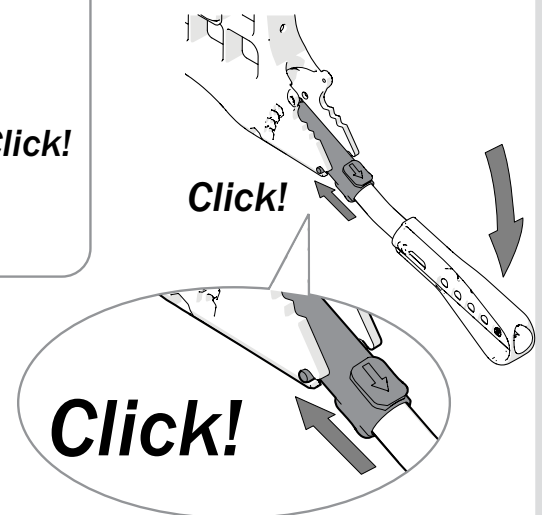

- After any adjustments on your wheelchair, always ensure that you check the function of the anti-tips. If necessary to adjust, please contact your dealer or your Technical Aids Centre.

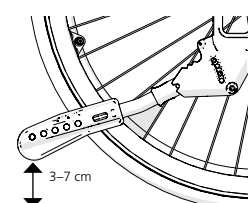

User manual

Leg support

The leg supports can be lifted off/swung to the side if needed. Lockable leg supports by pushing the red button (A).

To fasten the lockable leg supports press down on the red button (A), put the leg support into place and release the button. The leg support is now locked (B).

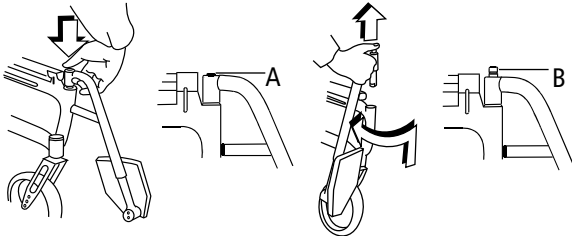

Check that the lockable leg supports are locked before lifting. Risk of injury.

Push handles/bow handle, height adjustable

Loosen the knobs/release the locking handles. Set desired height. Ensure that the push handles are locked in the correct position, tighten the knobs/lock the locking handles.

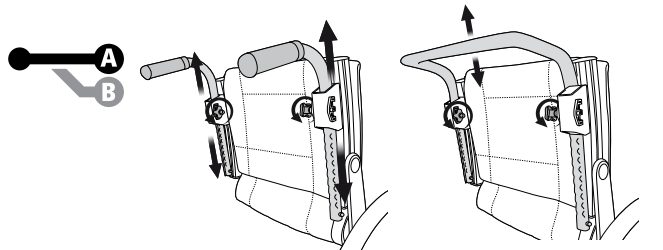

Make sure the knobs/locking handles are properly tightened/locked and that the safety buttons have popped out below the brackets.



The bow handle must be removed before the chair can be folded.

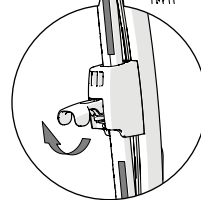
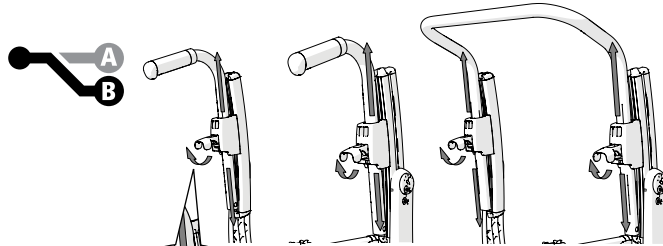

Back support mod. 2

Loosen the knob (A) and press the red plastic washer. Then as above.

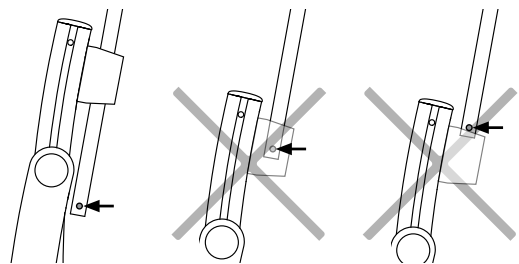
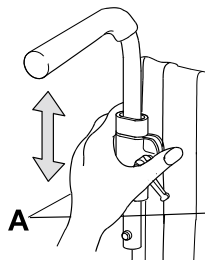

Cross drum brake (service brake)

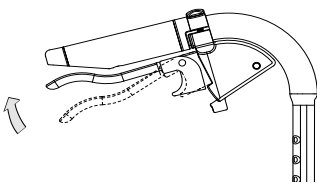

- Brake while in motion by pulling the brake lever upwards.

Cross drum brake (parking brake)

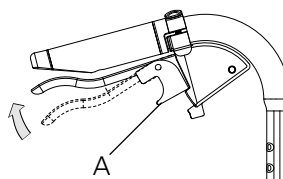

- Activate the parking brake by pulling the brake lever upwards and pressing in button A.
- Release by pulling the lever upwards.

User manual

Settings seat comfort

Seat comfort

Good seating comfort depends on the needs and possibilities available to each individual. The following general guidelines here show what to consider when settings are made.

Select a seat cushion with care. Aside from comfort, it has an impact on stability and thereby freedom of movement. Seat cushions also have different pressure distribution

qualities.

The back support setting is a combination of angles, height and shape. This is why the angle settings and height for the back support may need to be adjusted when the back support cover is being adjusted.

Back support cover

- Loosen all back straps, but make sure that the Velcro is still stuck together.
- Place the back support cover so that it covers the upper edge of the back rails and forms a crease between the seat and the back support allowing the user to properly sit in on the seat.

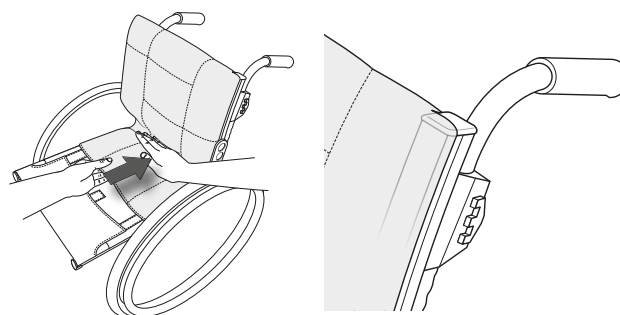

Seat cushion

- Make sure that the correct seat depth is set.
- Position the cushion as far back on the seat so that the rounded corners end up between the back rails.
- Measure a suitable seat cushion length and cut it according to supplied instructions.
- A more contoured seat cushion can be obtained by using a comfort wedge which is placed in the cushion cover's pocket under the seat cushion.

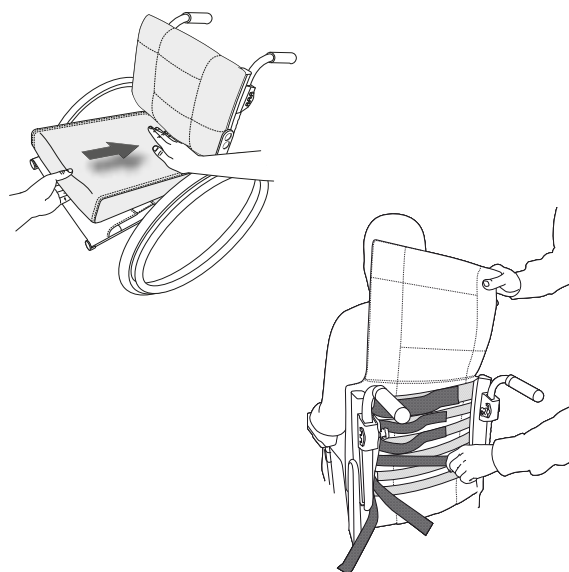

Back support upholstery

The back support upholstery is adjusted with the user sitting in the wheelchair.

- Make sure the user is sitting as far back in the seat as possible.
- Support the pelvis by tightening the strap found just below the lumbar region.
- Then adjust the upper strap to provide the user with upper body support and balance.
- The other straps are adjusted to provide space for the user's posterior and follow the back's natural curvature.

Back support angle

The back support angle may need to be adjusted when adjusting the shape of the back support upholstery. Contact your dealer or your Technical Aids Centre.



Tipping risk. Inactivated anti-tips will increase the risk of injury. Activate the anti-tips to avoid the risk of tipping.



Do not overtighten the upper straps as this can prevent the cross-brace from unfolding properly, i.e. the seat-frame tubes do not sit flush in the sideframes.

User manual

Settings seat comfort

Foot supports

Adjust the height until you are sure that your feet are supported and your thighs are resting on the cushion.

For outdoor use the foot supports should be raised 4-5 cm above the ground.

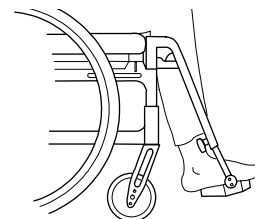

Adjusting the angle

Adjust the foot support angle, so the ankles are at 90°.

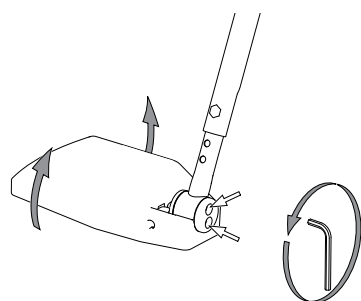

5 mm

Adjusting the height

Loosen the knob and pull out the screw. Set the height. Assemble the screw and knob and tighten firmly.

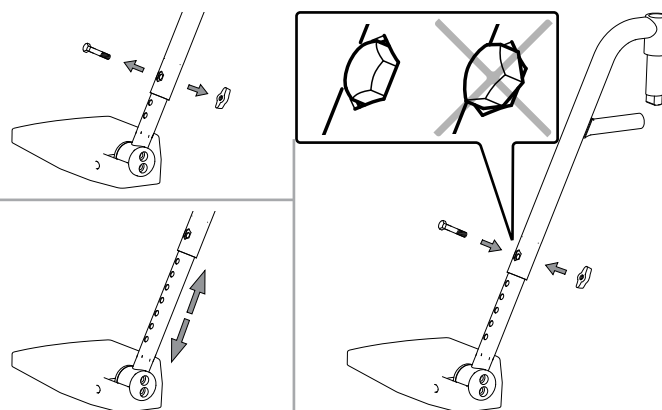

Changing the depth of the foot supports

Adjust the depth of the foot supports by switching the right and left foot support. Do not forget to adjust the angle.

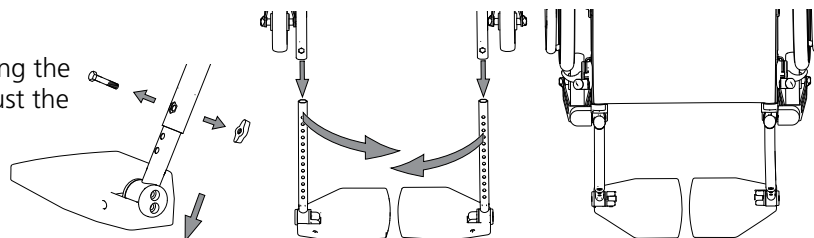

Calf/heel strap

- Adjust the length so that your insteps rest on the foot supports.

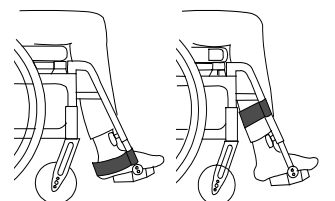

Arm support (adjusting)

- Loosen the screw on the inside of the arm support plate.
- Set the required height and tighten the screw.
- The high position of the arm supports, supports and relieves pressure on the back better than a lower position.

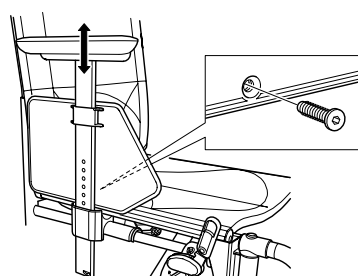

3 mm

User manual

Driving technique, maneuvering



Parking

Turn the castor wheels forwards and activate the brakes.

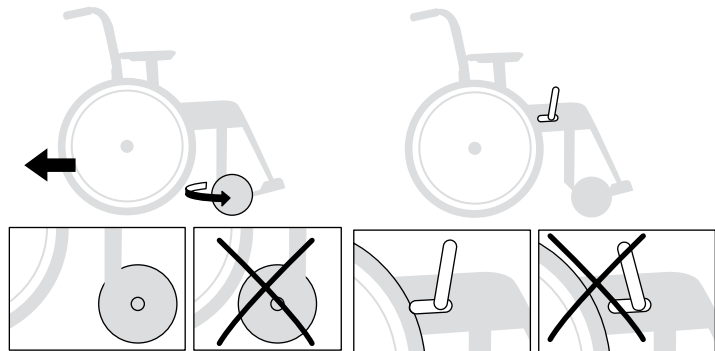

Transferring into/out of the wheelchair

Turn the castor wheels forwards, activate the brakes, flip up the foot supports and twist the leg supports to one side.

 Do not stand on the foot plates. Risk of injury.

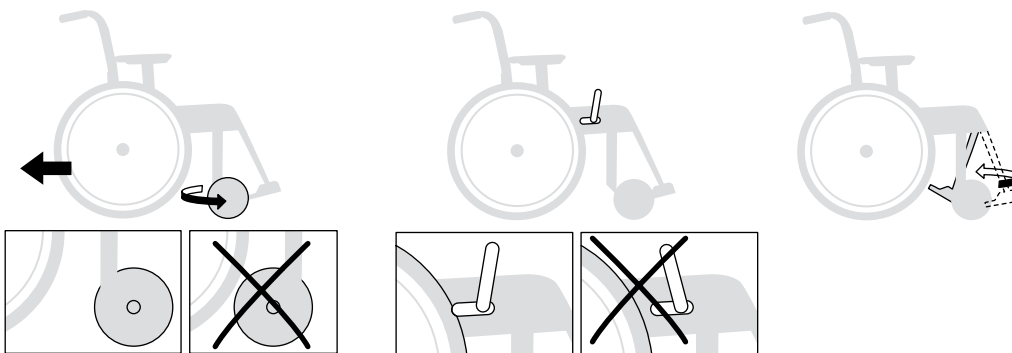

Sideways

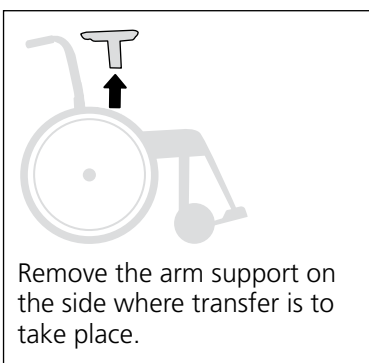

From the front

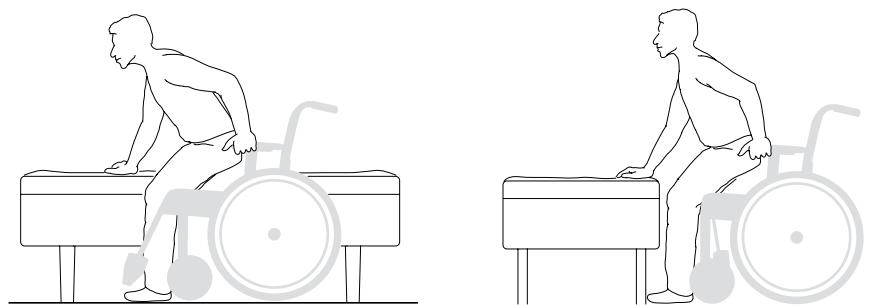

Lifting the wheelchair

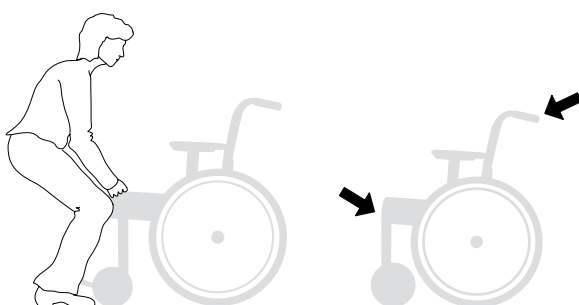

Lift the wheelchair by the push handles and the front upper part of the frame or by lockable leg supports. Remove or swing non-lockable leg supports (fixed, elevated, amputee) in under the seat.

Before lifting in the push handles, make sure the knobs/locking handles are properly tightened/locked and that the safety buttons have popped out below the brackets.

 Check that the lockable leg supports are locked before lifting. Risk of injury.

User manual

! The following figures show principles for propelling techniques and how to overcome obstacles like steps and curbs.



Tipping risk. Inactivated anti-tips will increase the risk of injury. Activate the anti-tips to avoid the risk of tipping.



User, up forwards

This technique is recommended only for experienced wheelchair users.

– Ensure that the anti-tips are deactivated.

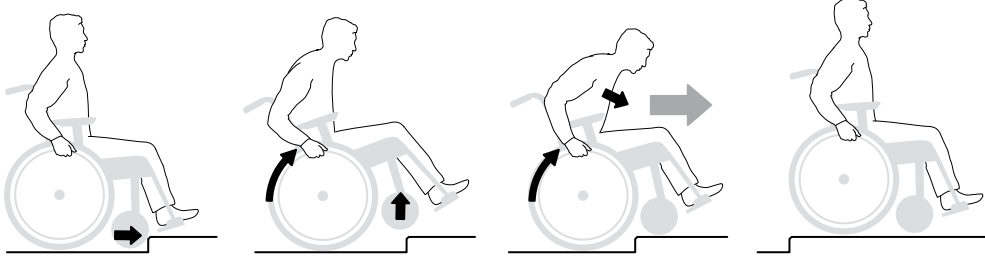

User, up backwards

This technique only works if there is a low kerb/threshold, relative to the installed height of the foot supports.

– Ensure that the anti-tips are deactivated.

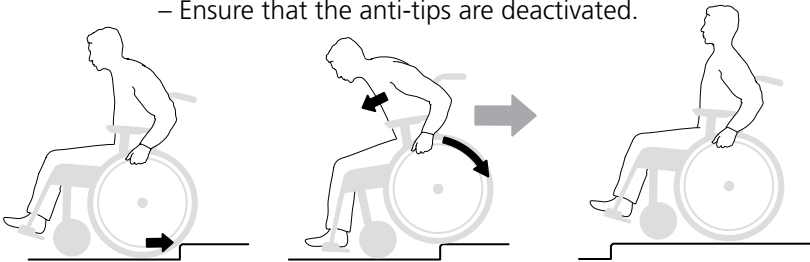

User, down forwards

This technique is recommended only for experienced wheelchair users.

– Ensure that the anti-tips are deactivated.

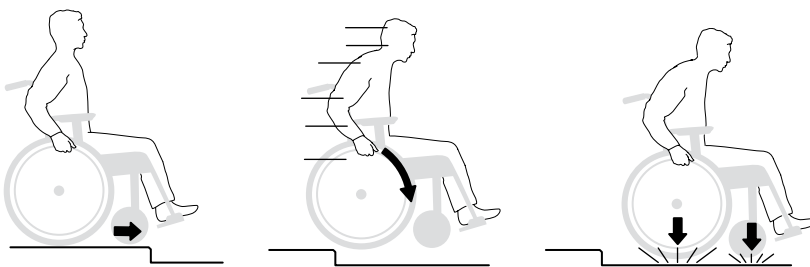

User, down backwards

This technique is recommended only for experienced wheelchair users.

– Ensure that the anti-tips are deactivated.

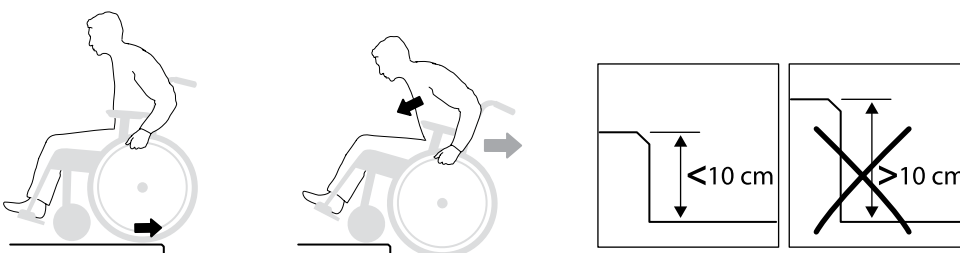

User manual



Care giver, up forwards

– Ensure that the anti-tips are deactivated.



Tipping risk. Inactivated anti-tips will increase the risk of injury. Activate the anti-tips to avoid the risk of tipping.

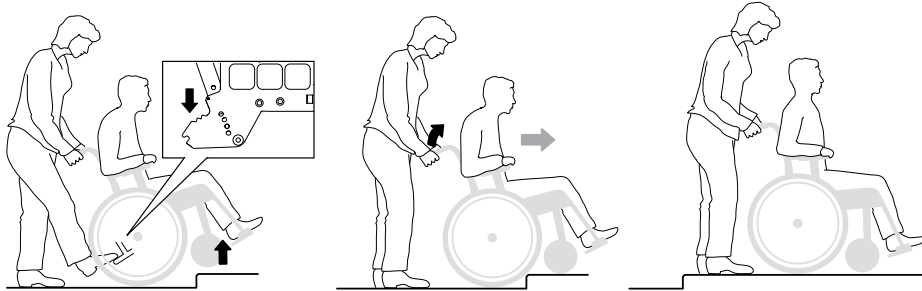

Care giver, up backwards

– Ensure that the anti-tips are deactivated.

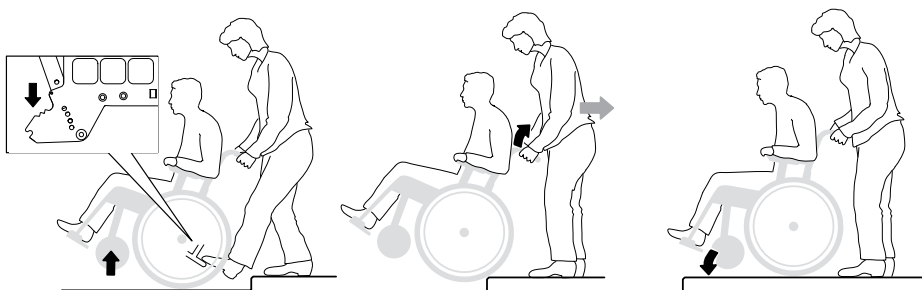

Care giver, down forwards

– Ensure that the anti-tips are deactivated.

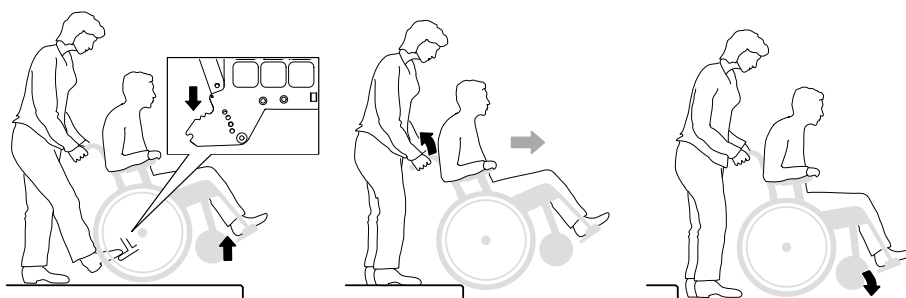

Care giver, down backwards

– Ensure that the anti-tips are deactivated.

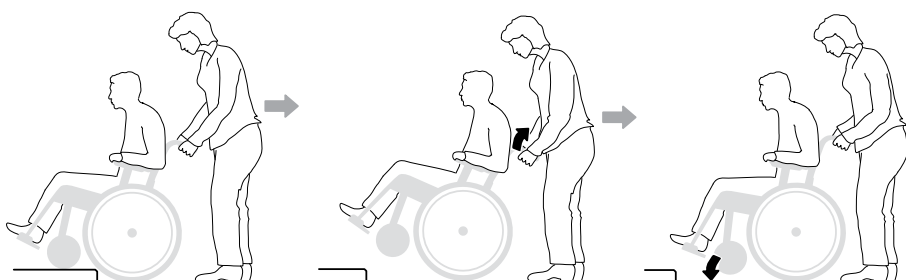

User manual



Stairs, up

– Ensure that the anti-tips are deactivated. Never use an escalator, even if a care giver is available. Ensure that height adjustable push handles are tightened.

We always recommend using two carers for this transfer. One who walks behind and holds on to the push handle and one who walks in front and holds on to the frame (or in the leg supports if these are lockable).



Tipping risk. Inactivated anti-tips will increase the risk of injury. Activate the anti-tips to avoid the risk of tipping.

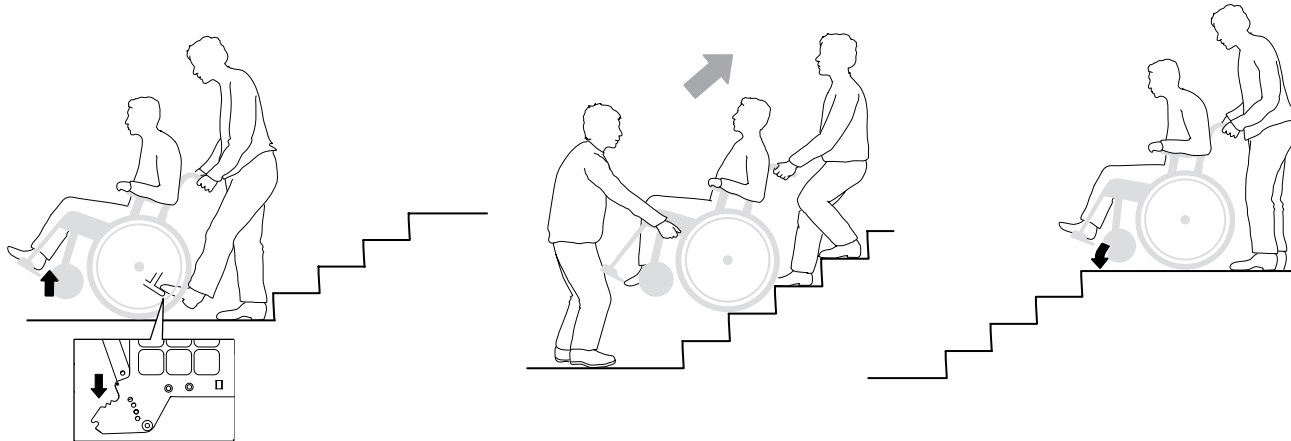

Stairs, down

– Ensure that the anti-tips are deactivated. Never use an escalator, even if a care giver is available. Ensure that height adjustable push handles are tightened.

We always recommend using two carers for this transfer. One who walks behind and holds on to the push handle and one who walks in front and holds on to the frame (or in the leg supports if these are lockable).

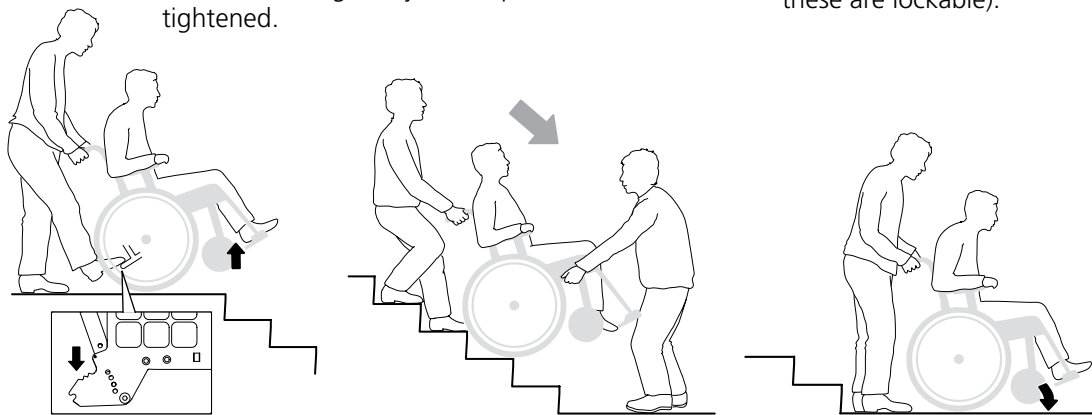

Driving uphill/downhill

Control your speed using the handrims, not the brakes!

Avoid turning round in the middle of a hill. Always drive as straight up/down as possible. If uncertain, ask for assistance.

Uphill

Lean forwards to correct your centre of balance.

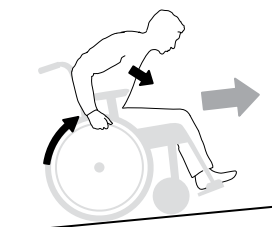

Downhill

Lean backwards to correct your centre of balance.

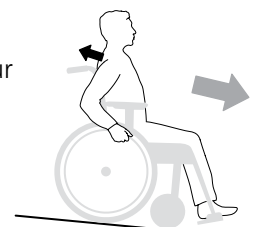

User manual

Maintenance

Rear wheels: Clean quick release axles as required.

Tyre pressure: Check the tyre pressure (once/month).

Castors: Clean castor wheel axles as required.

Chassis: Clean the chassis with non-abrasive detergent, pH value 5-9 or with 70 % disinfectant solution. Rinse and dry.

Upholstery: Wash, see labels on each item.

If necessary, lubricate moving parts/joints with cycle oil or similar.

In the event of problems, contact your dealer or Technical Aids Centre.

Fault-finding chart

The wheelchair is pulling diagonally	<ul style="list-style-type: none"> • Inflate the tyres • Check and adjust the angle of the front fork attachments • Check that the front fork attachments are set at the same height • The user's weight is not evenly distributed in the wheelchair • More strength being used on one side than the other when propelling the chair
The wheelchair feels "heavy" to propel	<ul style="list-style-type: none"> • Inflate the tyres • Rear wheel mountings are incorrectly fitted • Clean the castor axles from hair and dirt • Too much weight over the castors. Adjust the centre of balance
The wheelchair feels "heavy" to turn	<ul style="list-style-type: none"> • Inflate the tyres • Check that the front fork attachments are not too tight • Check and adjust the angle of the front fork attachments • Clean the castor axles from dirt • Too much weight over the castors. Adjust the centre of balance
Brakes not effective	<ul style="list-style-type: none"> • Inflate the tyres • Adjust the distance between brake and tyre
Rear wheels "loose"	<ul style="list-style-type: none"> • Adjust the length of the axle shaft
Rear wheels hard to remove/re-place	<ul style="list-style-type: none"> • Clean and lubricate quick release with cycle oil or similar • Adjust the length of the axle shaft
The castor wheels "wobble"	<ul style="list-style-type: none"> • The front forks are not tight enough • Check and adjust the height and angle of the front fork attachments • Too much weight over the castors. Adjust the centre of balance
The wheelchair is hard to fold/unfold	<ul style="list-style-type: none"> • The upholstery is too tight • Clean and lubricate the cross-brace under the seat
The wheelchair feels "awkward"	<ul style="list-style-type: none"> • Inflate the tyres • Check that screws, nuts and bolts are properly tightened

5. Settings

Cross 5	Cross 5 XL
---------	------------

Seat angle

The **seat angle** is dependent on the difference between the front and the rear seat heights.

If the seat angle is changed:

- Adjust the angle of the front fork attachment.
- Check the back support angle.

 **Tipping risk.** Inactivated anti-tips will increase the risk of injury. Activate the anti-tips to avoid the risk of tipping.

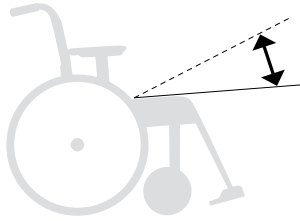

●	●
---	---

Seat depth

The **seat depth** can be adjusted by lifting the front seat upholstery and sliding it backwards or forwards.

With Cross back support 3A triangular, the seat depth can be further adjusted by means of the lumbar angle (see the section "*Adjusting seat depth using lumbar angle, triangular back*").

 **Tipping risk.** Inactivated anti-tips will increase the risk of injury. Activate the anti-tips to avoid the risk of tipping.

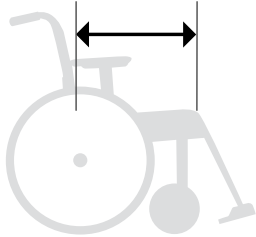

●	●
---	---

Seat comfort

After adjusting seat height, seat angle, seat depth and back support angle, the back support upholstery must be adjusted to optimize the seat comfort. See the "*Settings seat comfort*" section in the User manual.

●	●
---	---

6. Settings back support 3A

Adjusting back support angle

Cross 5	Cross 5 XL
●	●

1. Loosen the nut.
2. Adjust the back support angle. Use the position markings to obtain the same back support angle on the right and left sides respectively.

3. Tighten the nut.

 Tipping risk. Inactivated anti-tips will increase the risk of injury. Activate the anti-tips to avoid the risk of tipping.

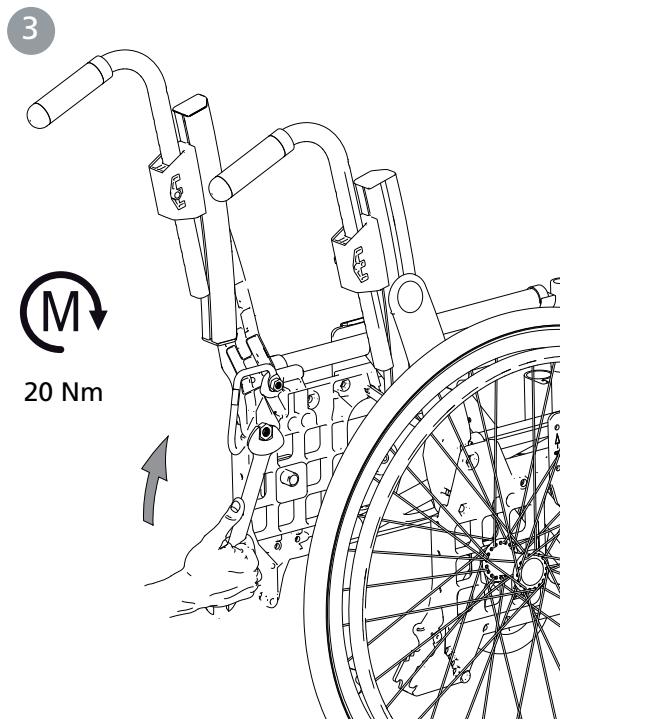
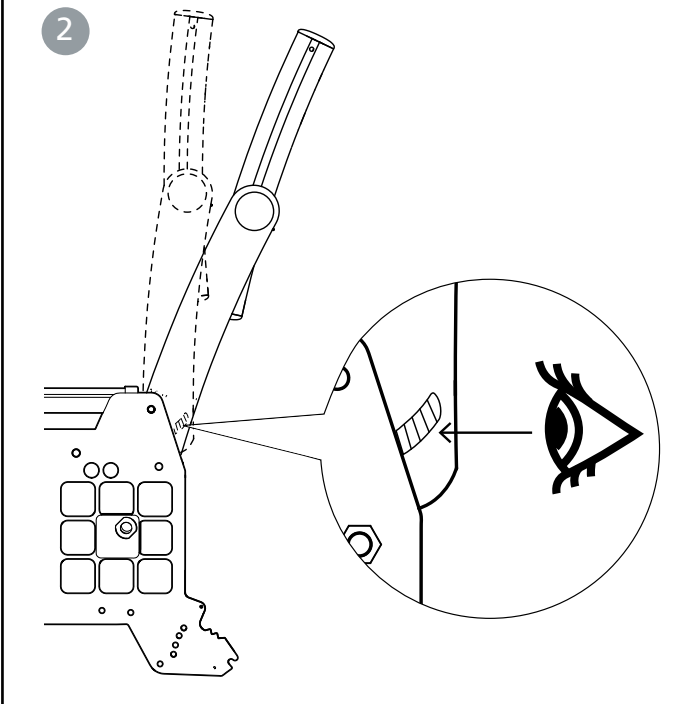
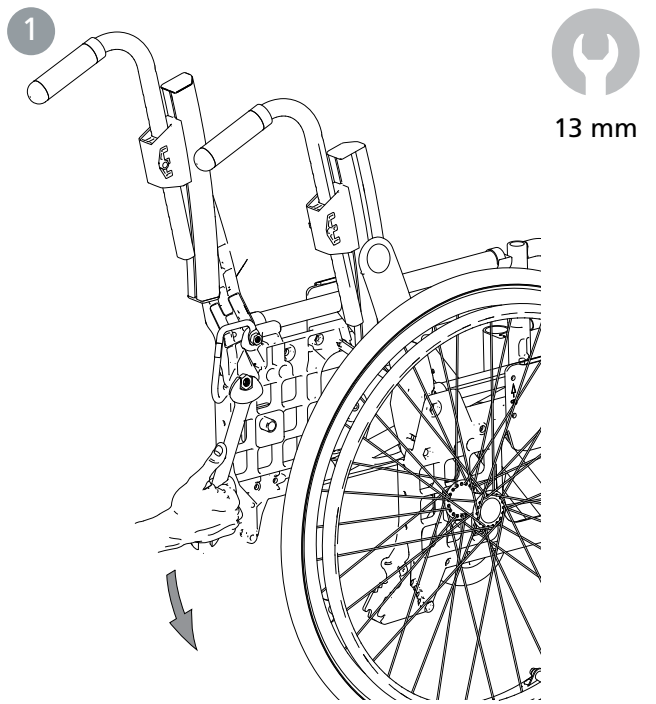

6. Settings back support 3A

Cross 5

Cross 5 XL

Adjusting the back support height and lumbar angle (one eccentric shaft)

1. Loosen the locking screws (A) max. 1 turn.
2. Adjust the back support height using the graduation and the marking on the lower back rod. Tighten the locking screws max. 1/2 turn.
3. Place the Allen key in the eccentric shaft's locking screw and loosen it 1/2 turn. Move the Allen key to the eccentric shaft's key handle and set the required lumbar angle.
4. Tighten the locking screws with 6 Nm.



Tipping risk. Inactivated anti-tips will increase the risk of injury. Activate the anti-tips to avoid the risk of tipping.

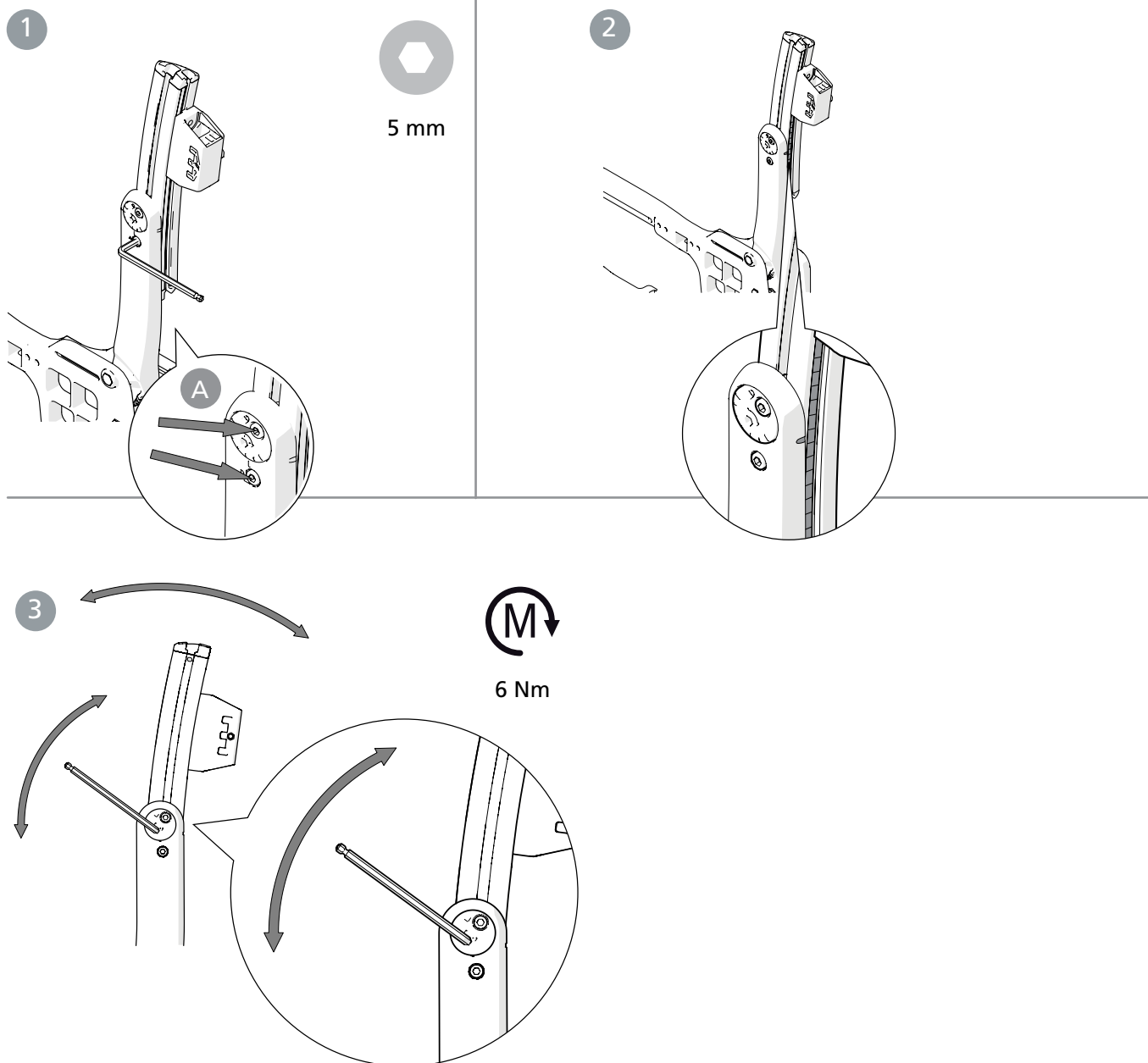

6. Settings back support 3A

Adjusting seat depth using lumbar angle (one eccentric shaft)

An extended seat depth is achieved by opening the back support angle (hip) and then the lumbar angle.

1. Adjust the back support angle (see also *illustration 1-3 on page 32*).

2. Adjust the lumbar angle to the required back support angle using the eccentric shaft as in *point 4-5 on page 34*.

3. If necessary fit seat extender (accessory)..



Tipping risk. Inactivated anti-tips will increase the risk of injury. Activate the anti-tips to avoid the risk of tipping.

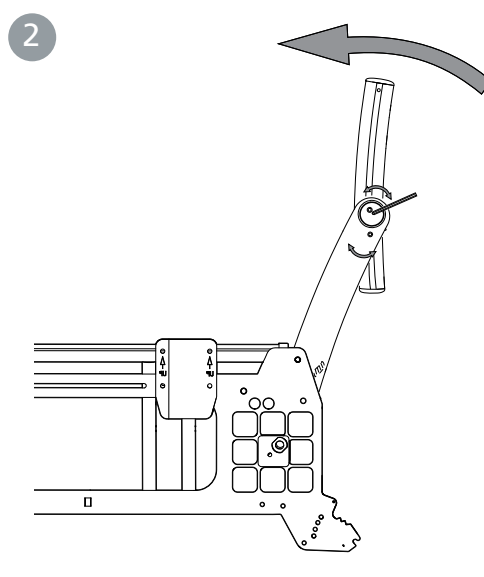
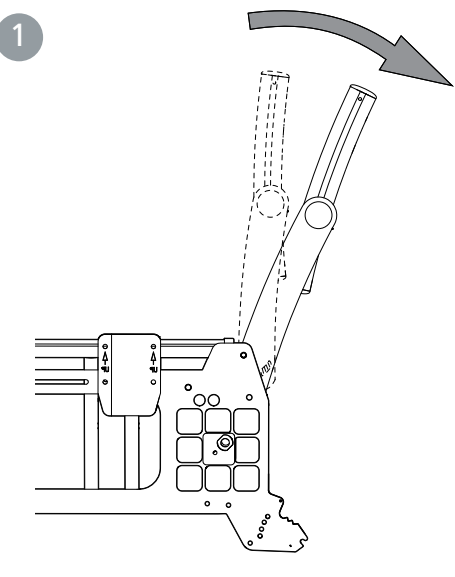

5 mm

Fitting seat extender

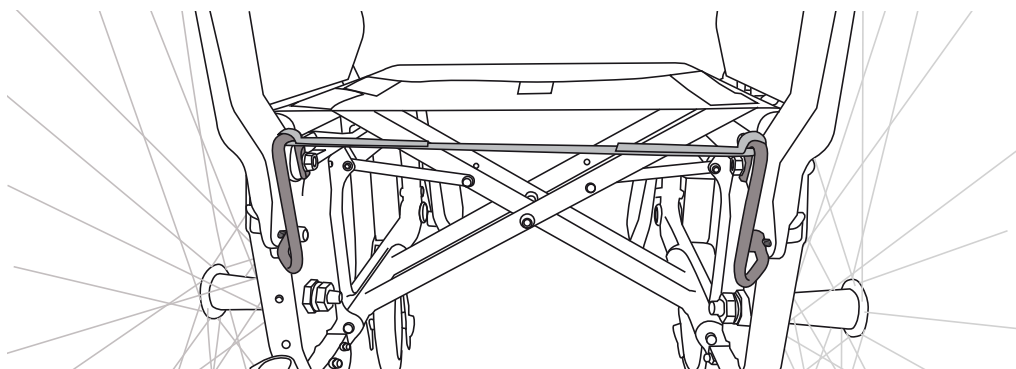
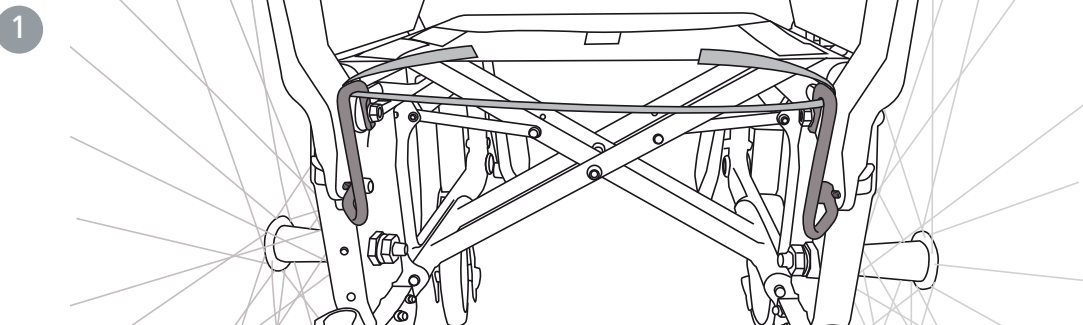

Cross 5	Cross 5 XL
●	●
●	●

6. Settings back support 3A

Cross 5

Cross 5 XL

Adjusting the back support height and lumbar angle (two eccentric shafts)

1. Loosen the locking screws (A) max. 1 turn.
2. Adjust the back support height using the graduation and the marking on the lower back rod. Tighten the locking screws max. 1/2 turn.
3. Place the Allen key in the selected (upper recommend-ed) eccentric shaft's locking screw and loosen it 1/2 turn. Move the Allen key to the eccentric shaft's key handle and set the required lumbar angle.
4. Tighten the locking screws with 6 Nm.



We recommend that you start adjusting the lumbar angle with the upper eccentric shaft. If a larger angle is required, adjust the lower eccentric shaft as well.



Tipping risk. Inactivated anti-tips will increase the risk of injury. Activate the anti-tips to avoid the risk of tipping.

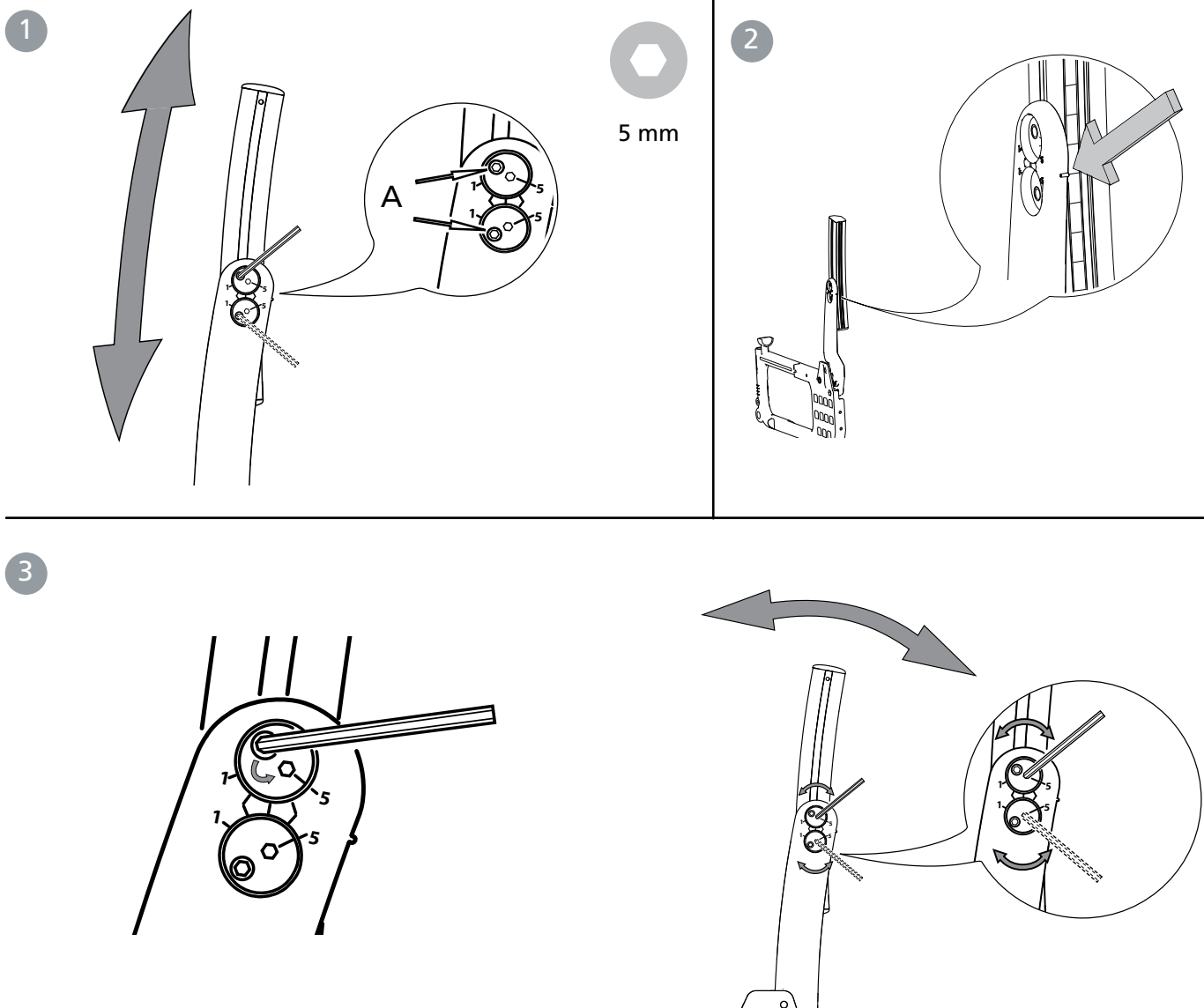

6. Settings back support 3A

Cross 5

Cross 5 XL

Adjusting seat depth using lumbar angle (two eccentric shafts)

An extended seat depth is achieved by opening the back support angle (hip) and then the lumbar angle.

1. Adjust the back support angle (see also *illustration 1-3 on page 32*).
2. Adjust the lumbar angle to the required back support angle using the eccentric shafts as in *point 4-5 on page 34*.

3. If necessary fit seat extender (accessory)..



Tipping risk. Inactivated anti-tips will increase the risk of injury. Activate the anti-tips to avoid the risk of tipping.

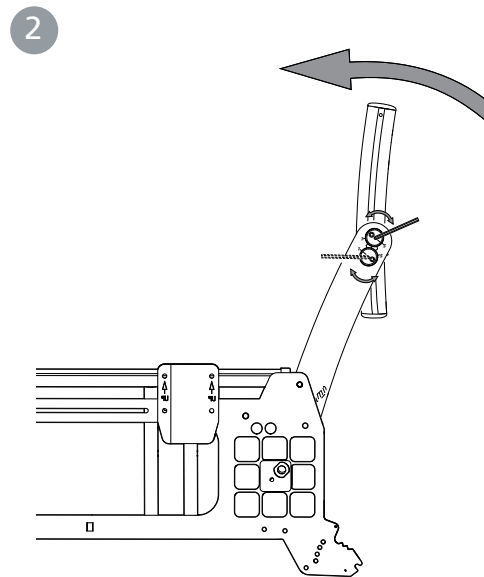
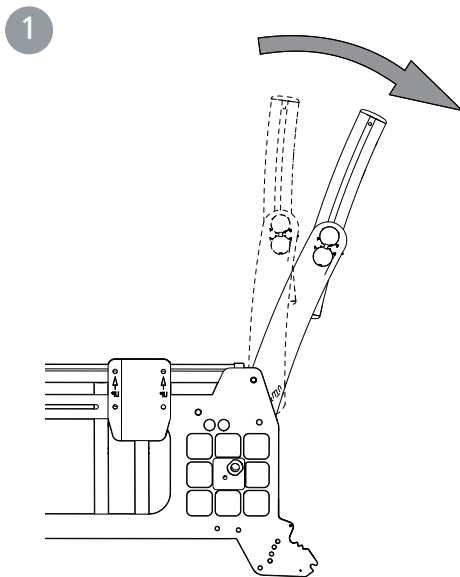

5 mm

7. Settings back support mod. 2

Setting back support height

The back support height is continuously settable (See "The chairs possibilities").

Loosen the screws (A) 2-3 turns to set the height of the back support. Ensure that both sides are at the same height by checking against the ruler (B) on the back of the back tube. Tighten the screws securely.

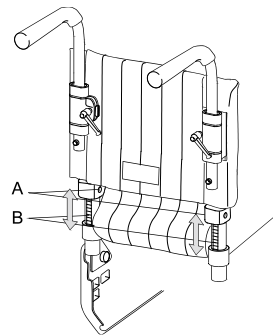

5 mm



Tipping risk. Inactivated anti-tips will increase the risk of injury. Activate the anti-tips to avoid the risk of tipping.

Adjusting back support angle

The back support angle is infinitely variable (See "The chairs possibilities"). The angle is adjusted using the nut on the inside of the rear wheel attachments.

- Loosen the nut on one of the back tubes, set the desired angle and tighten the nut firmly again.
- Repeat the procedure on the other side.

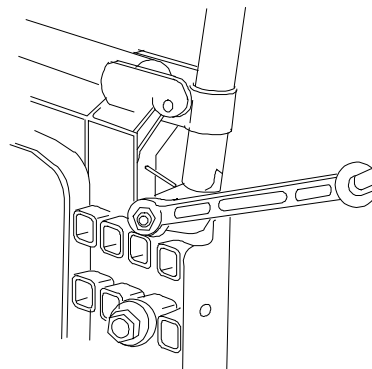

13 mm



Check that the angle is the same on both sides by comparing the distance between the back tube and the arm support plate.



Tipping risk. Inactivated anti-tips will increase the risk of injury. Activate the anti-tips to avoid the risk of tipping.

Adjusting back support upholstery

The contour of the back support upholstery is individually adjustable by using the five Velcro straps and the back support cover.

- Allow the cover plenty of room between seat and back support, so that it is possible to "sit in" against the back support.
- Loosen all the straps and ensure that the user is sitting as far back in the seat as possible.
- Tighten the straps in such a way that they follow the contours of the user's back and give plenty of support to the lumbar region.

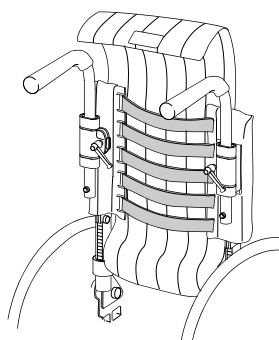

Do not overtighten the upper straps as this can prevent the cross-brace from unfolding properly, i.e. the seat-frame tubes do not sit flush in the sideframes.



Tipping risk. Inactivated anti-tips will increase the risk of injury. Activate the anti-tips to avoid the risk of tipping.

Cross 5

Cross 5 XL

8. Settings back support mod. 2B

Setting back support height

The back support height is settable (See "The chairs possibilities").
Loosen the screws to set the height of the back support. Tighten the screws.

 **Tipping risk.** Inactivated anti-tips will increase the risk of injury. Activate the anti-tips to avoid the risk of tipping.

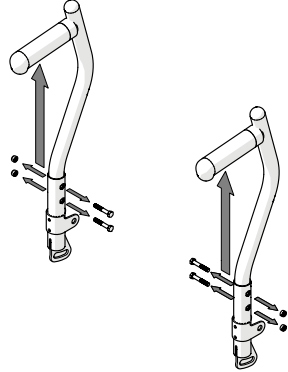

Adjusting back support angle

The back support angle is infinitely variable (See "The chairs possibilities"). The angle is adjusted using the nut on the inside of the rear wheel attachments.
- Loosen the nut on one of the back tubes, set the desired angle and tighten the nut firmly again.
- Repeat the procedure on the other side.

 Check that the angle is the same on both sides by comparing the distance between the back tube and the arm support plate.

 **Tipping risk.** Inactivated anti-tips will increase the risk of injury. Activate the anti-tips to avoid the risk of tipping.

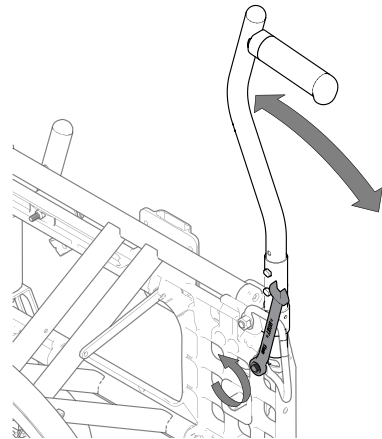

Adjusting back support upholstery

The contour of the back support upholstery is individually adjustable by using the five Velcro straps and the back support cover.
- Allow the cover plenty of room between seat and back support, so that it is possible to "sit in" against the back support.
- Loosen all the straps and ensure that the user is sitting as far back in the seat as possible.
- Tighten the straps in such a way that they follow the contours of the user's back and give plenty of support to the lumbar region.

 Do not overtighten the upper straps as this can prevent the cross-brace from unfolding properly, i.e. the seat-frame tubes do not sit flush in the sideframes.

 **Tipping risk.** Inactivated anti-tips will increase the risk of injury. Activate the anti-tips to avoid the risk of tipping.

9. Readjustments

Cross 5

Cross 5 XL

Brake, adjustment

The brakes are infinitely settable.

1. Loosen the screw a couple of turns.
2. Set the brake in correct position.
3. The brake block should be 15-20 mm from the tyre when the brake is not applied.

4. Ensure that the brake is straight in the groove and tighten the screw. Test the brakes.
5. Ensure the nut locks on the inside.



The braking effect is dependent on the air pressure in the tyres. The brakes are parking brakes and should not be applied during use.

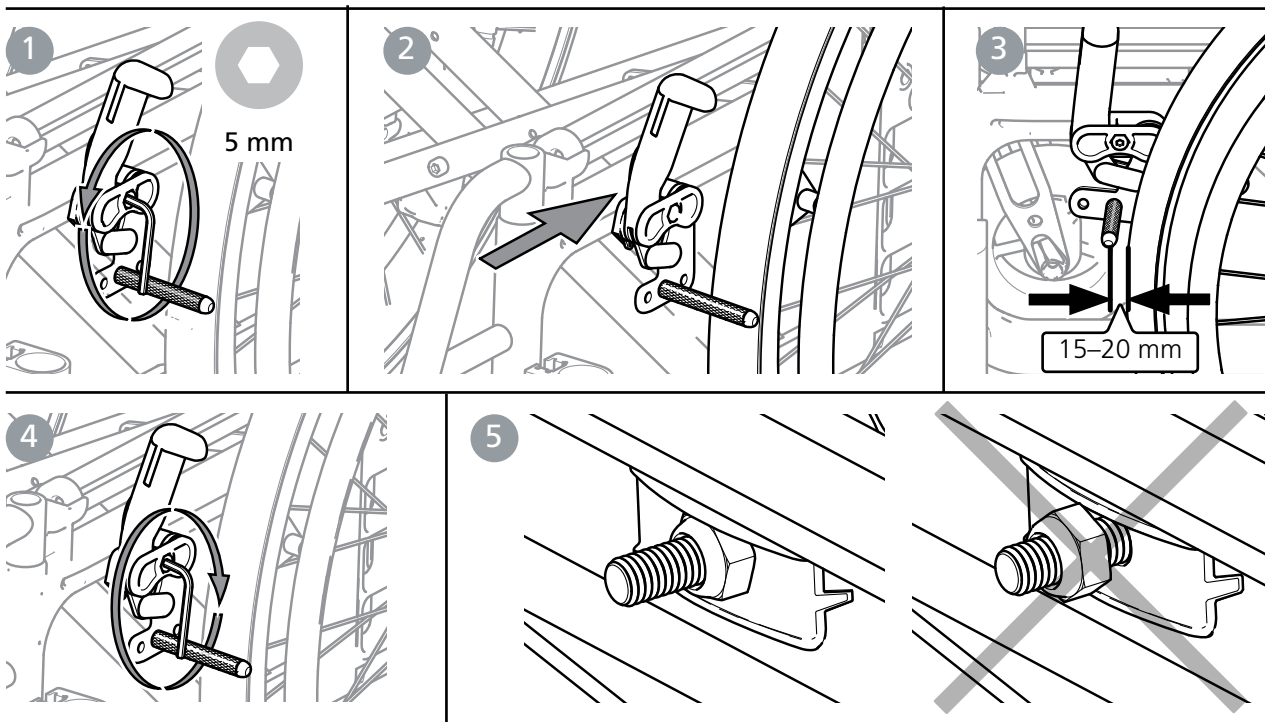

If the rear wheel is positioned in one of the forward settings it is possible for a leg support, when swung to the side, to unlock an applied brake. To avoid this the brake handle should be adjusted so that you attain a "neutral" position. In this way the brake will unlock first when the handle is pushed close to the rear wheel.

1. Loosen the screw on the inside of the brake handle.
2. Remove the oval plate, turn it 180° (the pin on the plate's inside must sit in the upper hole).
3. Tighten it again.

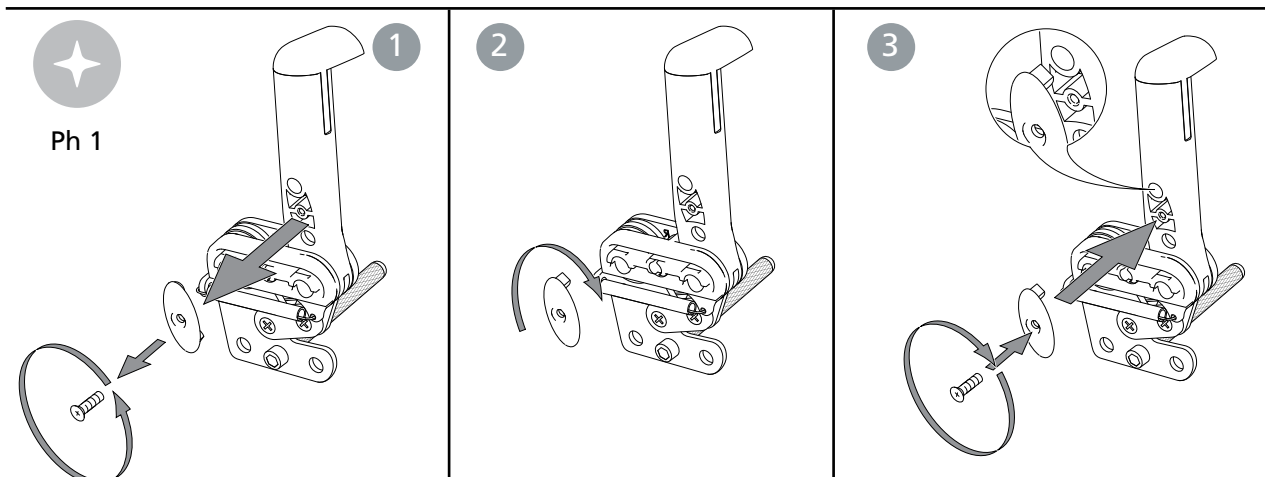

9. Readjustments

Cross 5
Cross 5 XL

Adjusting the brake block

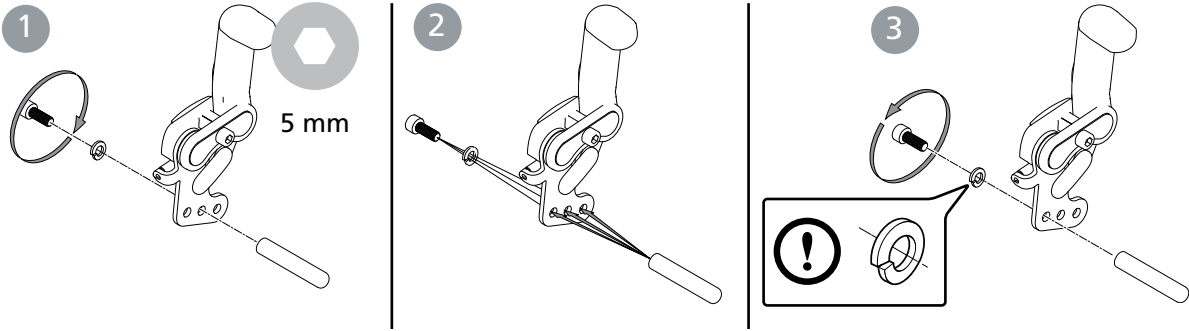

Leg support, infinitely angle adjustable

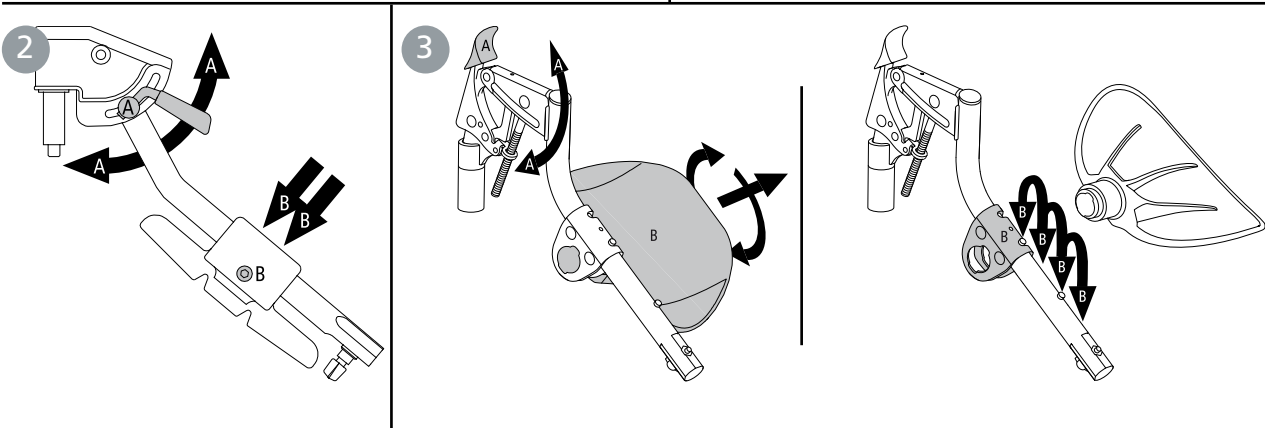
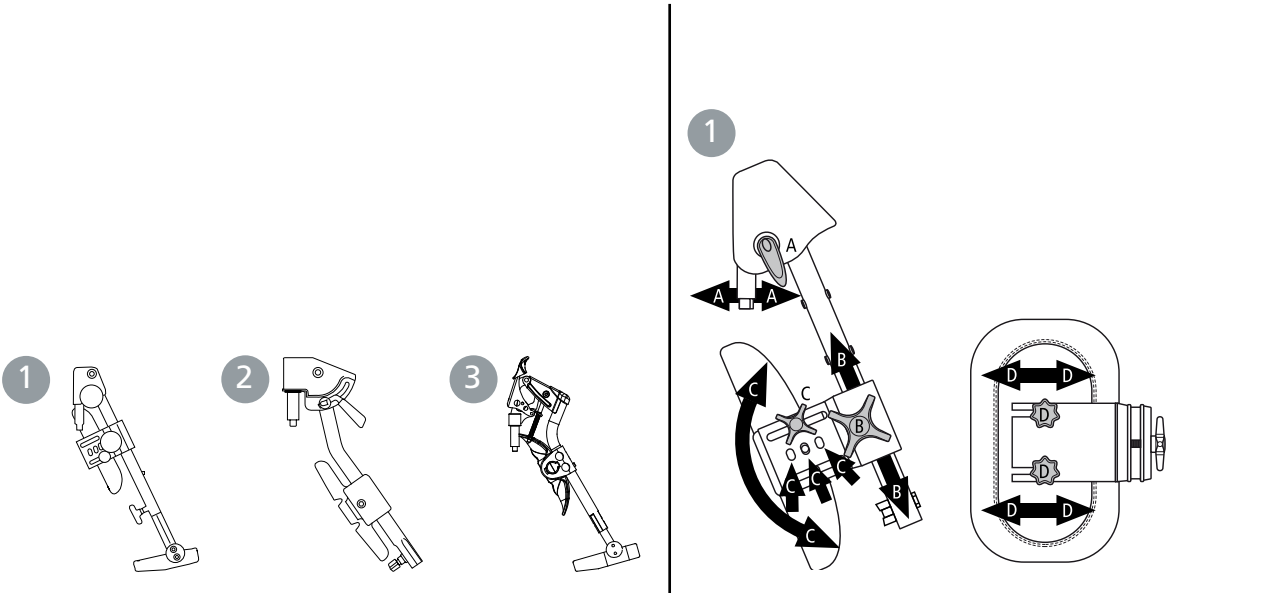

9. Readjustments

Cross 5
Cross 5 XL

Amputee leg support

Never sit on the amputee leg support.

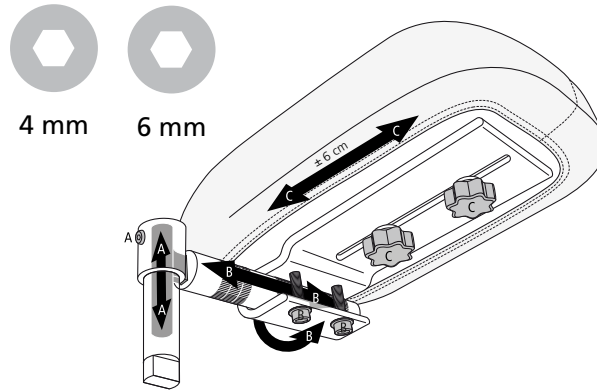

Anti-tips

The anti-tips are settable in height and angle and adjustable in length.

 Tipping risk. Inactivated anti-tips will increase the risk of injury. Activate the anti-tips to avoid the risk of tipping.

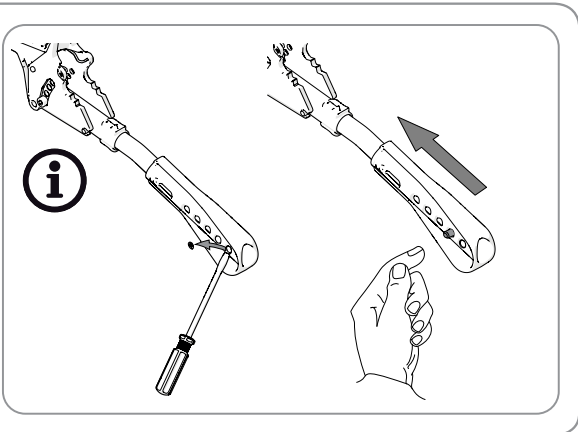
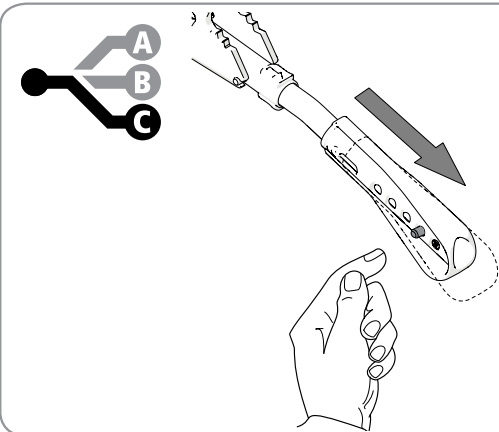
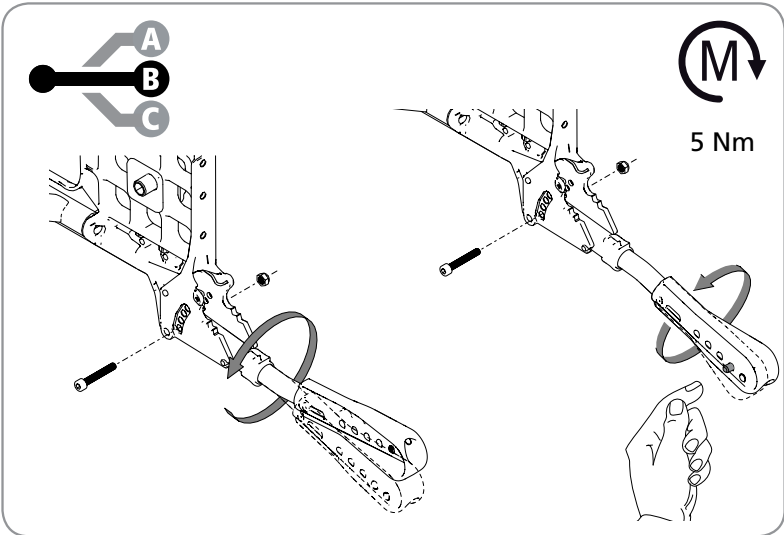
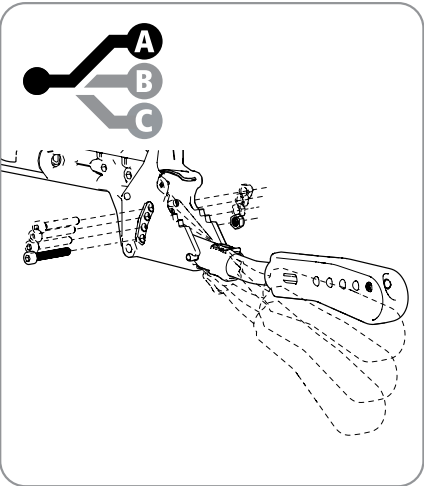
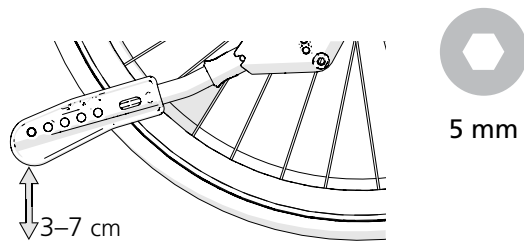

9. Readjustments

Changing the camber angle

The camber angle can be changed by changing the washers that are mounted between the hub sleeve and the nut. See section "Adjusting rear seat height by changing rear wheel position or rear wheel size".

 When attaching the rear wheels, make sure that the quick-release button fully returns. Test by pulling the wheel. Risk of injury.

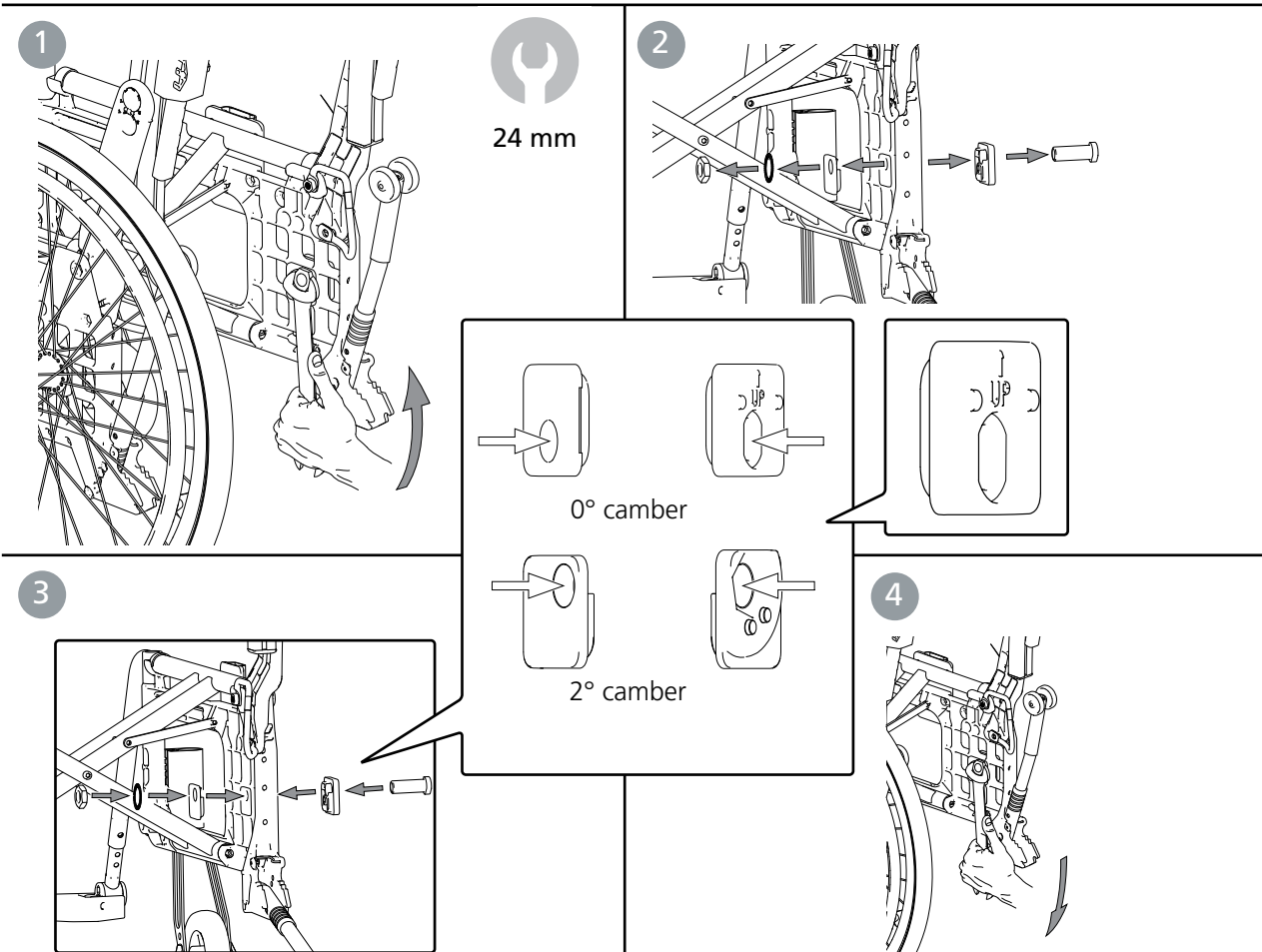

Adjusting the centre of balance

The centre of balance can be adjusted by changing the position of the rear wheels.
- Move the axle shaft/rear wheels forwards/backwards.



24 mm

When the position of the rear wheels is moved forwards the wheelchair becomes more manoeuvrable, but the tendency to tip backwards increases. See section "Adjusting rear seat height by changing rear wheel position or rear wheel size".
The brakes must also be adjusted, see section "Brake, adjustment".

 The centre of balance is also altered when the seat and/or back support angle is adjusted.

 Tipping risk. Inactivated anti-tips will increase the risk of injury. Activate the anti-tips to avoid the risk of tipping.

 When attaching the rear wheels, make sure that the quick-release button fully returns. Test by pulling the wheel. Risk of injury.

9. Readjustments

Cross 5
Cross 5 XL

Handrims

The material of the handrims and the distance between the rear wheels and handrims affect the user's ability to grip.



Fingers can be injured if they get between the spokes. Spoke protection is available as a means to prevent injury.

Adjusting the distance of the handrim

Aluminium, stainless, plastic-coated and cellular rubber handrims for 24", 22" and 20" rear wheel. The distance between the wheel and the handrim can be adjusted by moving or exchanging the two spacers.

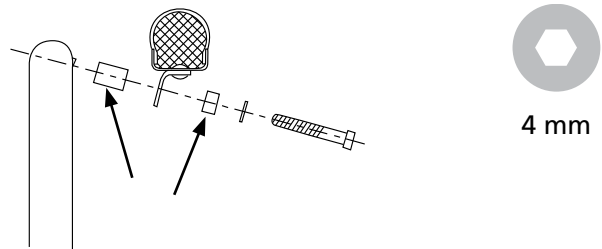

Drive wheels with quick-release axle

The distance between the hub sleeve and the locking balls can be adjusted by adjusting the nut on the outside of the hub. The distance between the hub sleeve and the locking balls should be 0.2 to 1.2 mm.



When attaching the rear wheels, make sure that the quick-release button fully returns. Test by pulling the wheel. Risk of injury.

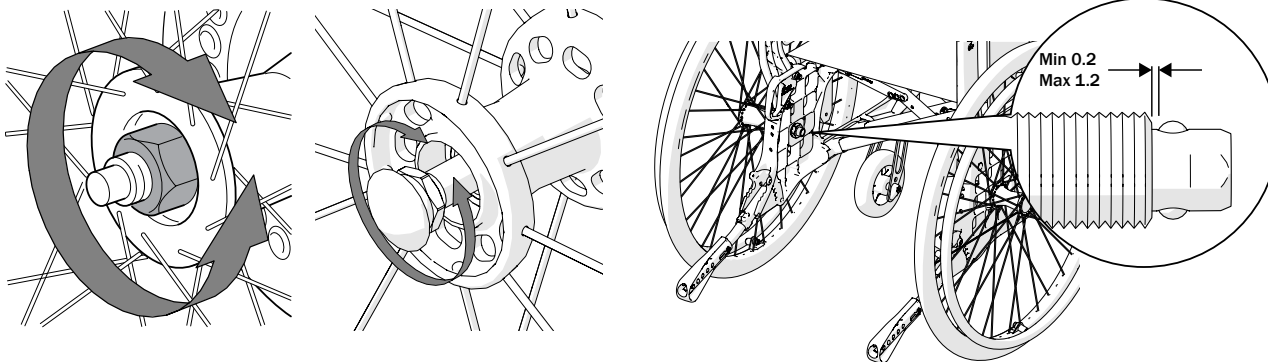

10. Accessories - adjusting, handling

Assembly instructions are always provided with accessories when they are delivered from Etac. Instructions are also available on our website www.etac.com.

Cross 5

Cross 5 XL

Seat cushion and comfort wedge

The cushion is cut to the required depth at the front or back edge. When measuring the length, ensure that the cushion is properly positioned between the back tubes with the rounded corners to the rear.

The cushion is a standard model and is not suitable for users with sitting sores.

A comfort wedge is a useful accessory for the seat cushion. It evens out the front edge of the seat, giving even greater seat comfort. Place the comfort wedge in the cushion-cover's inside pocket, under the cushion. The arrow on the comfort wedge should be on the top-side pointing forwards.

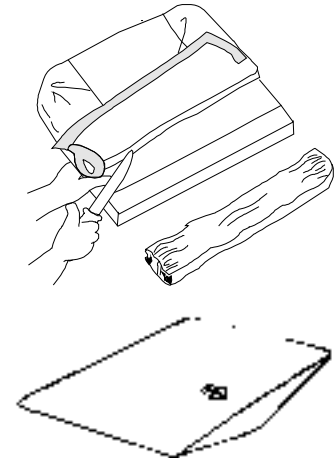

Arm support, detachable, height adjustable

The arm support attachment can be fitted in 2 different heights. In position 1 the height of the arm support is settable between 18 and 26 cm, and in position 2 (standard) between 24 and 31 cm, with 1 cm intervals.

Never use the arm supports to lift the wheelchair.



10 mm 5 mm

The lock lug is used both to set the height of the arm support and secure the side guard:

- Loosen the screw that fastens the lock lug.
- Slide the guard up or down to the desired height.
- Refasten the lug on the side guard.

If necessary the right arm support can be fitted on the left side and vice versa.



3 mm

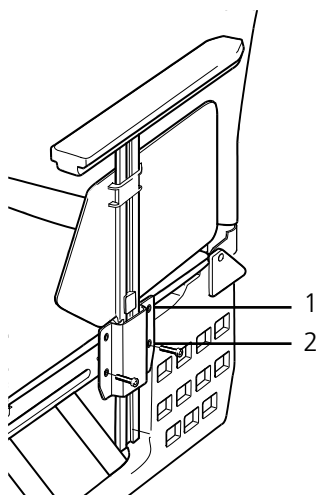

With 24" low pressure or solid tyres in pos. C1, the arm support's sideguard does not cover the front edge of the rear wheel.

10. Accessories - adjusting, handling

Arm support, flip-up, height adjustable

The flip-up arm support comes in two varieties, height adjustable and fixed. It is mounted onto the wheelchair's frame and can be flipped upwards/backwards by pressing the red lever (A) inwards.

Mount the arm support according to the assembly instructions supplied.

! For anti-tip limitations, refer to the information in the Accessory section.

The arm support height is settable between 22 and 30 cm with 1 cm intervals.

- Push the red lever to one side and loosen the screws that fix the arm support bracket to the frame.
- Slide the arm support up or down to the desired height.
- Tighten the screws again.

Never use the arm supports to lift the wheelchair.

! These arm supports cannot be combined with cane holder or with 24" 22" or 20" rear wheels in position C.

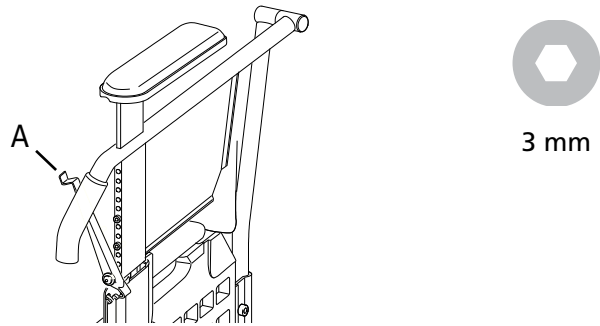

Positioning belt

The positioning belt is in two parts, is adjustable in length and has a snap-lock. It is mounted in the holes just in front of the back support joint, above the wheel mounts.

Assembly instructions are supplied with the belt. The belt is to be used only for positioning in the wheelchair. It must not be used as a substitute for a car safety belt.

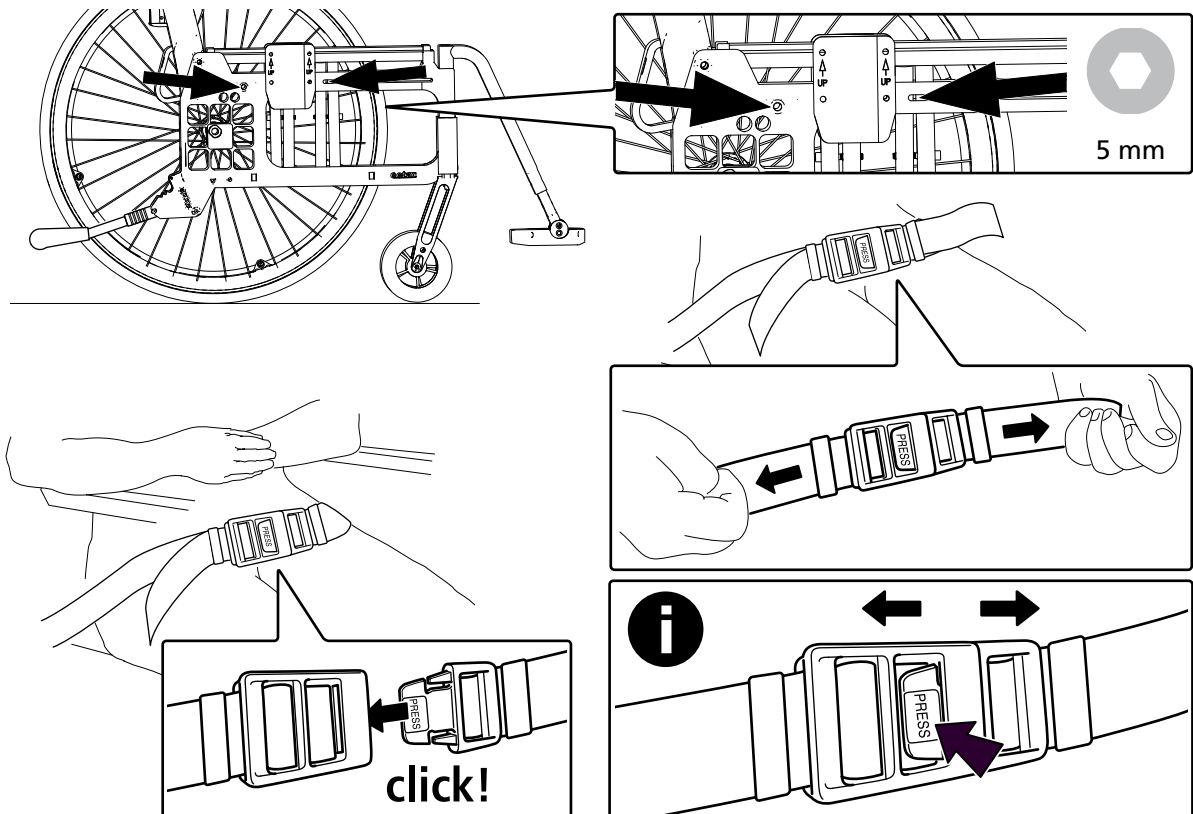



10. Accessories - adjusting, handling

Cross 5
Cross 5 XL

Head support

The head support is mounted onto the bow handle (accessory) or onto a separate head support attachment. The head support is adjustable in height, depth and angle, and is detachable.

 Before the head support is adjusted, ensure that the user has a good, secure sitting posture.

 The center of balance might be altered when the user leans against the head support.

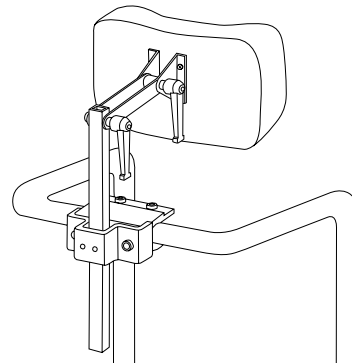

Head support attachment

The head support attachment is used to fit the head support.

 Do not lift the wheelchair by the head support mount. Risk of injury.

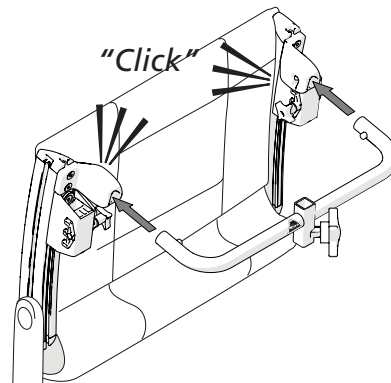

Cross brace

The cross bar is used when the back chassis needs to be reinforced.

 Do not lift the wheelchair by the crossbar. Risk of injury.

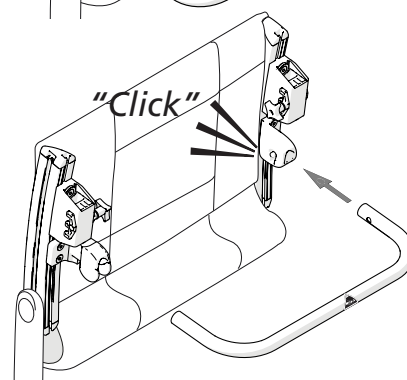
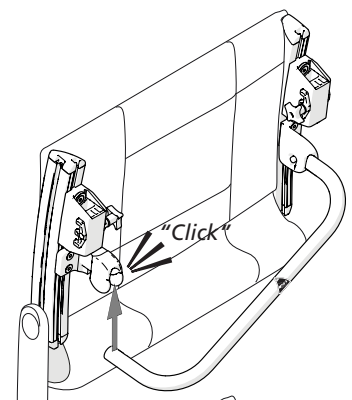

10. Accessories - adjusting, handling

Cross 5	Cross 5 XL
●	●

Attachment for chest harness

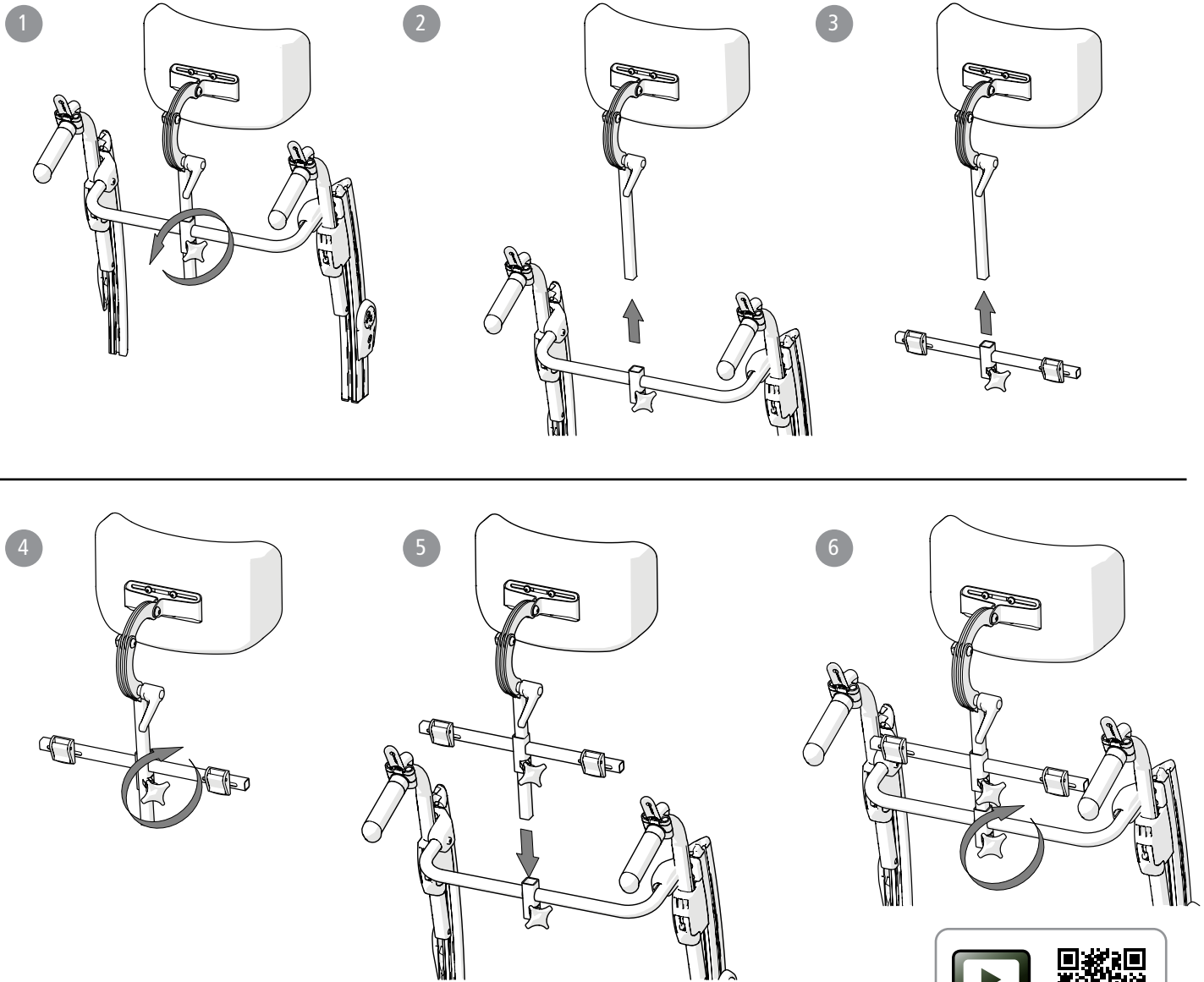

Attachment points for the chest harness

 Anterior trunk support shall only be used in combination with a positioning belt.

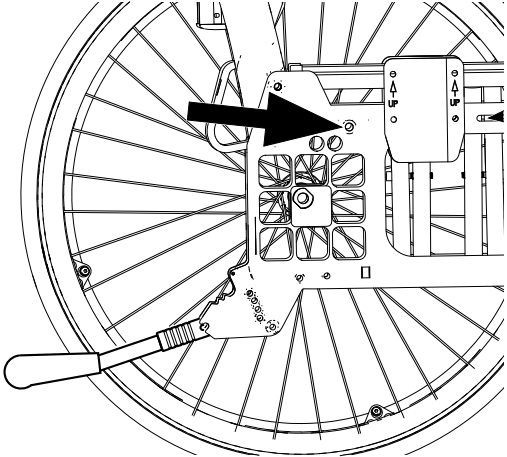
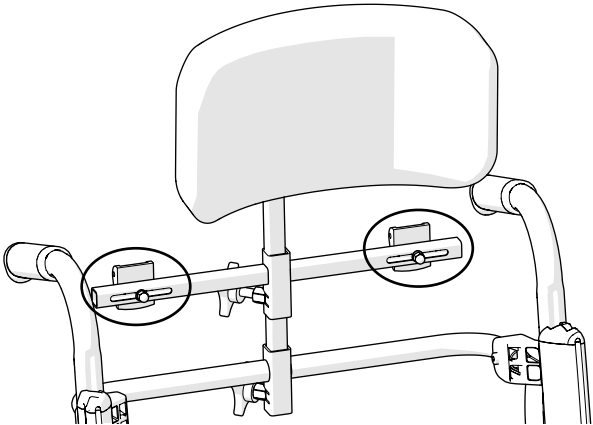

11. Technical data

	Type of chair	Item no Cross 5	Total width	Seat depth from back support tube**	Weight with rear wheel	Max user weight
Cross 5	35 cm short	13123001	56,0 cm	36-42 cm	15,0 kg	135 kg
	35 cm long	13123002	56,0	42-48	15,2 kg	135 kg
	37,5 cm short	13123003	58,5	36-42	15,1 kg	135 kg
	37,5 cm long	13123004	58,5	42-48	15,3 kg	135 kg
	40 cm short	13123005	61,0	36-42	15,2 kg	135 kg
	40 cm long	13123006	61,0	42-48	15,4 kg	135 kg
	42,5 cm short	13123007	63,5	36-42	15,3 kg	135 kg
	42,5 cm long	13123008	63,5	42-48	15,5 kg	135 kg
	45 cm short	13123009	66,0	36-42	15,5 kg	135 kg
	45 cm long	13123010	66,0	42-48	15,7 kg	135 kg
	47,5 cm short	13123011	68,5	36-42	15,6 kg	135 kg
	47,5 cm long	13123012	68,5	42-48	15,8 kg	135 kg
	50 cm short	13123013	71,0	36-42	15,7 kg	135 kg
	50 cm long	13123014	71,0	42-48	15,9 kg	135 kg

Cross 5 XL	47,5 cm short	13123111	68,5 cm	36-42 cm	15,9 kg	160 kg
	47,5 cm long	13123112	68,5	42-48	16,1 kg	160 kg
	50 cm short	13123113	71,0	36-42	16,0 kg	160 kg
	50 cm long	13123114	71,0	42-48	16,2 kg	160 kg
	52,5 cm short	13123115	73,5	36-42	16,1 kg	160 kg
	52,5 cm long	13123116	73,5	42-48	16,3 kg	160 kg
	55 cm short	13123117	76,0	36-42	16,3 kg	160 kg
	55 cm long	13123118	76,0	42-48	16,5 kg	160 kg
	57,5 cm short	13123119	78,5	36-42	16,4 kg	160 kg
	57,5 cm long	13123120	78,5	42-48	16,6 kg	160 kg
	60 cm short	13123121	81,0	36-42	16,5 kg	160 kg
	60 cm long	13123122	81,0	42-48	16,7 kg	160 kg

Seat height rear	Seat height front	Back support height*	Transport width	Total height	Total length	Leg support length	Length when folded	Leg support angle	Rear wheel size
34-53 cm	34-56,5 cm	32-45 cm	32 cm	74-128 cm	102-122 cm	26-64 cm	76-92 cm	108°-114°	46,5-48,5 cm

* Applies to Cross back support 3A. For Cross back support 3A high applies 38-51 cm.



** With triangular back + max 7 cm

*** With solid tyre and stainless steel handrim, +1,3 kg

Cross 5	Weights and dimensions given are for a chair with 24" rear wheels with quick-release hubs, high pressure tyre, aluminium handrims, leg supports, foot supports, brakes, arm supports, 6 1/2" castors with medium forks. The measurements given may vary by ± 2%.
Cross 5 XL	Weights and dimensions given are for a chair with 24" rear wheels with quick-release hubs, massive tyres, stainless steel handrims, cross brace back, leg supports, foot supports, heel strap, brakes, arm support attachment, 6 1/2" castor wheels with medium forks. The measurements given may vary by ± 2%.

Max lateral tilt	Max tilt down	Max tilt brake	Tyre							
			High pressure 22"	High pressure 24"	Solid 22"	Solid 24"	Solid (solid inner tube) 22"	Solid (solid inner tube) 24"	High pressure 24" (Carbon)	
			PSI/Bar	110/7.5	110/7.5	-	-	-	-	110/7.6
>20°	>20°	7°		550 mm	590 mm	550 mm	600 mm	550 mm	590 mm	592
				25 mm	25 mm	32 mm	32 mm	25 mm	25 mm	23 mm

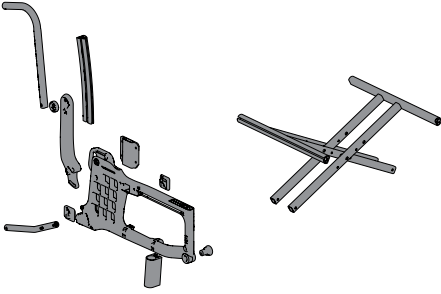
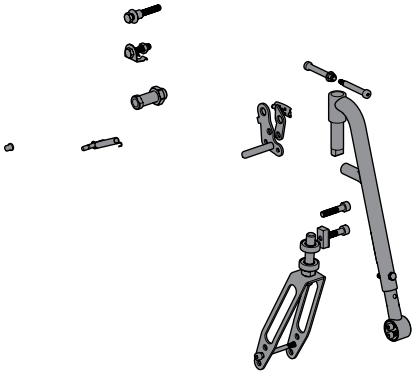
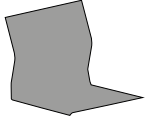
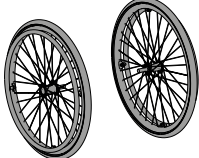
11. Technical data

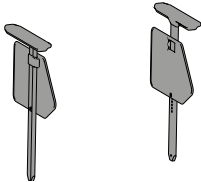
		
		
ALU	Fe*	PES
		
Fe/CF/ALU	PP/TPR	ALU/PA/PE/PU

When the device reaches end of life it can be remanufactured by Etac to get a new service life. For more information see www.etac.com or contact your local dealer.

*The front fork is available in both steel and aluminium designs. See the chair's possibilities.

12. Service and maintenance

Upholstery

The upholstery is made of two-ply polyester. The seat upholstery is fastened lengthways to the seat frame, and can easily be removed from the frame by unscrewing the end caps.

The back support upholstery is removed by loosening

the screws of the end caps and then pulling the upholstery upwards.

Wash seat and back support upholstery according to the washing instructions on the device.

Rear wheel/castor wheel, front fork attachment

Tyre/inner tube: Check the tyre pressure (see side of tyre) at least once a month, also check the tread.

Spokes: Loose spokes can lead to wheel wobble. Consult a cycle dealer or your Technical Aids Centre if it is necessary to adjust the spokes

Wheel axles: Clean the wheel axles from hair and dirt as necessary.

Ball bearings: Require no maintenance.

Handrim: Check the handrims so that they are free from scratches.

Front fork attachments:
To achieve the best operating conditions, the attachments should be installed at 90°. Check also that the front forks are correctly tightened. See section "*Mounting front fork*".

Brakes

The braking effect is dependent on the air pressure in the tyres. Encrusted dirt can have a negative effect

on the brake mechanism. Check the functioning of the brakes once a month. In the event of adjustments, see point "*Brake, adjustment*".

Washing the frame

It is important to keep the wheelchair clean, both for your own comfort and the longevity of the chair. It is equipped with drainage holes which ensure that it is easy to wash and dry.

Clean the frame with a nonabrasive cleaning agent with a pH level between 5 and 9, or with a 70% disinfectant solution. Rinse and dry.

Touch-up paint

Touch-up paint is available for minor scratches and chips in all the frame colours available for Cross wheelchairs.

Miscellaneous

If there is a fault in your wheelchair you should contact your dealer or Technical Aids Centre.

If your chair needs reconditioning or repair, only original parts from Etac or components with equal quality, as specified in Cross diagrams, should be used. Etac will not be held responsible for damage or injury caused by use of non-original parts.

When necessary lubricate moving parts/joints with bicycle oil or similar.

13. Storage and Guarantees

Methods of surface treatment:

Lacquered surfaces = Polyester powder coating or ED-coating

Non-lacquered aluminium parts = Anodized coating

Non-lacquered steel surfaces = Galvanized

Guarantee:

5 year guarantee against material and manufacturing defects.

For terms and conditions, see www.etac.com

Storage:

The device should be stored indoors in a dry place at a temperature above 5°C. If the device has been stored for a long time (more than four months), its function must be checked by an expert before use.



To be sorted according to national regulations



Etac Ltd.

Unit 60, Hartlebury Trading Estate,
Hartlebury, Kidderminster,
Worcestershire, DY10 4JB
+44 121 561 2222



Promefa AG

Kasernenstrasse 3A
8184 Bachenbülach, CH
+41 44 872 97 79



Etac Supply Center AB

Långgatan 12
SE-334 33 Anderstorp



+46 371 58 73 00



info@etac.com



www.etac.com



75190

etac[®]

Creating Possibilities