



User manual

Cross 6

etac[®]

Creating Possibilities

75401 - 241002 - Version 9

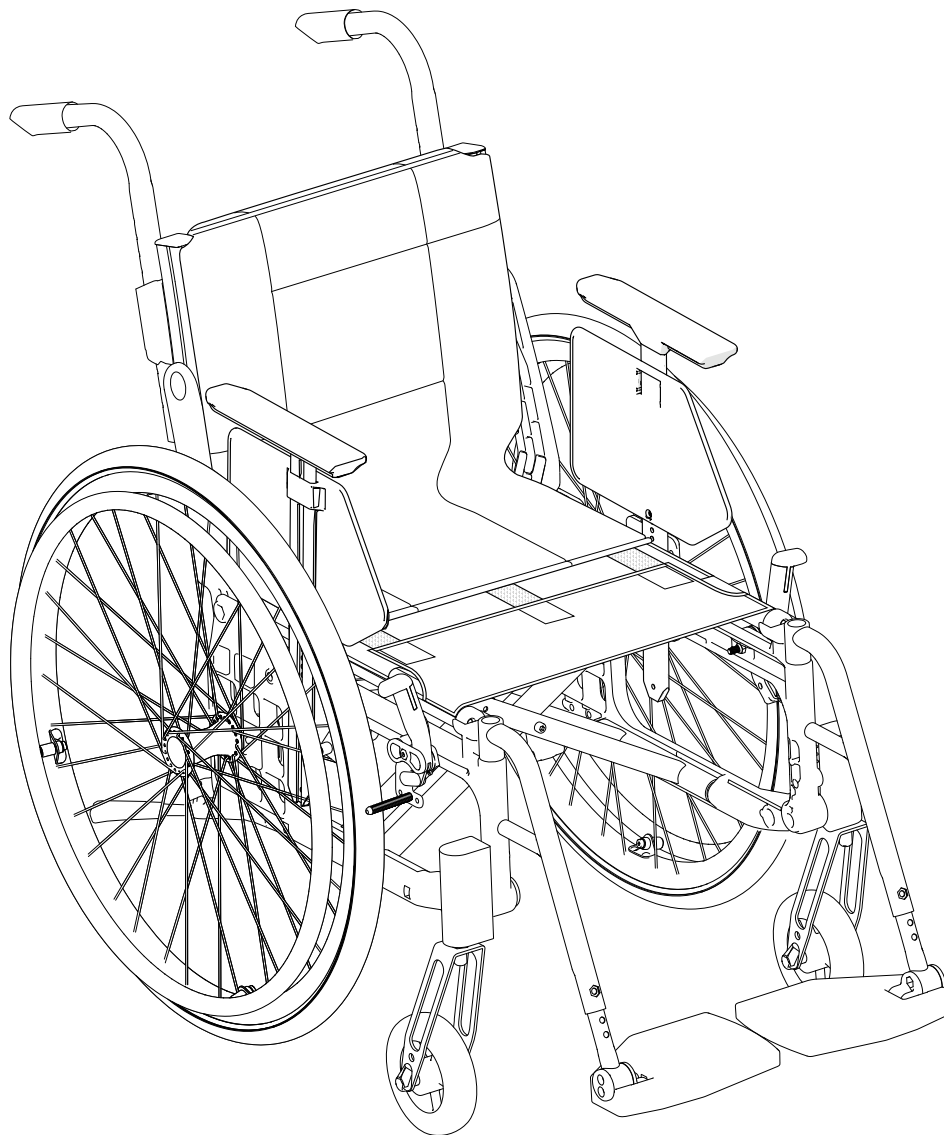

en



www.etac.com

MD

CE

Content

1. General

[Device description, Intended purpose, Intended user group, Intended environment, Intended application, Expected service life, Indications, Contraindications, Warnings, CE marking, tests, Pre-purchase information, Adverse event, Customization, Guarantee, Miscellaneous ...3](#)

2. Safety

[Symbols and warnings.....4](#)
[Transport in vehicles.....5](#)

3. Service and maintenance

[Cleaning, disinfection and other maintenance6](#)
[Troubleshooting guide.....6](#)

4. Technical data

[.....7](#)

5. Description

[.....8](#)

6. The chair's possibilities

[..... 8-10](#)

7. Accessories

[..... 10-12](#)

8. Installation upon delivery

[..... 13](#)

9. Handling

[Folding/unfolding..... 13](#)
[Rear wheels with quick-release axle..... 13](#)
[Anti-tip guard 13](#)
[Tilter 13](#)
[Leg supports.....14](#)
[Push handles/bow handle, height adjustable14](#)
[Attendant brake \(service brake/parking brake\).....14](#)

10. Seating comfort settings

[..... 15-16](#)

11. Driving technique, use

[..... 17-20](#)

12. Advanced settings, customization

[Settings.....21](#)
[Front seat height \(table\) 21-22](#)
[Rear seat height \(table\)..... 23](#)
[Height adjustment front fork attachment.....24](#)
[Angle adjustment front fork attachment24](#)
[Remove/mount front fork..... 25](#)
[Remove/mount the castor wheels..... 25](#)
[Change the rear wheel position 26-27](#)
[Change the rear wheel position, attendant brake 28](#)
[Adjust back support angle, 3A 29](#)
[Adjust back support height and lumbar angle, 3A 29](#)
[Adjust seat depth using lumbar angle, 3A 30](#)
[Mount seat extension, 3A..... 30](#)
[Adjust back support height, 2B.....31](#)
[Adjust back support angle, 2B.....31](#)

13. Settings, readjustments

[Brake, adjustment..... 32](#)
[Rear wheels with quick-release axle..... 33](#)
[Leg support, elevating 33](#)
[Amputee support 33](#)
[Anti-tip guard 34](#)
[Handrims 34](#)
[Camber angle 35](#)
[Centre of gravity/balance setting 35](#)
[Arm support..... 36](#)
[Mudguard 36](#)

14. Accessories settings

[Seat cushion and comfort wedge37](#)
[Positioning belt.....37](#)
[Head support..... 38](#)
[Head support mount..... 38](#)
[Crossbar..... 38](#)
[Attachment for chest harness..... 39](#)

1. General

Thank you for choosing an Etac product. In order to avoid damage during assembly, handling and use, it is important to read this manual and save it for future reference. You can also find it at www.etac.com. You can select your language via the "International" and "Local websites" link. Here you will also find other product documentation, such as prescriber information, pre purchase guide, and reconditioning instructions.

In this manual the User is the person sitting in the chair. The Caregiver is the person helping the user.

Information on how people with impaired vision can access the manual can be found in our presales guide at www.etac.com.



To avoid damage or injury during handling and use, this manual should always accompany the device.

Device description

Etac Cross 6 (hereafter also referred to as "the device" or "the product") is a manual wheelchair with cross-folded frame. Cross 6 is adaptive and configurable through adjustable settings, options and accessories.

Intended purpose

Cross 6 is an assistive device intended for the alleviation of or compensation for a physical impairment due to an injury or disability. The device is designed for mobility. The device is designed for hand and/or foot propulsion and/or to be pushed and steered by an assistant.

Intended user group

The user group for the device is based on the individual's functional ability and not on a specific diagnosis, health condition or age. The device is intended for individuals with a height of 146 cm or more, or a mass of 40 kg or more. Secondary users of the device are attendants providing assistance and clinicians/technicians who set up the device.

Intended environment

The device is intended for indoor and outdoor use on levelled ground and accessible terrain. It is not to be exposed to salt water. The device has fixation points for transport in motor vehicle.

Intended application

The device is intended for short-term and long-term use. The device is intended to be used with a seat cushion. The device is intended for refurbish and reuse. Follow the instructions in "Reconditioning instruction, Etac manual wheelchairs" on www.etac.com.

Expected service life

The expected service life of the device is 10 years. Preventive maintenance is recommended. Lack of maintenance may reduce the expected service life of the device. For full information on the expected service life, see www.etac.com.

Indications

Indication for use is disability, including, but not limited to, an impaired ability to ambulate.

Contraindications

There are no known contraindications.

Warnings

Warnings describing a risk element for a specific action or setting of the device can be found in the relevant section.



A defective device must not be used. Risk of injury.



Do not leave the device in direct sunlight. A hot device may cause burns



Tipping risk. Inactivated anti-tips will increase the risk of injury. Activate the anti-tips to avoid the risk of tipping.



The device can be adjusted beyond safe use! Adjustments should only be carried out by a person who understands the use of the device.

for guidance.

We are not responsible for printing errors or incomplete information.



To be sorted according to national regulations

Tools



Allen key
3, 4, 5, 6 mm



Box-end spanner
8, 10, 13, 24 mm



Spanner socket
19 mm



Screwdriver
Ph 2

Declaration of conformity

The device conforms with MDR (EU) 2017/745.

The device is tested and conforms with EN 12183 (which includes fire testing according to ISO 8191-2) and ISO 7176-19.

Pre-purchase information

Pre-purchase information can be found at www.etac.com.

Adverse event

In case of an adverse event occurred in relation to use of the device, it must be reported to your local dealer and the national competent authority in a timely manner. The local dealer will forward information to the manufacturer.

Customization

Actions outside the instructions and settings in the manual will invalidate the CE marking according to MDR 2017/745 and void the warranty.

Combinations

Risk-managed combinations between Etac devices and devices from other suppliers are presented in the combination list on www.etac.com.

Guarantee

5 year guarantee against material and manufacturing defects. For terms and conditions, see www.etac.com

Miscellaneous

Etac regularly improves its products. We therefore reserve the right to modify the products without prior notice. The dimensions given on drawings or other material are solely

2. Safety

Symbols

These symbols appear in the manual.



Warning, precaution or limitation



Useful advice and tips.



Material for recycling



Click on the icon or scan the QR code for video



Showing **1** of two options



Showing **2** of two options



Showing **1** of three options



Showing **2** of three options



Showing **3** of three options

Symbols

These symbols appear on the device.



Tipping risk. Inactivated anti-tips will increase the risk of injury. Activate the anti-tips to avoid the risk of tipping.



Detachable part, do not lift!

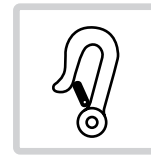

Anchoring. Fixing points for the clamping system for transport in motor vehicles.



The product complies with ISO 7176-19.

Product label

Article information.

Product	Serial no.	Bar code acc. to GS1-128 GTIN-14 and serial no.*	
XXXXXXXXXX	SN XXXXXXXXX	[UDI] [XXXXXXXXXX]	
[MD] Max XXX kg	REF XXXXXXXXX		[YYMMDD]
Maximum user weight	Item no.		Date of manufacture

*The device's date of manufacture can be read from the barcode on the device. The number 11 is shown below the barcode in brackets. The number combination after these brackets is the date of manufacture.

2. Safety

Transport in vehicles

The product is crash tested and approved according to ISO 7176-19 (see section "CE marking, tests" in the manual).

Etac recommends in the following order:

- 1) The user moves to a vehicle seat and uses the vehicle's three-point belt during transport. The wheelchair is then placed securely in the luggage compartment or in the back seat so that it can't overturn or roll.



- The wheelchair should primarily be placed in the luggage compartment.
- If the wheelchair is placed in the back seat, make sure it can't overturn or roll. If possible, secure it with the car's seat belt.

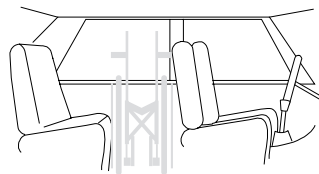

- 2) The wheelchair is anchored forward in the vehicle according to this manual, the user uses a separate three-point belt that is anchored in the vehicle.

Anchoring

- Rear transport bracket must be used.
- The anchoring device must not be pulled through the wheels or around the back posts.
- Accessories that can be detached without tools must be removed and clamped (excluding arm supports, leg supports, and positioning accessories)
- If head support is mounted other than with head support bracket 3A, cross bar must be used.



This is the way the wheelchair is tested and approved according to ISO 7176-19:

- Clamping device UNWIN_WWR/ATF/K/R according to ISO 10542.
- Three point strap 907523, Klippan Safety AB.
- Parking brakes activated.
- Anti-tip guards activated.
- Head support bracket 3A and head support.
- Rear wheels with handrims.

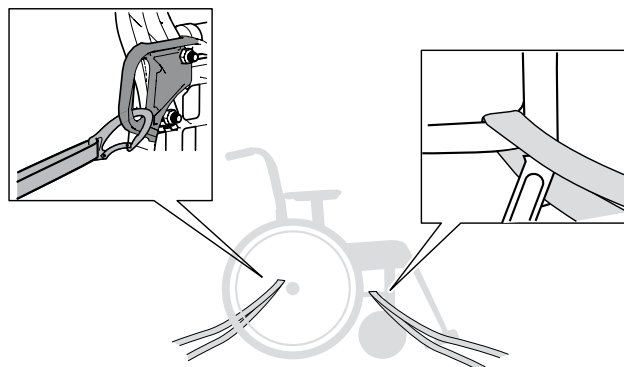
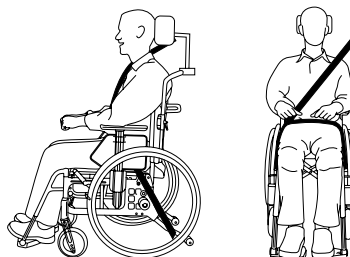
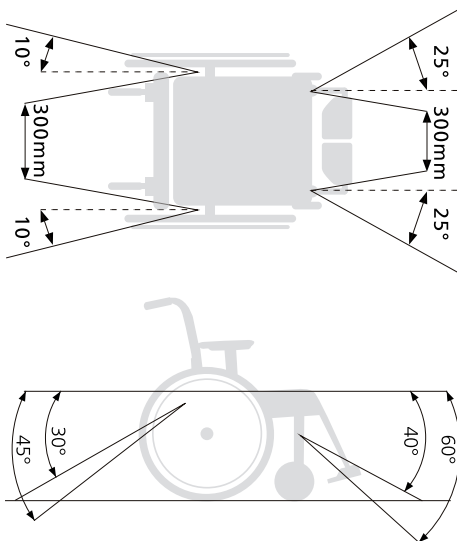

- 3) Pursuant to Directive 2001/85/EC, Annex VII, point 3.8.3. in vehicles, there may be specially marked wheelchair spaces that allow transport with the wheelchair facing the direction of travel. If this mode of travel is used, the user/attendant must be active in the ride, be prepared for sudden movements and have the ability to maintain a safe sitting position throughout the transport. The user's disability must not be to such an extent that he cannot hold on himself and the wheelchair to the handle mounted in the vehicle in the event of changes in speed or direction.



- Parking brakes activated.
- Anti-tip guards activated.
- Head support.
- Positioning belt should be used.
- Accessories that can be detached without tools must be removed and clamped.

3. Service and maintenance

Cleaning

Back upholstery, seat upholstery and arm support upholstery:

Wash as per the washing instructions on the device

Chassis, handle and arm supports:

Everyday maintenance: Clean the chassis with commonly used cleaning agents without abrasives that have a pH value between 5 - 9. Rinse and dry.

Disinfection

With 70% disinfectant. Allow to air dry. Cleaning in addition to everyday maintenance/reconditioning: See reconditioning instructions at www.etac.com.

Observe the disinfectant manufacturer's user and safety instructions.

Other maintenance

Rear wheels/castor wheels

Tyre/tube: Check tyre pressure (see tyre side) at least once a month, and also tyre tread.

Spokes: Loose spokes can cause warped wheels. Contact a bicycle shop or technical aids centre if you need to adjust the spokes.

Wheel axles: Clean rear wheel and castor wheel axles from hair and dirt if necessary.

Bearings: Maintenance-free.

Handrim: Check the handrims so that they are free from scratches.

Front fork attachments:

For best driving characteristics, the mounts must be set perpendicularly. Also check that the front forks are properly tightened. See section "*Removing/mounting front fork*".

Brakes

The effect of the brakes depends on the tyre pressure. Heavy soiling can adversely affect the braking mechanism. If adjustment is required, see section "*Brake, adjustment*".

Touch-up paint

For minor scratches and lacquer damage, touch-up paint is available in all the frame colours of the device.

If necessary, lubricate moving parts/joints with bicycle oil or similar.

Other

If something on your wheelchair does not work, contact your prescriber or technical aids centre.

When reconditioning and replacing parts, original Etac parts or components of similar quality should be used. When using other parts, Etac is not responsible for function and safety.

Storage

The device should be stored indoors in a dry place at a temperature above 5 °C. If the device has been stored for a long time (more than

four months), its function must be checked by an expert before use.

Troubleshooting guide

The wheelchair is pulling sideways	<ul style="list-style-type: none"> • Pump the tyres • Check and adjust the height and angle of the front fork attachments • Check that the rear wheel brackets are correctly mounted • The user load is uneven on the wheelchair • The propulsion is stronger on one side
The wheelchair is "hard" to drive	<ul style="list-style-type: none"> • Pump the tyres • Check that the rear wheel brackets are correctly mounted • Clean hair and dirt from the castor wheel axles • Too much weight over the castor wheels, adjust the wheelchair's balance position
The wheelchair is "hard" to turn	<ul style="list-style-type: none"> • Pump the tyres • Make sure that the front forks are not too tight • Clean hair and dirt from the castor wheel axles • Too much weight over the castor wheels, adjust the wheelchair's balance position
The brakes are bad	<ul style="list-style-type: none"> • Pump the tyres • Adjust the distance between the tyre and the brake
The rear wheels are "loose"	<ul style="list-style-type: none"> • Adjust the length of the hub shaft
The rear wheels are difficult to remove/put on	<ul style="list-style-type: none"> • Lubricate and clean the quick-release coupling, with e.g. bicycle oil • Adjust the length of the hub shaft
The castor wheels are "wobbling"	<ul style="list-style-type: none"> • The front axles are not tightened hard enough • Check and adjust the height and angle of the front fork attachments • Too much weight over the castor wheels, adjust the wheelchair's balance position
The wheelchair is difficult to fold/unfold	<ul style="list-style-type: none"> • The upholstery is too tight • Lubricate and clean the cross sections under the seat
The wheelchair feels "unsteady"	<ul style="list-style-type: none"> • Pump the tyres • Make sure screws and controls are tightened properly

4. Technical data

Chair type	Art no	Total width	Seat depth from back post *	Weight
35 cm short	13240101	55,5 cm	36-49 cm	14.6 kg
35 cm long	13240102	55,5 cm	42-55 cm	14.8 kg
37.5 cm short	13240103	58,0 cm	36-49 cm	14.7 kg
37.5 cm long	13240104	58,0 cm	42-55 cm	14.9 kg
40 cm short	13240105	60,5 cm	36-49 cm	14.8 kg
40 cm long	13240106	60,5 cm	42-55 cm	15.0 kg
42.5 cm short	13240107	63,0 cm	36-49 cm	14.9 kg
42.5 cm long	13240108	63,0 cm	42-55 cm	15.1 kg
45 cm short	13240109	65,5 cm	36-49 cm	15.1 kg
45 cm long	13240110	65,5 cm	42-55 cm	15.3 kg
47.5 cm short	13240111	68,0 cm	36-49 cm	15.2 kg
47.5 cm long	13240112	68,0 cm	42-55 cm	15.4 kg
50 cm short	13240113	70,5 cm	36-49 cm	15.3 kg
50 cm long	13240114	70,5 cm	42-55 cm	15.5 kg
52.5 cm short	13240115	73,0 cm	36-49 cm	15.4 kg
52.5 cm long	13240116	73,0 cm	42-55 cm	15.6 kg

Max user weight	Seat height back	Seat height front	Back support height	Transport width
135 kg	32-53 cm	32-56.5 cm	32-45 cm 38-51 cm	32 cm

Total height	Total length	Leg support length	Length collapsed	Leg support angle
72-116 cm	80-122 cm	26-64 cm	62-86 cm	108°-114°

Handrim size	Maximum tilt sideways	Maximum tilt down	Maximum tilt brake
46.5-58 cm	>20°	>20°	>7°

Weights apply to a chair with 24" rear wheels, high-pressure tyres, aluminium handrims, handles, leg supports, foot plate, brake, arm support mount, 6 1/2" castor wheels and medium fork. Dimensions stated can vary ± 2%.

* With Cross brace 2 36-42/42-48 cm

Tyre

	High pressure 22"	High pressure 24"	Solid 22"	Solid 24"	Solid (solid inner tube) 22"	Solid (solid inner tube) 24"	High pressure 24" (Carbon)
	110/7.5	110/7.5	-	-	-	-	110/7.6
	550 mm	590 mm	550 mm	600 mm	550 mm	590 mm	592
	25 mm	25 mm	32 mm	32 mm	25 mm	25 mm	23 mm



ALU	Fe*	PES	Fe/CF/ALU
PP/TPR	ALU/PA/PE/PU		

When the device reaches end of life it can be remanufactured by Etac to get a new service life. For more information see www.etac.com or contact your local dealer.

*The front fork is available in both steel and aluminium designs. See the chair's possibilities.

5. Description/Standard version

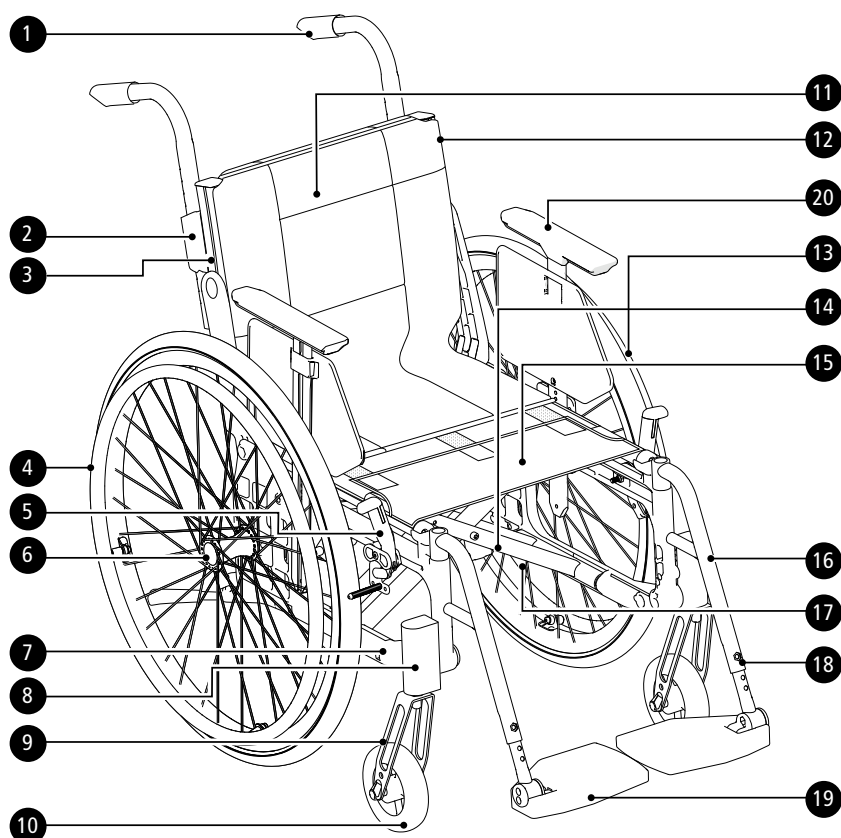

1. Handles
2. Steering handle lock
3. Back rail
4. Handrim
5. User brake
6. Quick release
7. Gable
8. Front fork attachment
9. Front fork
10. Castor wheel
11. Back cover
12. Upholstery back
13. Rear wheel
14. Cross
15. Upholstery seat
16. Leg support
17. Article and serial numbers*
18. Steering wheel foot lock
19. Footplate
20. Arm support

*The device's date of manufacture can be read from the barcode on the device. The number 11 is shown below the barcode in brackets. The number combination after these brackets is the date of manufacture.

6. The chair's possibilities

In the section "The chair's possibilities" you can see all the adjustments that can be made to the wheelchair. Additional "Odd combinations" exist, e.g. in terms of rear wheels, castor wheels and back model. Contact customer service.

For more information about the chair's possibilities, see www.etac.com

Seat height	Front	32-56.5 cm	
	Back	32-53 cm	
Seat angle	Max forward angle: 2 cm lower than back (3°) Max backward angle: 6 cm higher than back (9°)		
Castor wheel	4" solid (max user weight 100 kg) 45 or 57 mm hub width		
	5" solid 45 or 57 mm hub width		
	6" solid 45 or 57 mm hub width		
	6.5" solid 57 mm		
	6" solid soft 57 mm		
	7" solid soft 57 mm		
	8" solid soft 200x35 or 200x50 57 mm hub width or 200x38 45 (solid)		
Front fork	Extra short (two height positions for castor wheels) steel, for 57 mm hub width		
	Short (three height positions for castor wheels). 3 or 4 mm thick steel, for 57 mm hub width		
	Medium (three height positions for castor wheels). 3 or 4 mm thick steel, for 57 mm hub width		
	Long steel, for 57 mm hub width		
	XS, aluminium, for 45 mm hub width		
	S, steel, or aluminium, for 45 mm hub width		
	M, steel, for 45 mm hub width		

6. The chair's possibilities

Rear wheel	20" (C5 or C6)		
	22" (C5 or C6)		
	24" (C5 or C6)		
	24" Carbon (not with attendant brake)		
	25" Maxx		
	26" (C5)		
Handrims	Aluminium		
	Stainless steel		
	Plastic		
	Foam rubber (not with attendant brake) (not for C6 or Maxx)		
	Titanium (not with attendant brake) (not for C6 or Maxx)		
Camber angle	2°		
	0°		
Seat	Seat upholstery		
	Hard seat		
Back support 3A/ Back support 3A high		Back 3A	Back 3A high
	Height	32-45 cm	38-51 cm
	Hip angle	-5° - +20°	-5° - +20°
	Lumbar angle	-16° - +16°	
Seat depth	Short frame 36-49.5 cm		
	Long frame 41-55.5 cm		
Back support mod. 2	Height 30-45 cm, angle -5° - +15°. Standard		
	Height 30-45 cm, angle -5° - +15°. Widened		
Seat depth back support mod. 2	Short frame 36-42 cm. Long frame 42-48 cm. Func: Short frame 42-48 cm. Long frame 48-54 cm.		
Back support upholstery	Adjustable upholstery		
Back support cover	Standard		
	Comfort		
	Tidy, wipeable		
Back support Axiom	Various designs regarding width, height and contour		
Push handles/ Bow handle	Height-adjustable push handles with 2 cm intervals. Detachable.		
	Height-adjustable bow handle with 2 cm intervals. Detachable.		
	Height-adjustable bow handle with 2 cm intervals. Detachable. Angle adj. (not with 3A back sw35)		
Fixed push handles	Ri/le fits Cross back support 3A		
Fixed back with fixed push handles, 2B	Height low back 35-40 Height high back 42.5-47.5 Angles -5 to +15		
Leg supports, detachable swing-away	Normal knee angle		
	Narrow angle (fits only with 5" castor wheels)		
	Narrow angle short		
Leg supports lockable	Normal knee angle		
	Narrow angle		
	Narrow angle short		

6. The chair's possibilities

Leg supports Elevating	Elevating with folding calf plate from 40 cm seat width	
	Elevating with cushion console and padded folding calf plate.	
	Elevating with folding cushion console and padded calf plate.	
Leg supports other	Plaster cast leg supports	
	Amputee leg support	
	Amputee weight	
Arm support	Height adjustable, 25 cm long, solid plate, black	
	Height adjustable, 38 cm long, solid plate, black	
Foot supports	Std Max length: 51 cm. Min length: 33 cm.	
	Extended attachment tubes +10 cm	
	Shorter attachment tubes -8 cm	
	One-piece foot support	
	One-piece foot support compl for 35-37.5 seat width, angle adjustable, height and depth adjustable	
Front fork attachment	Low, widened	
	Standard H100or H142(for fork with 45 mm hub width)	
	Widened 6 cm H100	
User brake	Angled handle red	
	Angled handle black	
	Extended handle	
	Single hand brake (standard or angled handle)	
Attendant brake	Brake handle 75 mm opening grip	
	Brake handle 100 mm opening grip	
Single-hand drive	For the right or left side. Telescopic shaft, easy to detach when folded (not with attendant brake)	
Colour frame	01 = Black 92 = White 78 = Grey	

7. Accessories

Installation instructions are included with all accessories when delivered from Etac. You can find them and more info about the accessories on our website www.etac.com.

Settable = Adjustable using tools. Adjustable = Adjustable without tools.

Arm support	Short 26 cm	
	Long 36 cm	
	Foldable short 26 cm	
	Foldable long 36 cm	
Cover arm support	Detachable, 25 alt 38 cm long padded alt gel, dark grey plush alt black Hygiene. Fits arm support with solid plate.	
Arm support pad hemi	Swivel for mounting on long arm support	
Filler cushion	Reduces the width between the arm supports	
Arm support locking kit	Locked arm support is not detachable but free for height adjustment	
Side protection	Black	
Mudguard	Right or left	
Thigh support		
Thigh support	With soft pad	
Distal thigh support Add-On	Padded. Helps to align the femur, position the knees in a more neutral position and to control abduction.	
Widening kit	To move the rear wheels, brake and arm support 5 mm per side	

7. Accessories

Tray	Transparent, mounted on long arm supports	
Hemi tray	Transparent, Width 35-50 cm Can be mounted on short or long arm supports.	
Anti-slip hemi tray		
Hemi tray/Communication tray half	Right/left	
Seat extension	Mounted at the rear with a 3A back support	
Seat cushion	Dark grey plush and black velour, 56 cm long, cut to adjusted seat depth, washable	
Seat cushion Tidy	Water repellent, wipeable	
Comfort wedge	For the cushion, levels off the front of the seat	
Cover for calf plate	On elevating leg support, black Hygiene	
Calf strap	Detachable, black nylon, adjustable in length	
Padding	For calf strap	
Calf pad	Plush. Mounted/adjusted with Velcro	
Heel strap	Black nylon, adjustable in length	
Foot plate, padding	For foot support depth 13 cm	
	For one-piece, angle adjustable foot plate	
Extended foot plate	Mounted on existing foot plate, seat width 40-55 cm	
Extended foot support Add-on	Fits onto the existing footplate, from seat width 35-52,5 cm. Extends the depth of the foot supports to 22.5 cm	
Sideprotection foot plate Add-on	Mounted on extended foot plate	
Foot box	Padded. Securely contains the feet, while still allowing some movement. Medium or large	
Positioning belt	Two-piece with snap-fit buckle, fixing points on the wheelchair frame	
Seat belt	With snap-fit buckle	
Attachment, chest harness	Only in combination with head support	
Head support, traditional	Adjustable in height, depth and angle. Available in several models	
	With side support. Adjustable in height, depth and angle.	
Head support attachment 3A	For Cross 3A back support, mod 4	
Head support attachment	For mounting on chassis	
Cross-brace (for back support)	For Cross 3A back support. With snap-fit buckle	
Cross-brace (for back support)	For Cross 2 back support. With snap-fit buckle	
Back wedge	Three different sizes, attached with Velcro. Provides support and shape in back support. The wedges can also be combined with other accessories and adapted to the desired size, and several wedges can be built together.	13x9.5x2 cm
		19x12x2 cm
		20x17x2.5 cm
	Dark grey plush	15 cm 30 cm
Side cushion	Provides light side support. Used in cases where trunk supports are too stabilizing. (Combined with arm supports and side stops if needed)	
Side stop	Combined with wedge or side support cushion. Creates a more distinct stop and holds wedge or side support cushion in place	Straight
		Angled, 3 cm
Lateral support	Adjustable in height, depth and width and detachable.	
Lateral support	Swing-away and detachable. Adjustable in height, depth and width	
Lateral support	Cross 3A back support, PUR or Hygiene	
Lateral support	Cross 3A back support, swing-away, medium or large cushion	

7. Accessories

Anti-tip guard	Telescoping foldable, adjustable in height, adjustable in length and angle		
Cane holder	Two piece of which the elastic part is attached around the cane post		
Drip stand	Bracket and stand		
Oxygen holder	Maximum load 5 kg		
Spoke guards	With grey or yellow colour print		
Tetra quick release adapter	For users with reduced hand function		
Combinations	Motor unit		
	Head support		
	Seat cushions		
	Belts and harnesses		

8. Installation upon delivery

Leg supports with foot plates and arm supports/side covers are delivered unassembled and must be mounted upon delivery.

9. Handling



Unfolding

- Push one seat post down, with your whole hand on top of the seat.
- Fold down the foot plates.



Do not hold the seat tube when unfolding the wheelchair. Risk of injury.

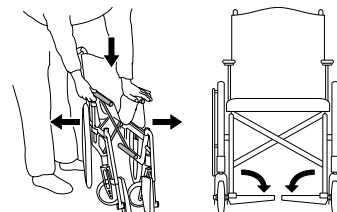

Folding

- Any drive handle and/or crossbar are detached/unclipped.
- Fold up the foot plates.
- Lift the seat up.

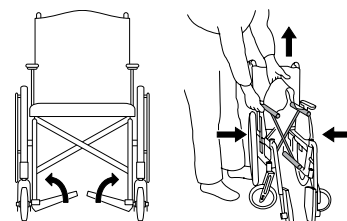

Rear wheels with quick-release axle



When attaching the rear wheels, make sure that the quick-release button fully returns. Test by pulling the wheel. Risk of injury.

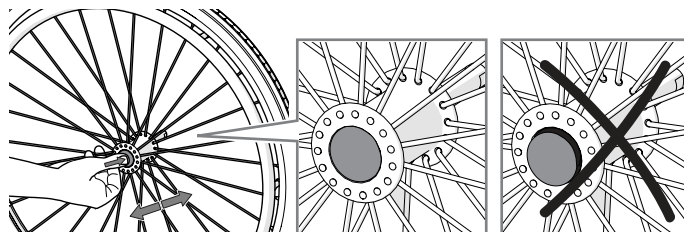

Anti-tip guard

- The anti-tip guards are foldable in two locking positions. The first locking position may be required if the anti-tip guard pushes against the back chassis.
- When unfolding the anti-tip guard, make sure that the locking pin snaps in properly.

3-7 cm

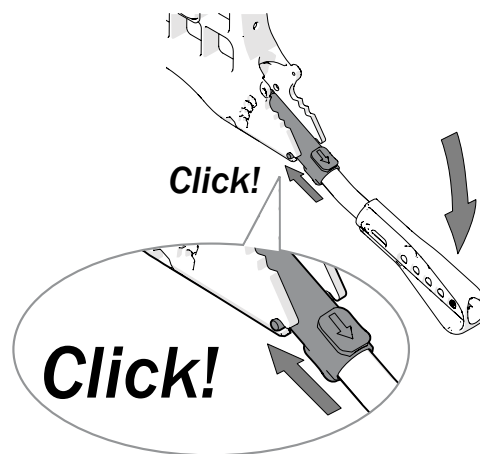
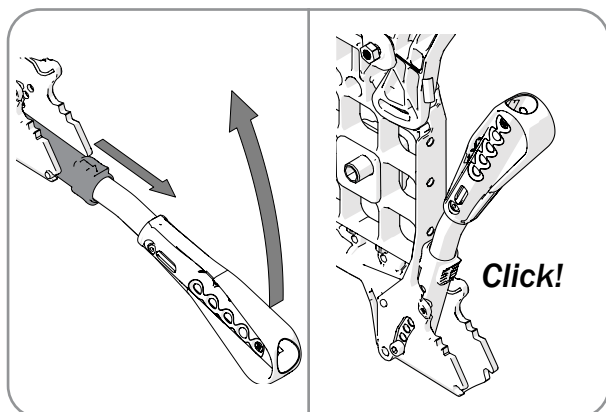

- After all adjustments to the chair, the function of the anti-tip guard must be checked. If the anti-tip guard needs to be adjusted, contact your technical aids centre.

Tilter is integrated in the frame

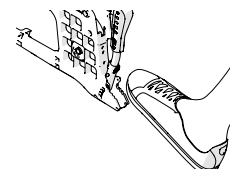

9. Handling

Leg supports/Lockable leg supports

The leg supports can be lifted off/swung to the side if needed. Lockable leg supports by pressing the red button (A).

When installing lockable leg supports, press the red button (A), place the leg support in position and release the button. The leg support is now locked (B).

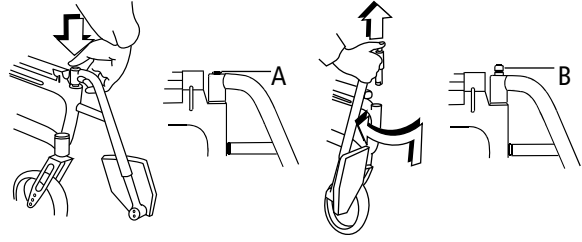

Check that the lockable leg supports are locked before lifting. Risk of injury.

Push handles/bow handle, height adjustable, angle adjustable

Release the locking handle. Set the desired height position. Make sure the handles are in a "snap-in" position, lock the locking handle.



Make sure the locking handles are properly locked and that the safety buttons have popped out below the brackets.



The bow handle must be removed before the chair can be folded.

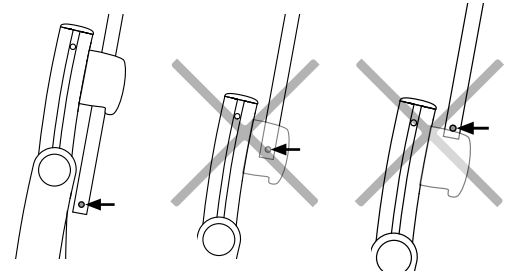
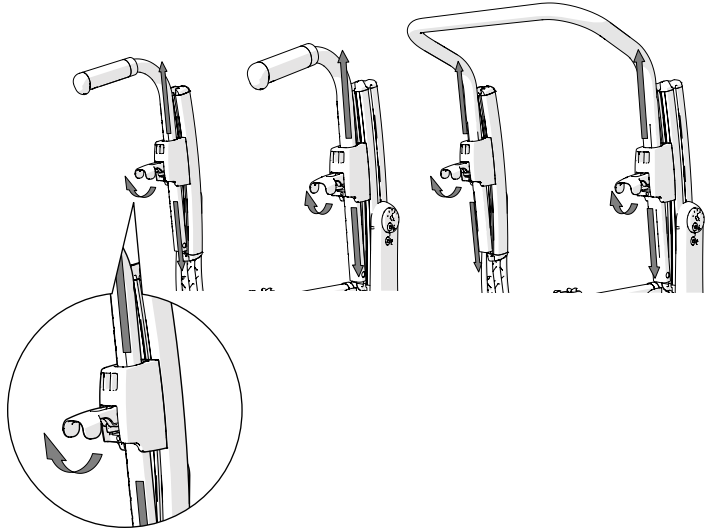

Cross 2 back support

Release the knob (A), push in the red wedge. Then as above.

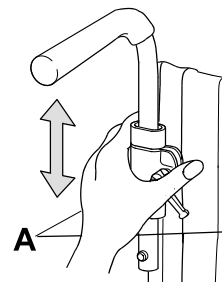

Attendant brake (service brake)

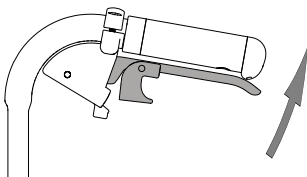

- Brake during travel by pulling the brake lever upwards.

Attendant brake (parking brake)

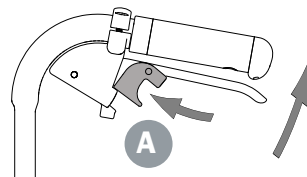

- To activate the parking brake, pull the brake lever upwards and press the A button.
- Release by pulling the handle upwards.

10. Seating comfort settings

Seating comfort

What constitutes good seating comfort depends on the needs and condition of each individual. Here are some general guidelines to consider when making the settings.

Choose a seat cushion with care. In addition to comfort, it affects stability and thereby freedom of movement. Seat cushions also have different degrees of pressure distribution.

The back support setting is a combination of angles, height and shape. Therefore, the angular settings and height of the back support may also need to be fine-tuned when adjusting the back upholstery.

Back cover

- Slacken all back straps, but make sure the Velcro straps still lock against each other.
- Position the back cover so that it covers the upper edge of the back rails and forms a crease between the seat and back support so that the user can “sit” properly on the seat.

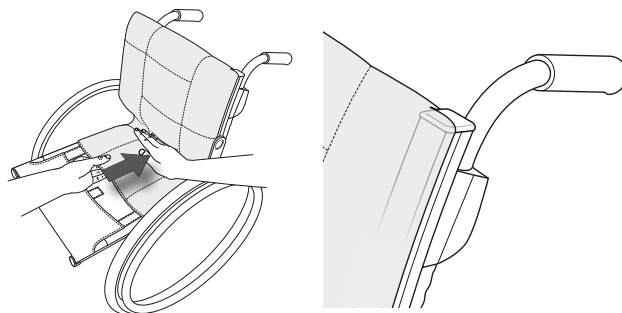

Seat cushion

- Make sure the seat depth is set correctly.
- Place the cushion so far back on the seat that the rounded corners go in between the back support rails.
- Measure the appropriate length for the seat cushion, and cut it according to the instructions provided.
- For a more contoured seat cushion, it can be supplemented with a comfort wedge, which is placed in the pocket on the underside of the seat cushion.

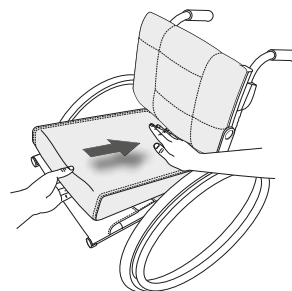

Back upholstery

Adjustment of the back upholstery is done with the user sitting in the wheelchair.

- Make sure the user sits as far back as possible on the seat.
- Support the pelvis by tightening the strap placed just below the trunk.
- Then adjust the upper strap so that the user gets support and balance in the upper body.
- The other straps are adjusted to leave space for the seat and follow the natural rounding of the back.

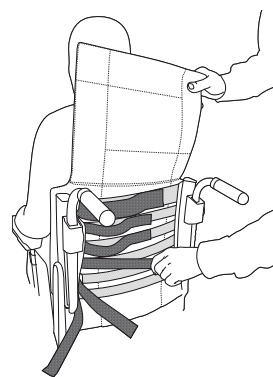

Tipping risk. Inactivated anti-tips will increase the risk of injury. Activate the anti-tips to avoid the risk of tipping.



Do not over-tighten the top straps as this affects the folding of the cross, i.e. the seat posts lock against the frame.

Back angle

The back angle may need to be adjusted when setting the back upholstery shape.

Contact your prescriber.

10. Seating comfort settings

Foot plates

Adjust the height so that your feet feel supported and your thighs rest against the cushion.

For outdoor use, the foot plates should be 4 - 5 cm from the ground.

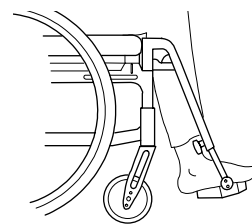

Angle adjustment

Adjust the angle of the foot plates so that the ankles are at a 90° angle.

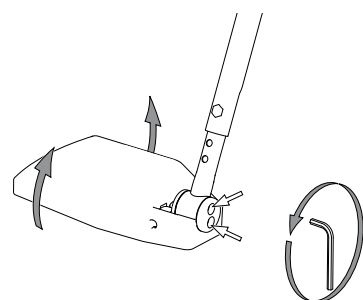

5 mm

Height adjustment

Loosen the locking knob completely on the leg support. Undo the screw. Adjust the height. Install screw and knob. Tighten properly.

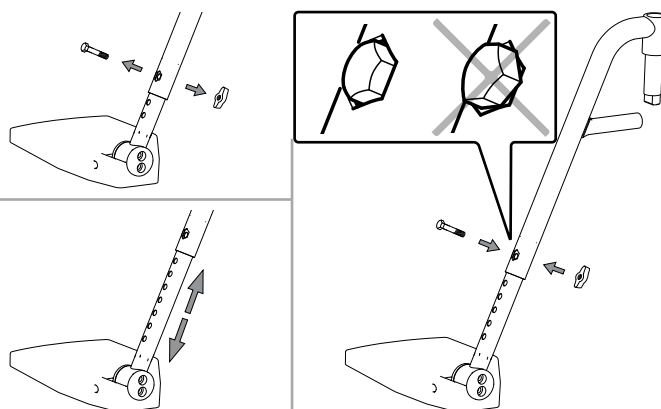

Changing the depth of the foot plates

Adjust the depth of the foot plates by switching the left and right foot plates. Don't forget to adjust the angle.

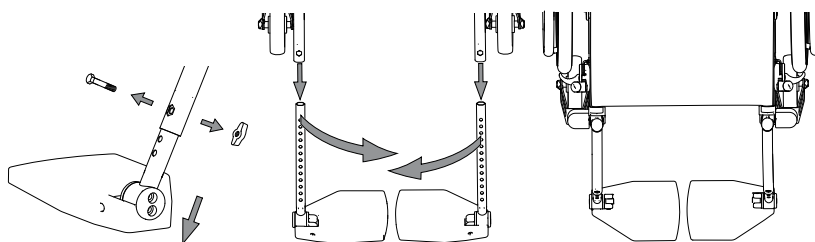

Calf/Heel strap

- Adjust the length so that the middle part of the feet are on the foot plates.

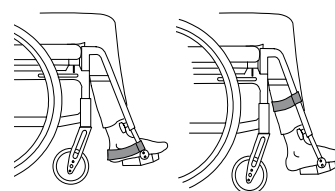

11. Driving technique use



Parking

Turn the castor wheels forward, apply the brakes.

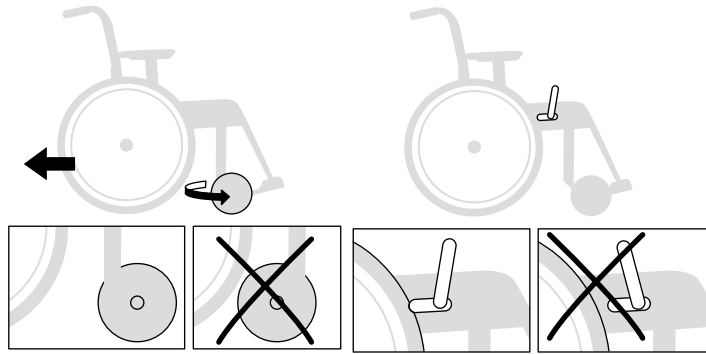

Transfer to/from a wheelchair

Turn the castor wheels forward, apply the brakes, fold up the foot plates and swing away the leg supports.

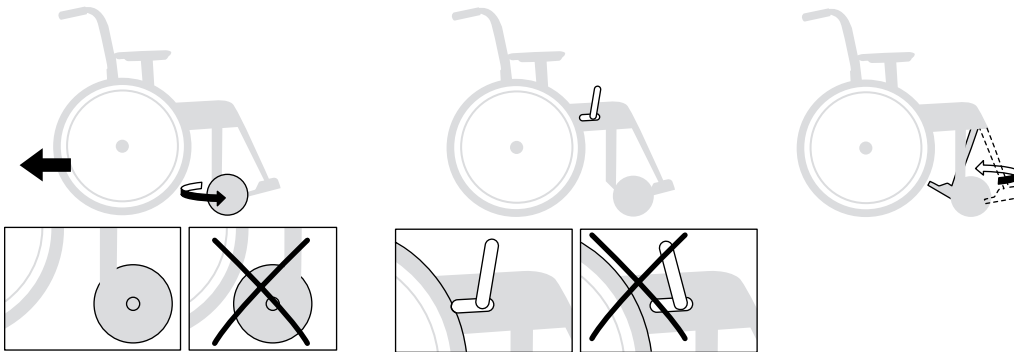
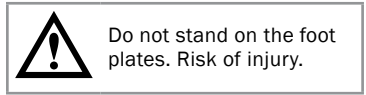

Sideways

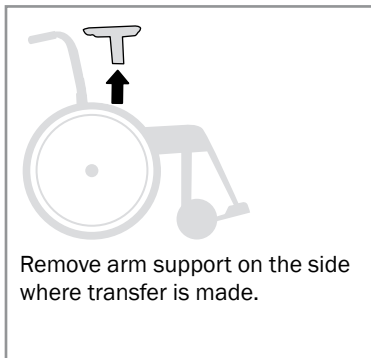

From the front

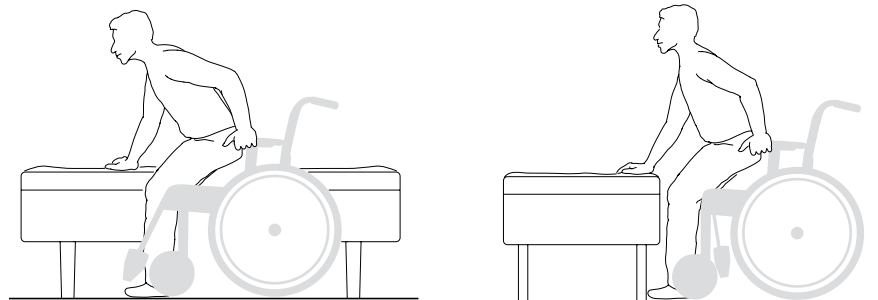

Lift off wheelchair

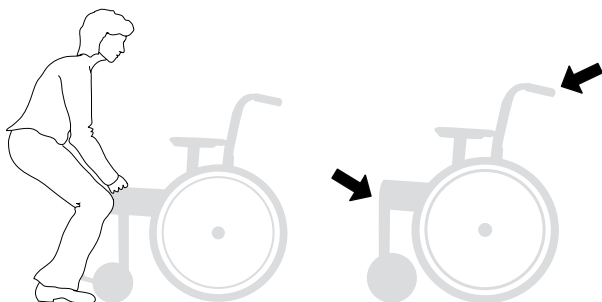

Lift the wheelchair by the push handles and the front upper part of the frame or by lockable leg supports. Remove or swing non-lockable leg supports (fixed, elevated, amputee) in under the seat.

Before lifting in the push handles, make sure the locking handles are properly locked and that the safety buttons have popped out below the brackets.

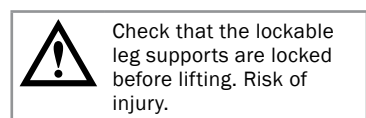

11. Driving technique use

 The following sketches show principles for driving technique and dealing with obstacles.



Tipping risk. Inactivated anti-tips will increase the risk of injury. Activate the anti-tips to avoid the risk of tipping.

User, up forwards

This technique is only recommended for experienced wheelchair users.

- Make sure the anti-tip guards are inactive.

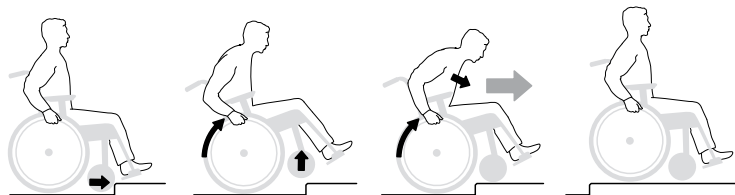

User, up backwards

This technique only works with a low edge/threshold, depending on the height adjustment of the foot plates.

- Make sure the anti-tip guards are inactive.

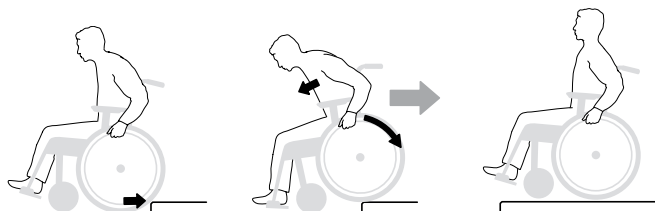

User, down forwards

This technique is only recommended for experienced wheelchair users.

- Make sure the anti-tip guards are inactive.

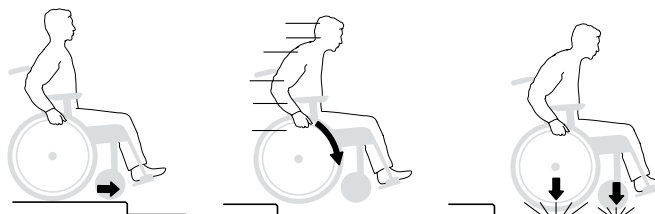

User, down backwards

This technique is only recommended for experienced wheelchair users.

- Make sure the anti-tip guards are inactive.

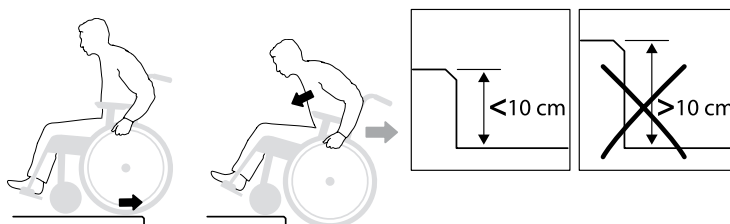

11. Driving technique use

 The following sketches show principles for driving technique and dealing with obstacles.

 Tipping risk. Inactivated anti-tips will increase the risk of injury. Activate the anti-tips to avoid the risk of tipping.



Attendant, up forwards

- Make sure the anti-tip guards are inactive.

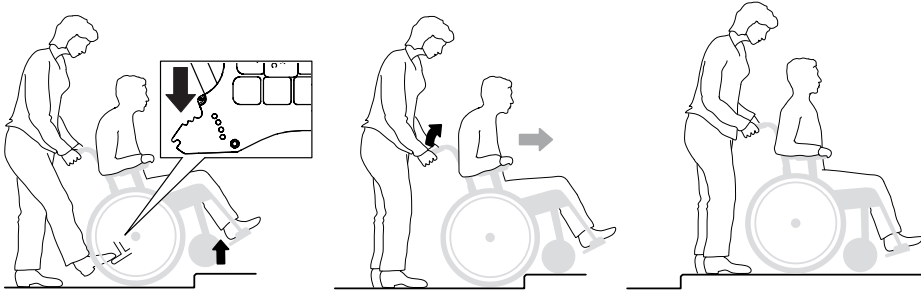

Attendant, up backwards

- Make sure the anti-tip guards are inactive.

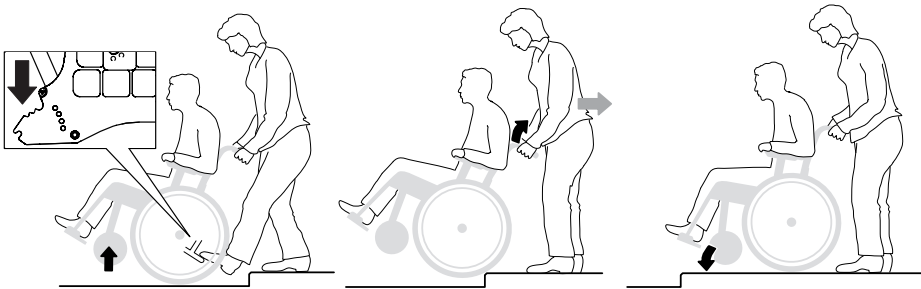

Attendant, down forwards

- Make sure the anti-tip guards are inactive.

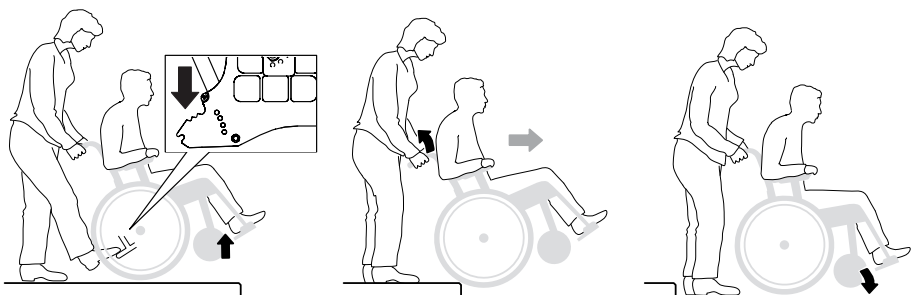

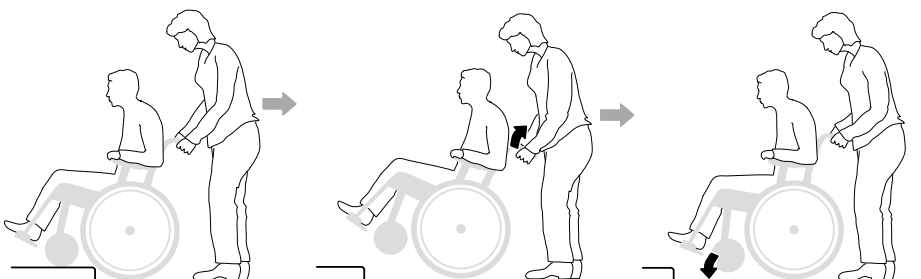

Attendant, down backwards

- Make sure the anti-tip guards are inactive.



11. Driving technique use

 The following sketches show principles for driving technique and dealing with obstacles.

 Tipping risk. Inactivated anti-tips will increase the risk of injury. Activate the anti-tips to avoid the risk of tipping.



Stairs, up

- Make sure the anti-tip guards are inactive. Never use escalators, even if there is an attendant. Make sure that height adjustable handles are tightened.

We recommend that there always be two attendants in this move. One who goes behind and holds the handles and one who goes in front and holds the frame (or the leg supports if they are lockable).

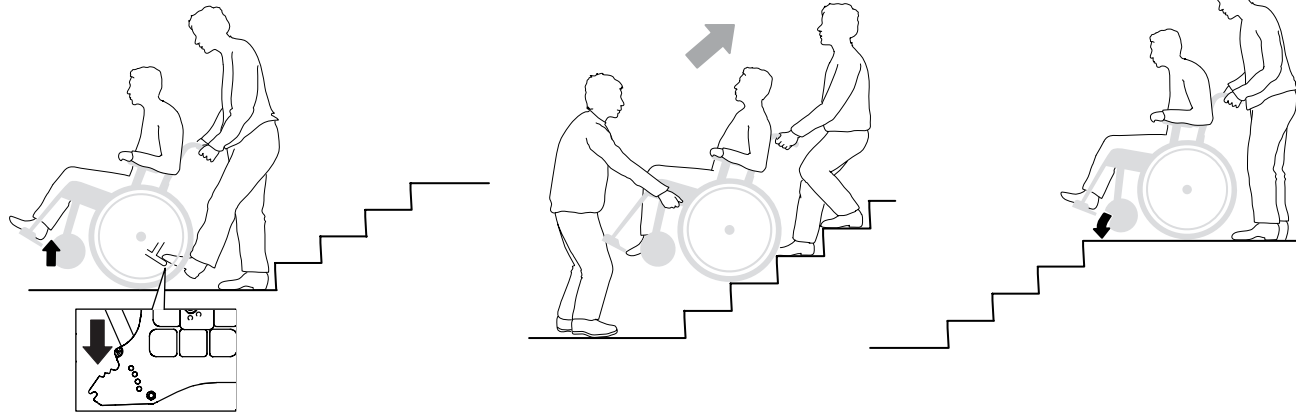

Stairs, down

- Make sure the anti-tip guards are inactive. Never use escalators, even if there is an attendant. Make sure that height adjustable handles are tightened.

We recommend that there always be two attendants in this move. One who goes behind and holds the handles and one who goes in front and holds the frame (or the leg supports if they are lockable).

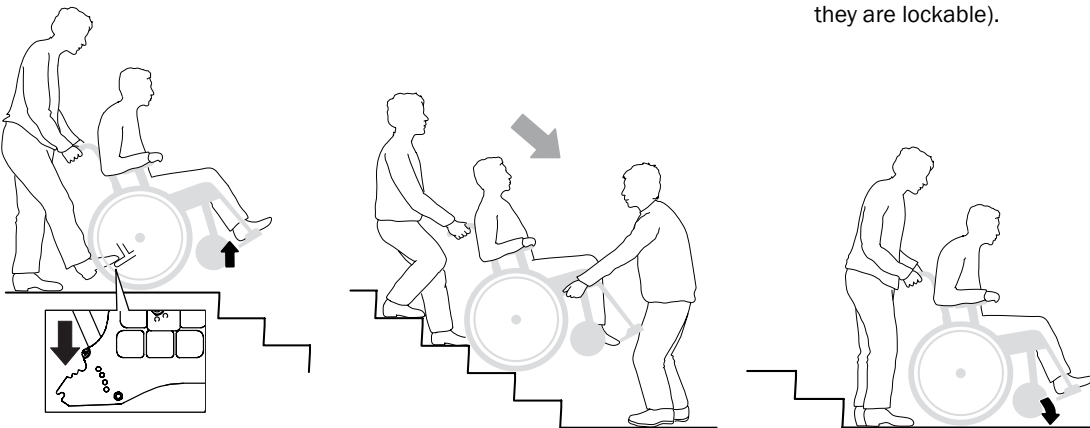

Driving uphill/downhill

Check your speed with the handdrims, not with the brakes!
Avoid turning in the middle of a hill. Always drive as straight up/down as possible. If you are unsure, ask for help.

Uphill
Tilt your body forwards to correct the centre of gravity.

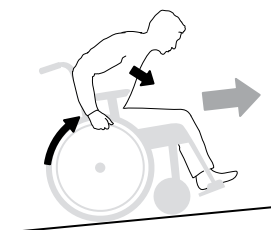

Downhill
Tilt your body backwards to correct the centre of gravity.

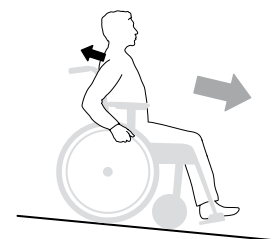

Foot propel

The user propels the wheelchair with one or two feet.

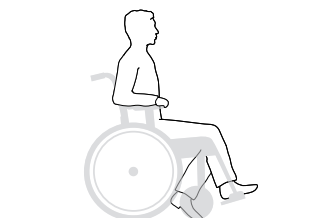

12. Advanced settings, customization

The seat angle is obtained by the difference between front and rear seat height.

At changed seat angle:

- Adjust the angle of the front fork attachments.
- Check the back support angle.

The seat depth can be adjusted by lifting the front seat upholstery and moving it backwards/forwards.

With Cross back support 3A, the seat depth can be extended by using the back support adjustment (see section "Adjusting the seat depth using the lumbar angle, 3A").

Seating comfort

After adjusting the seat height, seat angle, seat depth and back angle, the back upholstery should be adjusted to provide support and comfort. See section "Seating comfort settings".

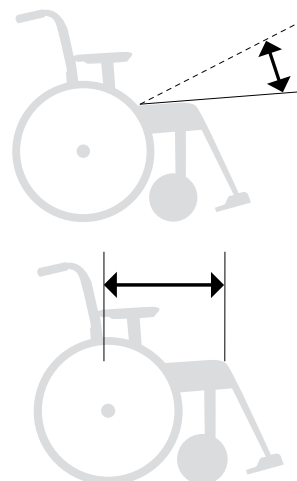

Front seat height can be adjusted using:

- Front fork attachment, adjustable in height and angle.
- Changing the position of the castor wheel in the front fork.
- Change of front fork
- Change of castor wheel
- Change of front fork attachment



Tipping risk. Inactivated anti-tips will increase the risk of injury. Activate the anti-tips to avoid the risk of tipping.

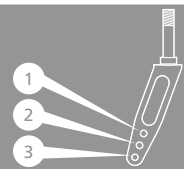

Installation instructions can be found in the sections "Height adjustment front fork attachment", "Angle adjustment front fork attachment", "Removing/mounting front fork" and "Removing/installing castor wheels".

Front seat height table 57 mm castor hub													
													
Castor wheel position													
		Front fork extra short (steel)			Front fork short (steel)			Front fork medium (steel)			Front fork long (steel)		
Castor wheel		1	2	3	1	2	3	1	2	3	1	2	3
Low front fork attachment	4"*	320-360	335-380	355-400									
	5"				360-400	375-415	390-430						
Standard/Widened front fork attachment	5"				375-415	390-430	405-445	430-460	450-480	460-490			
	6"					400-440	415-455	450-470	460-490	470-500			
	6½"					410-450	425-465	460-480	470-490	480-510	505-525	515-535	525-555
	7"								475-495	485-515			530-560
	8" **								480-510	490-520		525-545	535-565

* Max user weight 100 kg.

For correct adjustment of the front fork attachment: Max backwards angle 6 cm higher front than rear (9°), max forward angle 2 cm lower front than rear (3°).

** Works in balancing 4-6 with 3° backward angle and Std leg support. Make sure that the front fork/castor wheel can rotate freely without hitting the wheelchair or the user. For castor wheels 8x2", use fork Transit (gives seat height 47-51 cm).

12. Advanced settings, customization

Front seat height table 45 mm castor hub

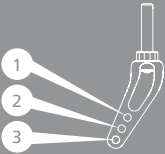
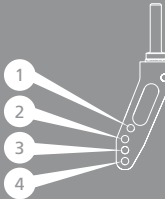
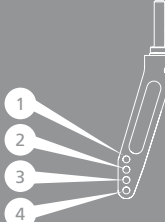
													
		Castor wheel position											
		Front fork XS (alu)			Front fork S (steel)				Front fork M (steel)				
	Rear wheel	1	2	3	1	2	3	4	1	2	3	4	
Low widened	4" *	320-360	335-375	345-385									
	5"				345-385								
H100	5"				375-415	385-425	395-435	410-450	425-465	435-475	445-485	460-500	
	6"					395-435	410-450	425-465	435-475	445-485	460-500	475-515	
	8" **							445-485	460-500	475-515	495-525	495-535	
H142	8"								460-540	475-555	485-565	495-575	

Dimensions in millimeter.

* Max user weight 100 kg.

For correct adjustment of the front fork attachment: Max backwards angle 6 cm higher front than rear (9°), max forward angle 2 cm lower front than rear (3°).

More combinations than above stated might be possible.

** Works in balancing 4-6 with 3° backward angle and Std leg support. Make sure that the front fork/caster wheel can rotate freely without hitting the wheelchair or the user.

12. Advanced settings, customization

Rear seat height can be adjusted using:

- The position of the rear wheel (camber washer) in the gable.
- Camber washer's twist in the gable.
- Change of rear wheels



Tipping risk. Inactivated anti-tips will increase the risk of injury. Activate the anti-tips to avoid the risk of tipping.

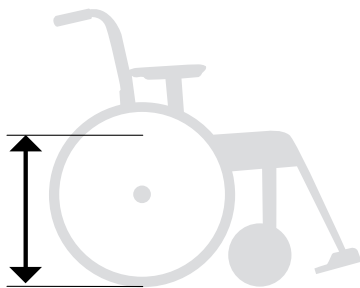

Seat height

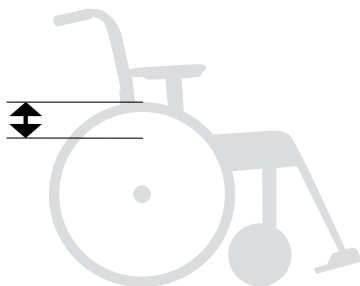

Distance seat-rear wheel

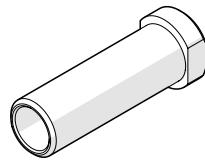

Rear seat height table hub C5

	Rear wheel	Seat height cm	Distance cm seat-rear wheel
Position A	20"	46	4.5
	22"	48.5	7.0
	24"	51	9.5
	26"	53,5	12
Position B	20"	44	6.5
	22"	46.5	9.0
	24"	49	11.5
	26"	51,5	14
Position C	20"	42	8.5
	22"	44.5	11.0
	24"	47	13.5
	26"	49,5	16
Position D	20"	40	10.5
	22"	42.5	13
	24"	45	15.5
	26"	47,5	18
Position E	20"	38	12.5
	22"	40.5	15
	24"	43	17.5
	26"	45,5	20
Position F	20"	36	14.5
	22"	38.5	17
	24"	41	19.5
	26"	43,5	22
Position G	20"	34	16.5
	22"	36.5	19
	24"	39	21.5
	26"	41,5	24
Position H	20"	32	18.5
	22"	34.5	21
	24"	37	23.5
	26"	39,5	26

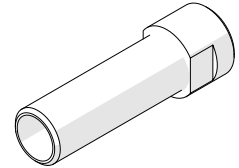

Rear seat height table hub C6

	Rear wheel	Seat height cm	Distance cm seat-rear wheel
Position A	20"	46	4.5
	22"	48.5	7.0
	24"	51	9.5
	25"	52,5	11
	26"	53,5	12
Position B	20"	44	6.5
	22"	46.5	9.0
	24"	49	11.5
	25" Maxx	50,5	13
Position C	20"	42	8.5
	22"	44.5	11.0
	24"	47	13.5
	25" Maxx	48,5	15
Position D	20"	40	10.5
	22"	42.5	13
	24"	45	15.5
	25" Maxx	46,5	17
Position E	20"	38	12.5
	22"	40.5	15
	24"	43	17.5
	25" Maxx	44,5	19
Position F	20"	36	14.5
	22"	38.5	17
	24"	41	19.5
	25" Maxx	42,5	21
Position G	20"	34	16.5
	22"	36.5	19
	24"	39	21.5
	25" Maxx	40,5	23
Position H	20"	32	18.5
	22"	34.5	21
	24"	37	23.5
	25" Maxx	38,5	25

12. Advanced settings, customization

Height adjustment front fork attachment

Loosen the screws (A and B). Set the desired seat height by measuring from the floor to the top of the seat post (push down the post in the cup when measuring) and tighten the screws on one of the front fork attachments. Use the bar markings as a reference for height adjustment of the opposite side. Tighten the other attachment. Check and adjust so that the attachments are vertical (see section "Angle adjustment of front fork attachment"). Fine-tune the height of the front fork attachments so that both wheels are on the floor.



Tipping risk. Inactivated anti-tips will increase the risk of injury. Activate the anti-tips to avoid the risk of tipping.

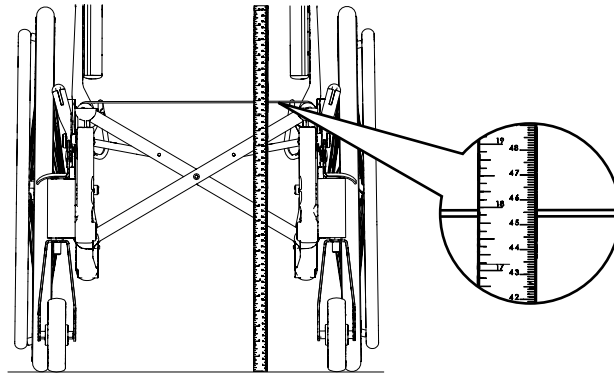
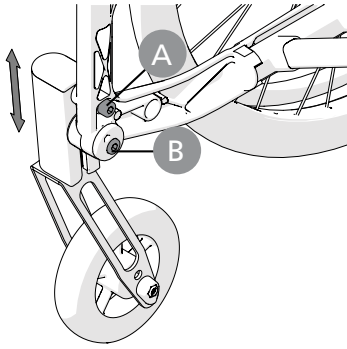

6 mm



20 Nm

Angle setting front fork attachment

Correct angle setting is important for the wheelchair's driving characteristics.

Loosen the retaining screw (A) about 2 turns so that the shaft (C) moves freely inside the sleeve.

Insert the Allen key into the hole (B) and turn until the attachment is vertical. Always start from a position so that the wheel moves forward in rotation (D).

Push in the sleeve and hold in the correct position while tightening the retaining screw.



Tipping risk. Inactivated anti-tips will increase the risk of injury. Activate the anti-tips to avoid the risk of tipping.



Aim for something vertical, such as door post, table legs when setting.

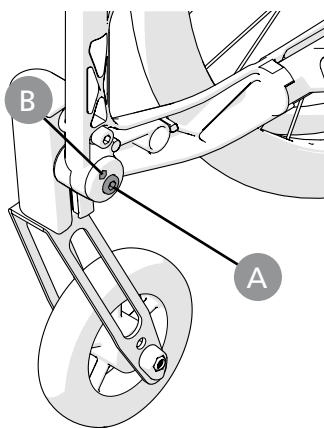

6 mm



20Nm

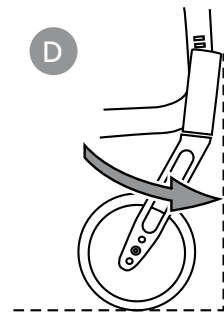
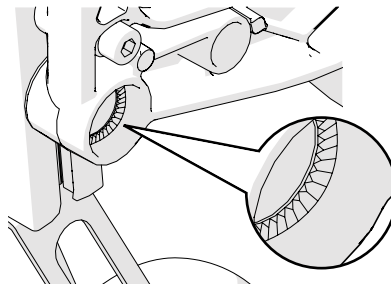
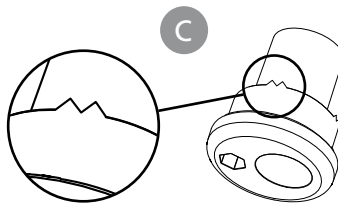

12. Advanced settings, customization

Removing/mounting front fork

- Remove cover (A) and loosen lock nut (B). Pull out the front axle and move the beveled washer (C) and the ball bearing to the new axle.
- Mount the washers and ball bearings in the front fork attachment as illustrated. The washer (C) is placed with a beveled side against the axle. Spring washer (D) at the top under the lock nut.
- Gently tighten the lock nut until the front axle spins with some inertia and then loosen about 1/2 turn. The spring washer then has the correct tension, which reduces the risk that the castor wheel starts to "wobble".
- Fit the cover.

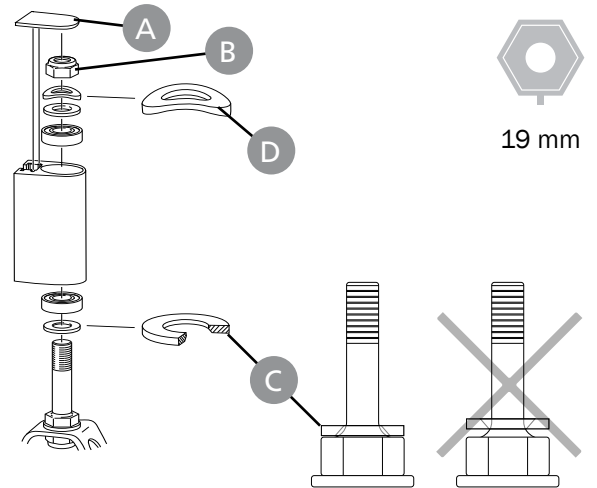

Removing/mounting castor wheels

Loosen screw, nut and spacer and mount the wheel in the appropriate position.



Tipping risk. Inactivated anti-tips will increase the risk of injury. Activate the anti-tips to avoid the risk of tipping.

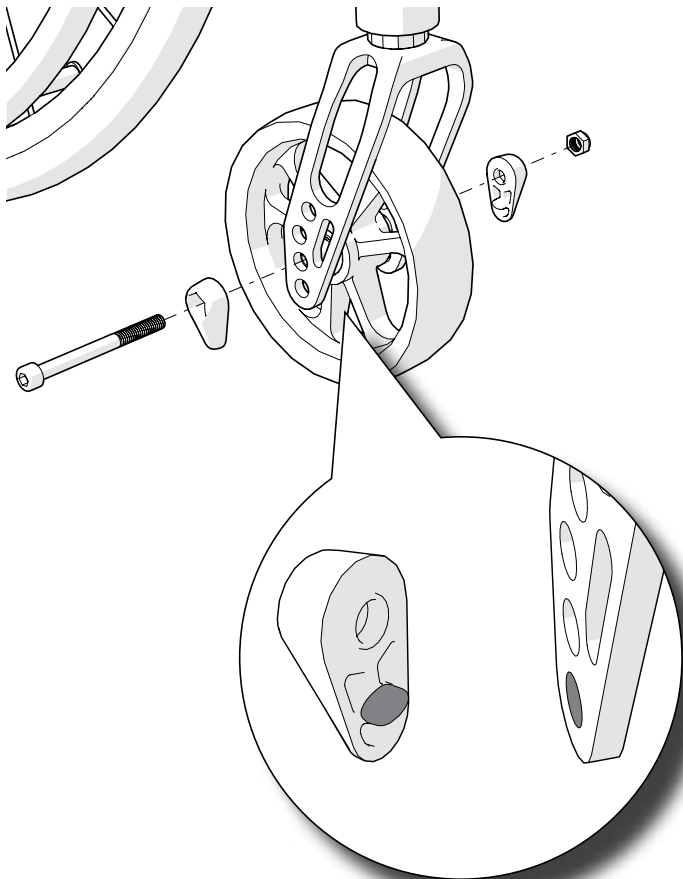

5 mm

Hub width 45 mm

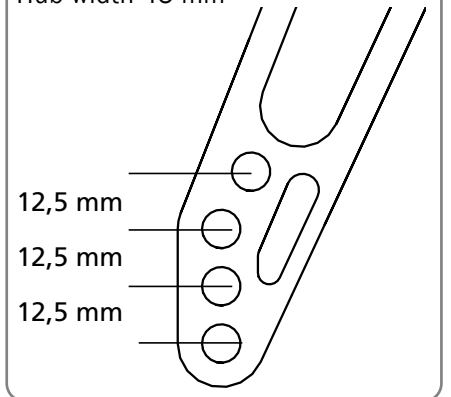

Hub width 57 mm

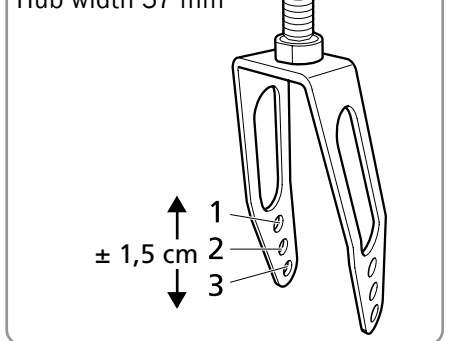

12. Advanced settings, customization

Change rear wheel position

1. Remove the rear wheel
2. Loosen the nut.
3. Take the assembly apart with the washers and mount in the desired position (see table in section "Rear seat height table").



Tipping risk. Inactivated anti-tips will increase the risk of injury. Activate the anti-tips to avoid the risk of tipping.

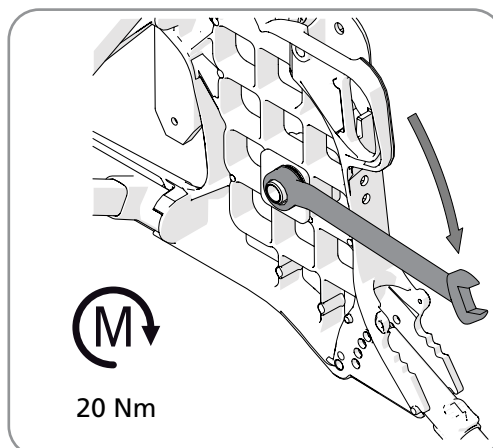
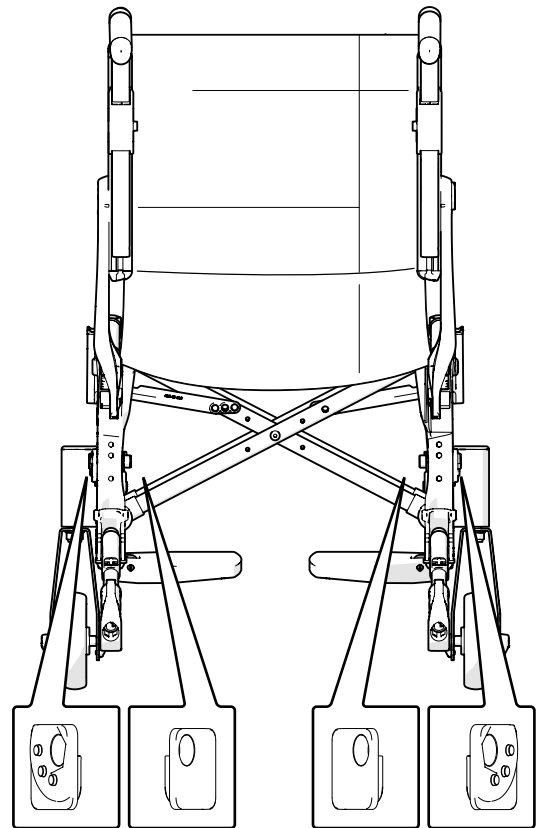
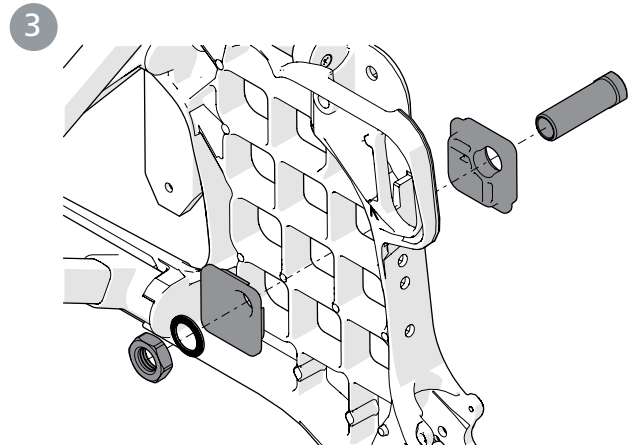
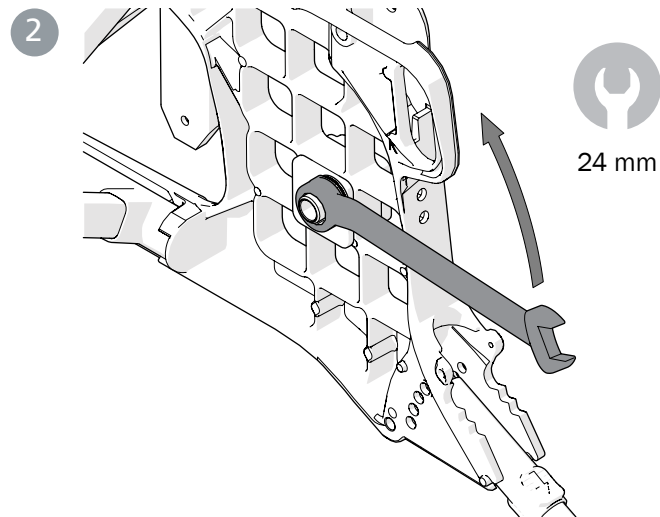
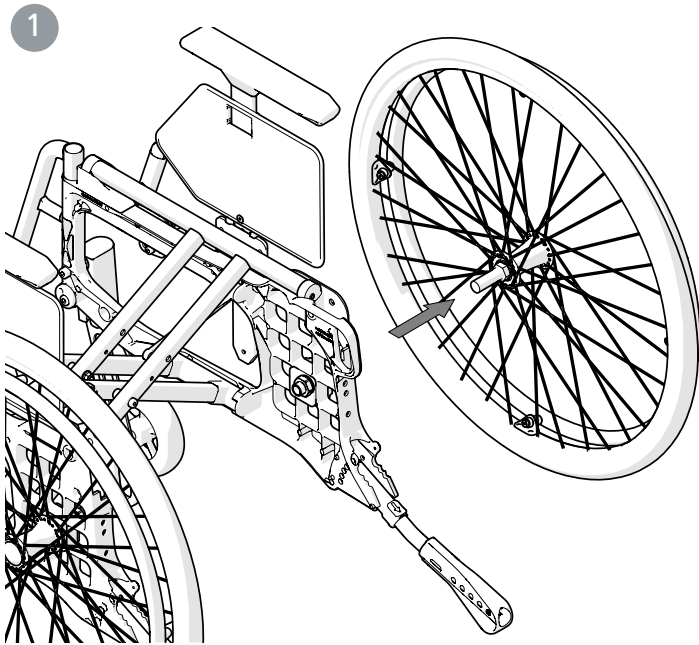

12. Advanced settings, customization

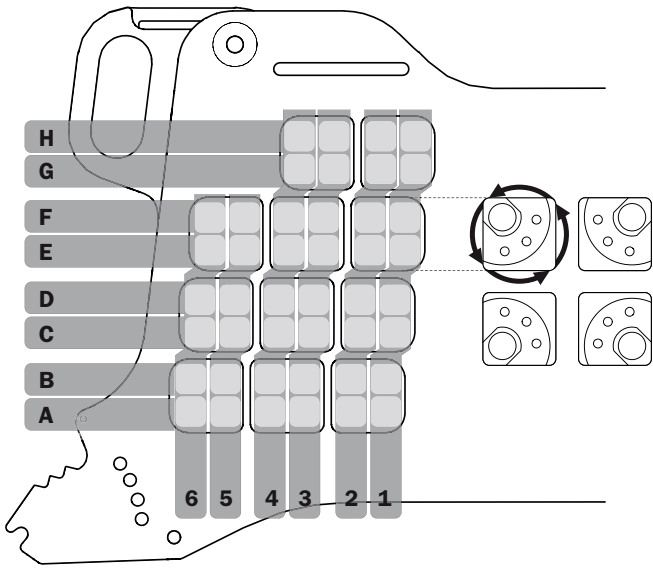

Fitting 0° Camber

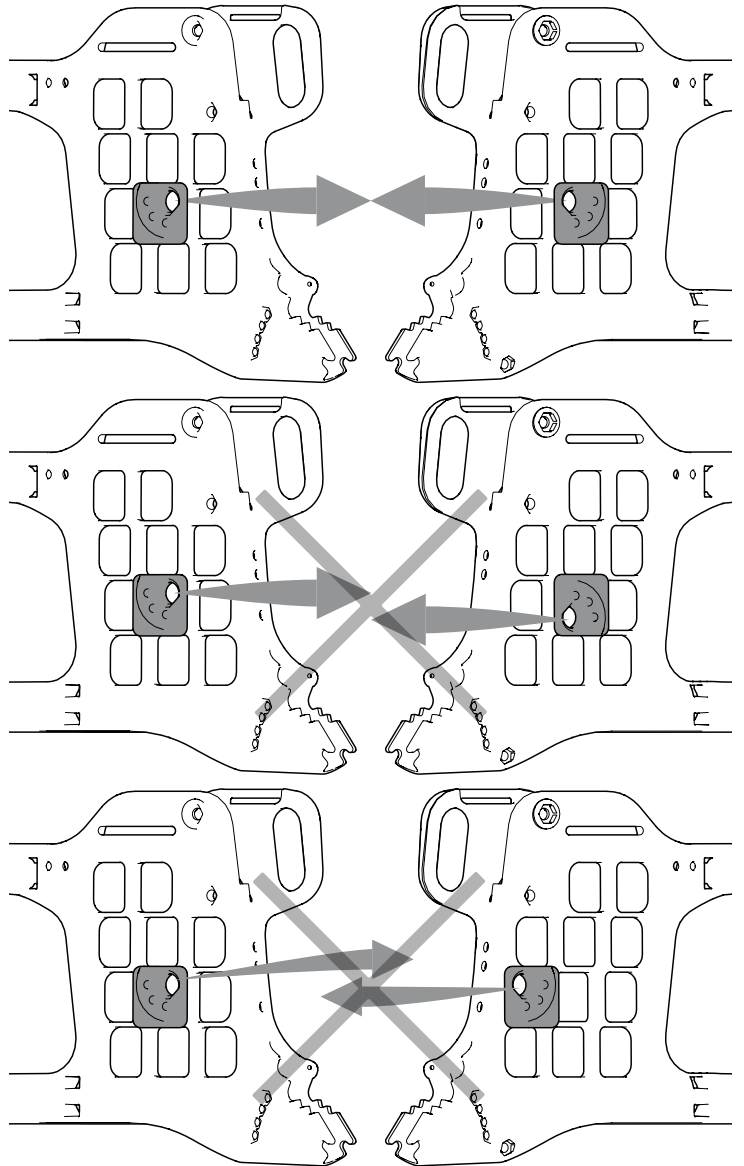
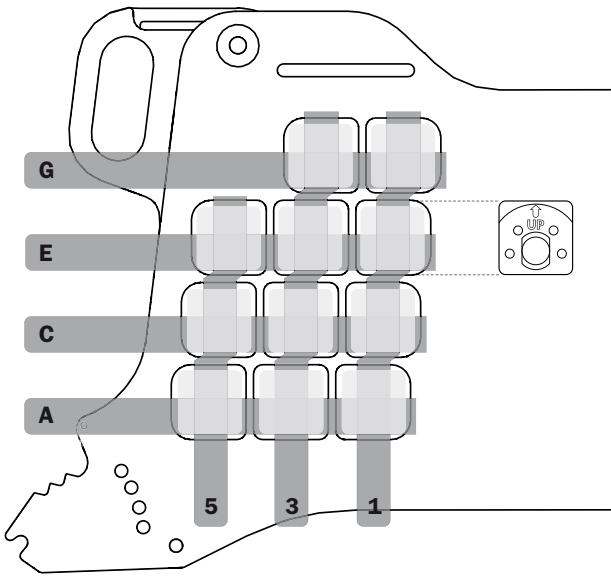

When attaching the rear wheels, make sure that the quick-release button fully returns. Test by pulling the wheel. Risk of injury.

12. Advanced settings, customization

Change rear wheel position, attendant brake

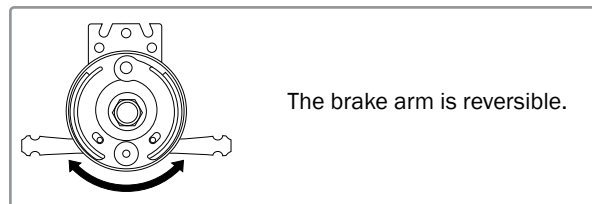
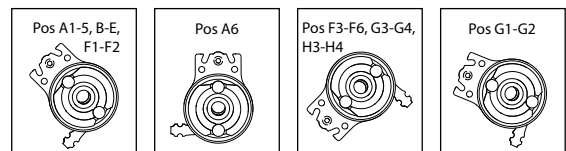
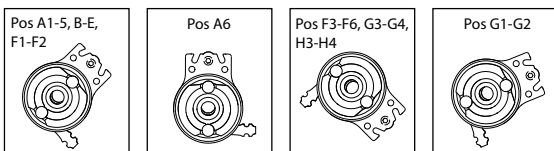
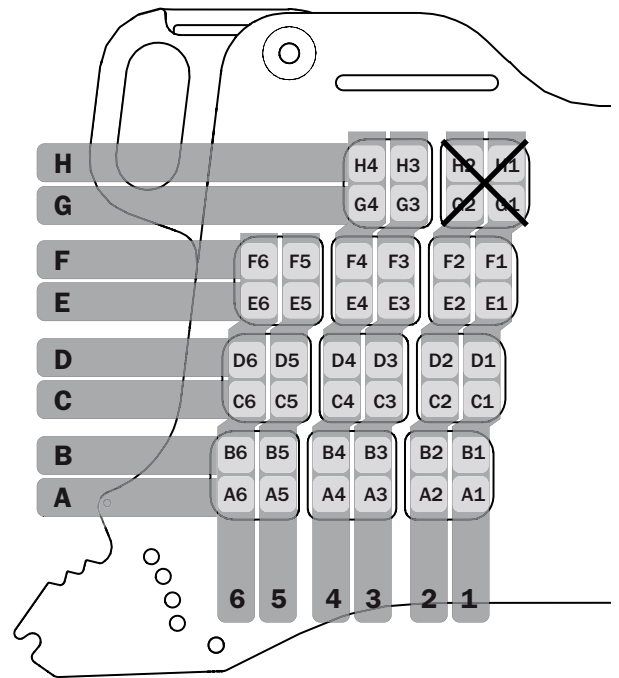
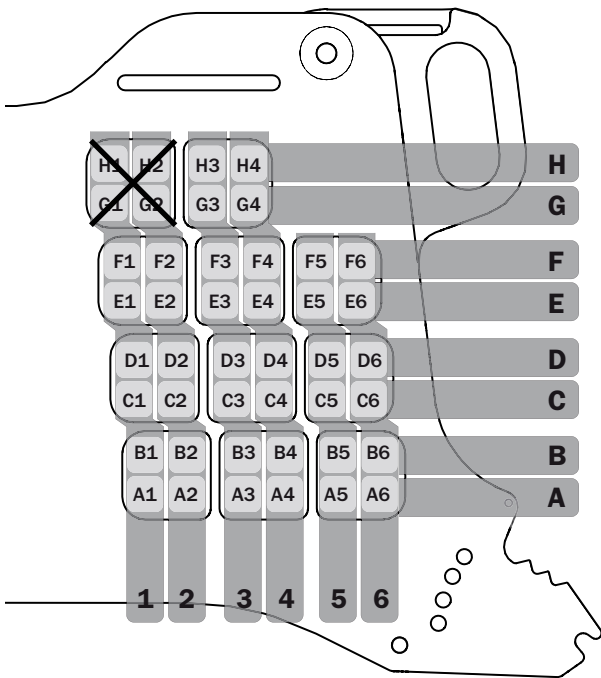
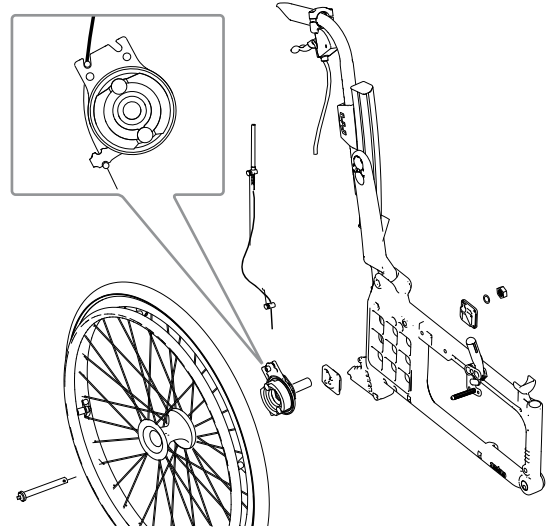
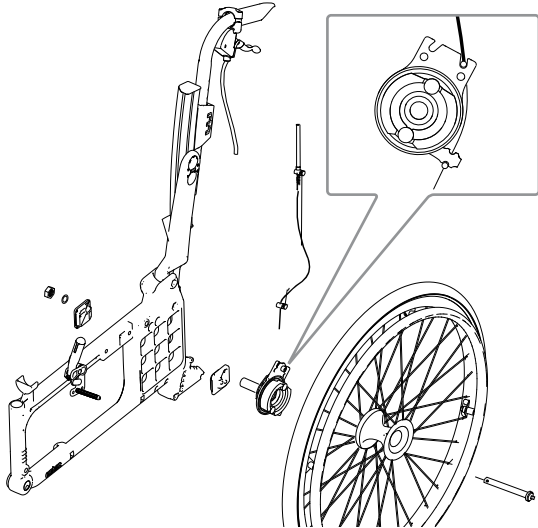

When adjusting the brake, loosen the nut (A) and adjust the brake by screwing (B) up/down.
When the brake is tight enough tighten the nut (A). This adjustment should be made when the brake does not work satisfactorily.

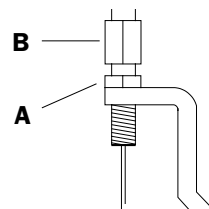

12. Advanced settings, customization

Adjust the back support angle, 3A

The angle of the back support is continuously adjustable (see "The chair's possibilities").

1. Loosen the nut.
2. Adjust the back angle. Use the bar markings or count the number of "clicks" to get the same back angle on the right and left sides respectively. The click positions have 3° intervals and are only

for simplifying the setting, the back angle can therefore also be adjusted between the click positions.

3. Tighten the nut.



Tipping risk. Inactivated anti-tips will increase the risk of injury. Activate the anti-tips to avoid the risk of tipping.

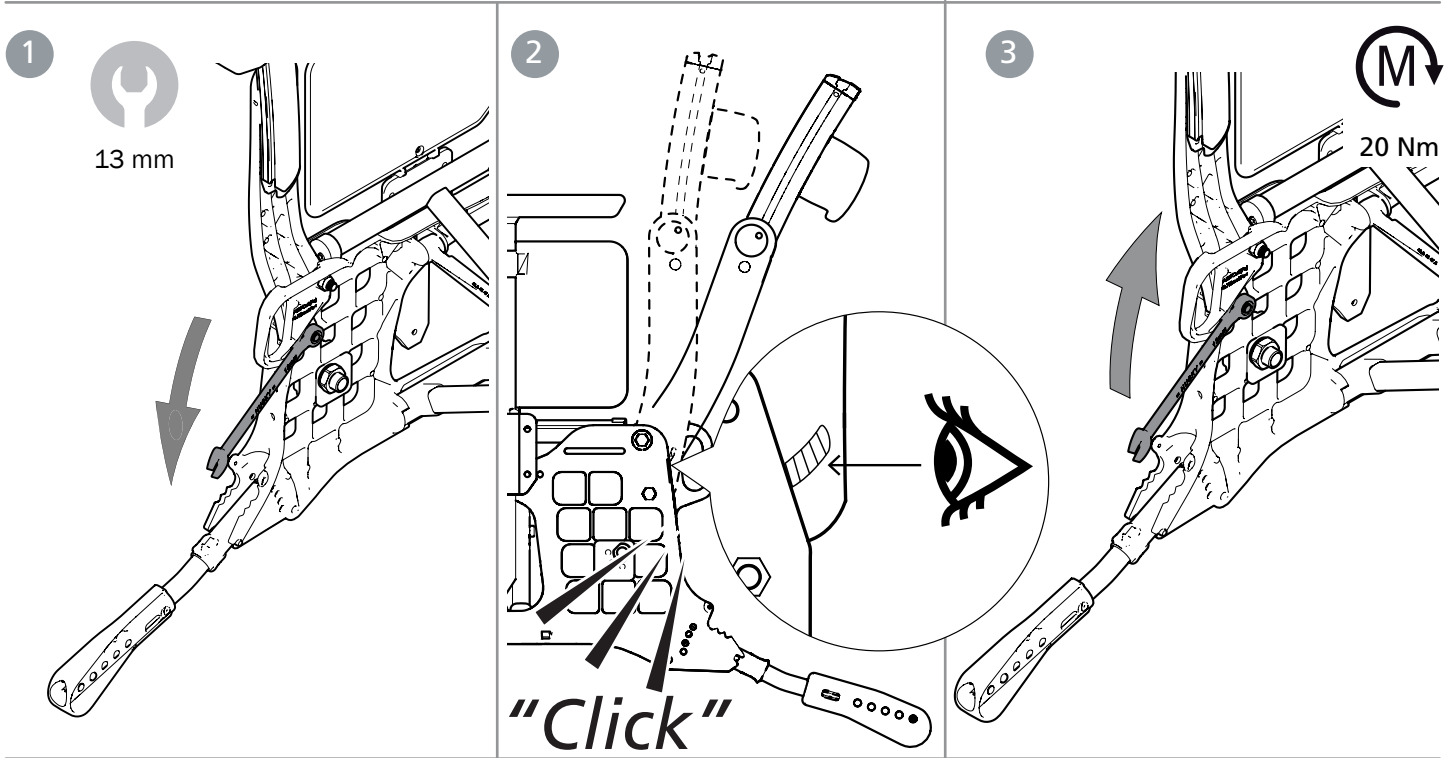

Adjust the back support height and lumbar angle, 3A

The back height is adjustable (see "The chair's possibilities").

1. Loosen the locking screws (A) max 1 turn.
2. Adjust the back height using the scale and mark on the lower back rail. Tighten the locking screws max 1/2 turn.
3. Insert the Allen key into the eccentric sleeve locking screw and loosen this 1/2 turn. Move the Allen key to the eccentric sleeve's key grip and set the desired lumbar angle.
4. Tighten the locking screws.



Tipping risk. Inactivated anti-tips will increase the risk of injury. Activate the anti-tips to avoid the risk of tipping.

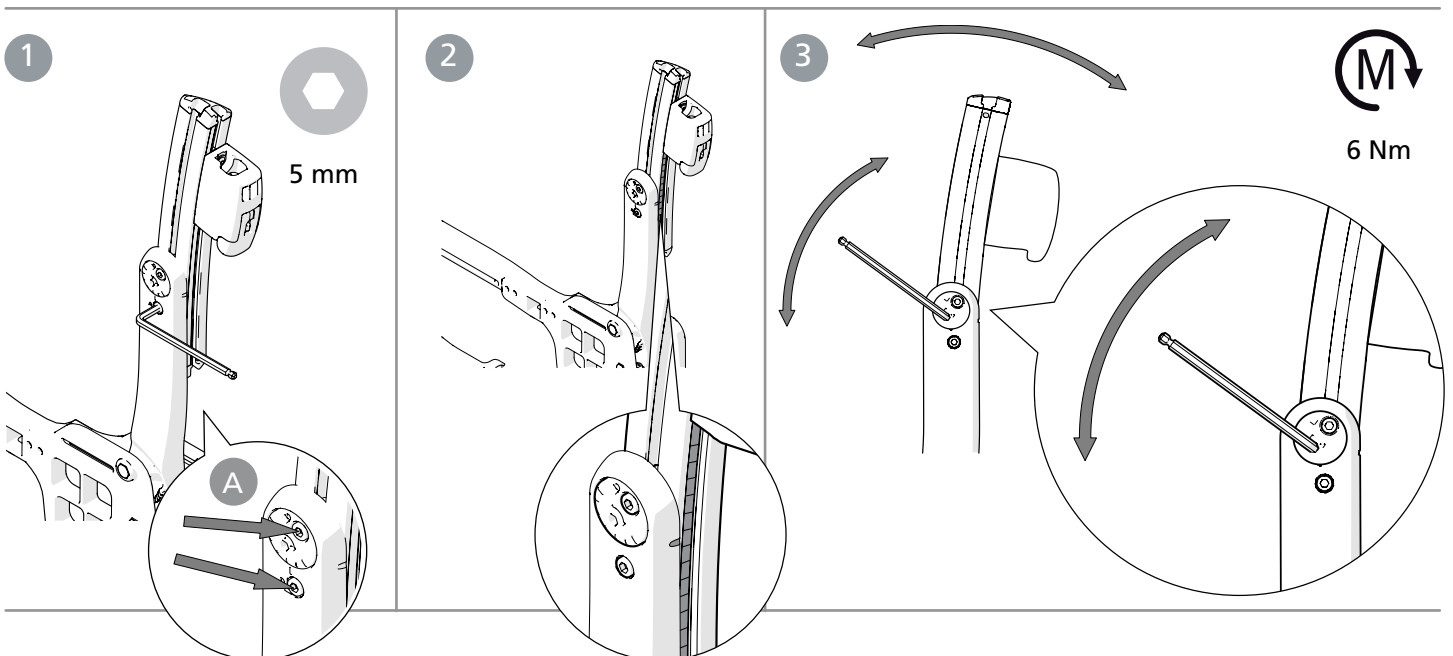

12. Advanced settings, customization

Adjust seat depth using lumbar angle, 3A

An extended seat depth is obtained by opening the back support angle (hip) and following with the lumbar angle.

1. Adjust the back angle (see section "Adjusting the back support angle 3A").
2. Adjust the lumbar angle using the eccentric sleeve to the desired back angle (see "Adjusting the back support height and lumbar angle, 3A").
3. If necessary, mount the seat extender (accessory).



Tipping risk. Inactivated anti-tips will increase the risk of injury. Activate the anti-tips to avoid the risk of tipping.

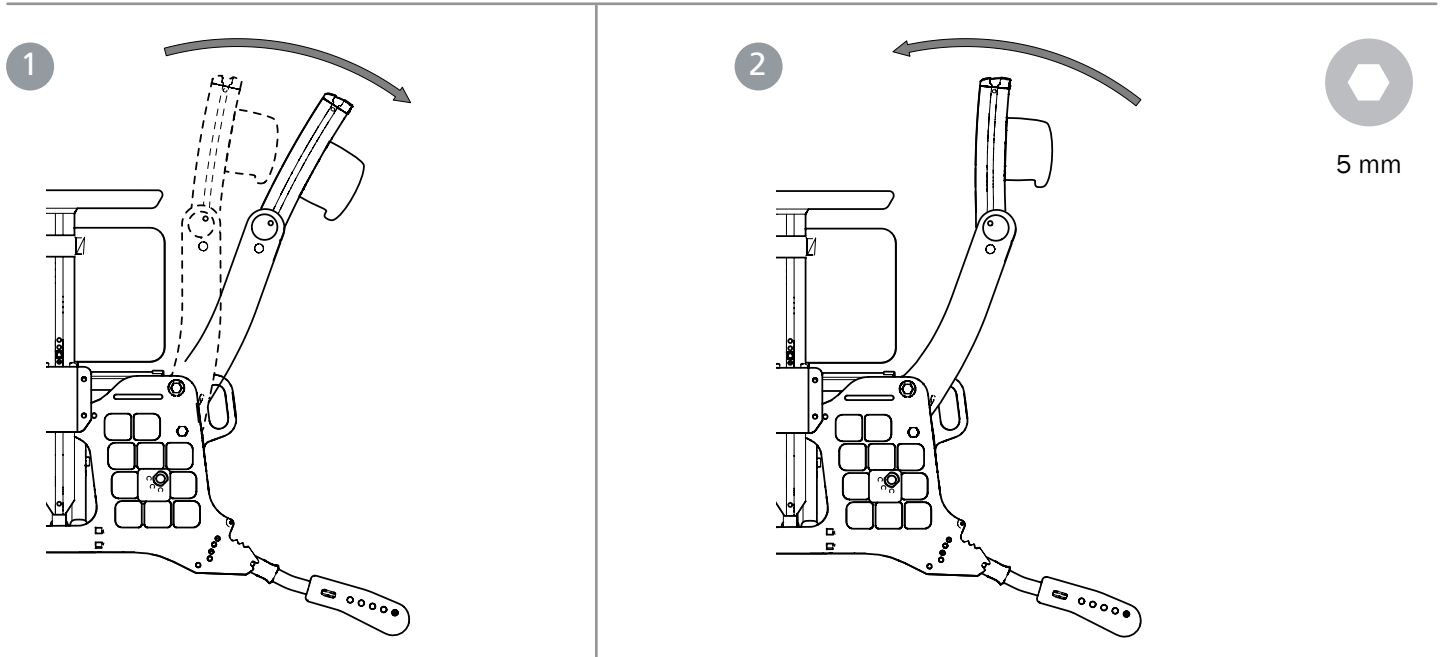

Mount the seat extender

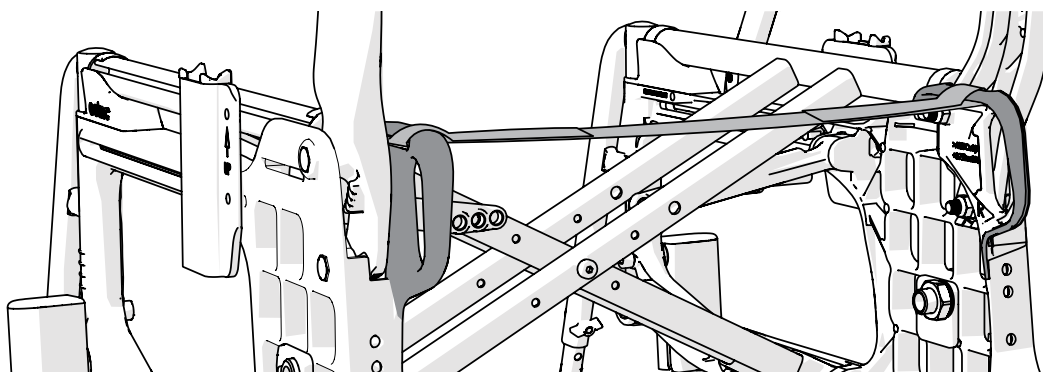
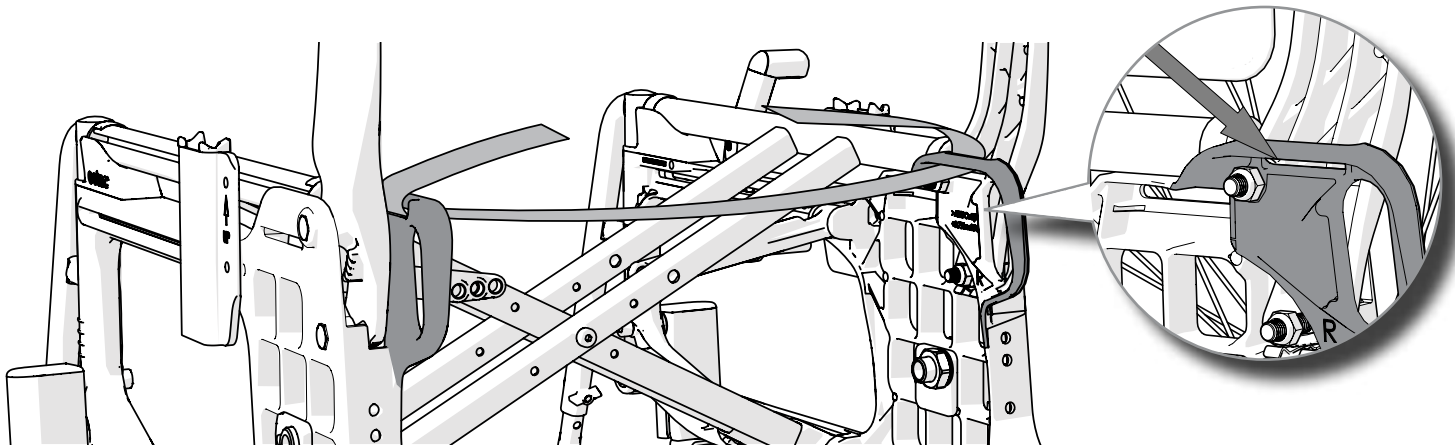

12. Advanced settings, customization

Adjust the back support height, 2B

The back height is adjustable (see “The chair’s possibilities”). Loosen the screws to adjust the back height. Tighten the screws.

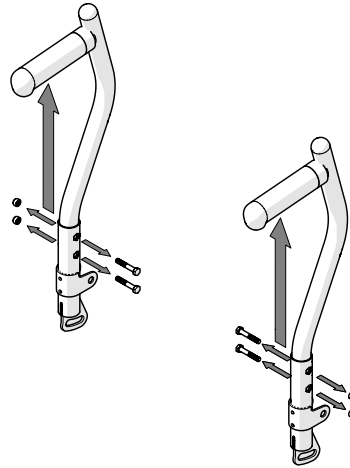

4 mm



8 mm



Tipping risk. Inactivated anti-tips will increase the risk of injury. Activate the anti-tips to avoid the risk of tipping.

Adjust the back angle, 2B

The angle of the back support is continuously adjustable (see “The chair’s possibilities”). The angle is adjusted by means of the nut on the inside of the rear wheel mounts.

- Loosen the nut for one of the back posts, set the desired angle and tighten.
- Adjust the other back post equally.

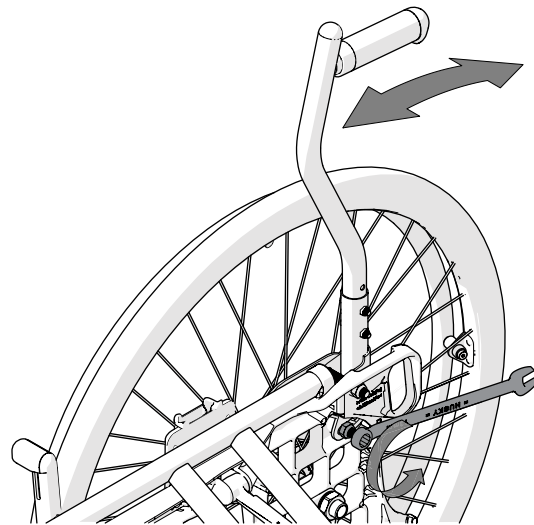

13 mm



Check that the angle is the same on both sides by comparing the distance between the back post and the arm support plate.



Tipping risk. Inactivated anti-tips will increase the risk of injury. Activate the anti-tips to avoid the risk of tipping.

13. Settings, readjustments

Brake, adjustment

The brake is continuously adjustable.

1. Loosen the screw a few turns.
2. Adjust the brake position
3. The brake pin must be approximately 15-20 mm from the tyre in the unbraked position.

4. Make sure the brake is straight in the groove. Tighten the screw by about 5 Nm. Test the brakes!
5. Make sure the nut locks on the inside.



The braking effect depends on the tyre pressure. The brake is a parking brake and should not be used as a driving brake.

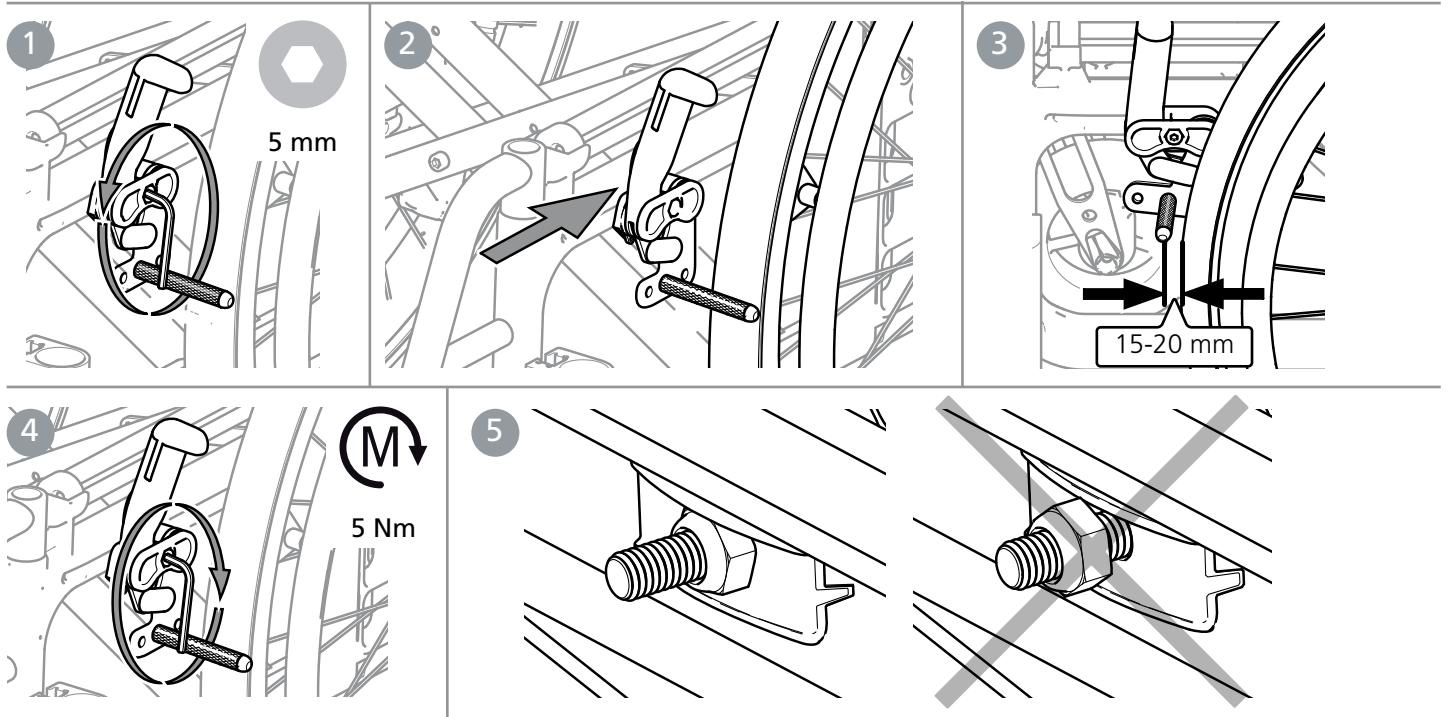

If the rear wheels are mounted in one of the front positions, leg supports that are folded aside can release locked brake. To avoid this, the brake lever should be adjusted so that it gets a "free position". Then the brake is released only when the brake lever is moved near the rear wheel.

1. Loosen the screw on the inside of the brake lever.
2. Remove the oval plate, turn it 180° (the spike on the inside of the plate should come in the upper hole).
3. Screw it in again.

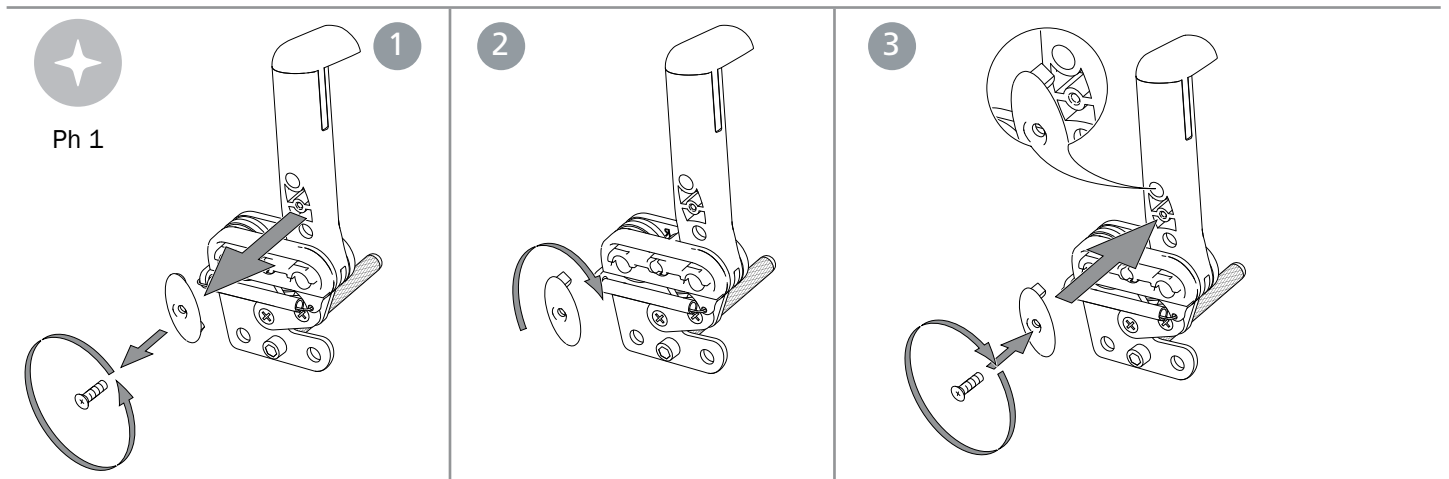

Adjusting the brake pin at certain rear wheel positions:

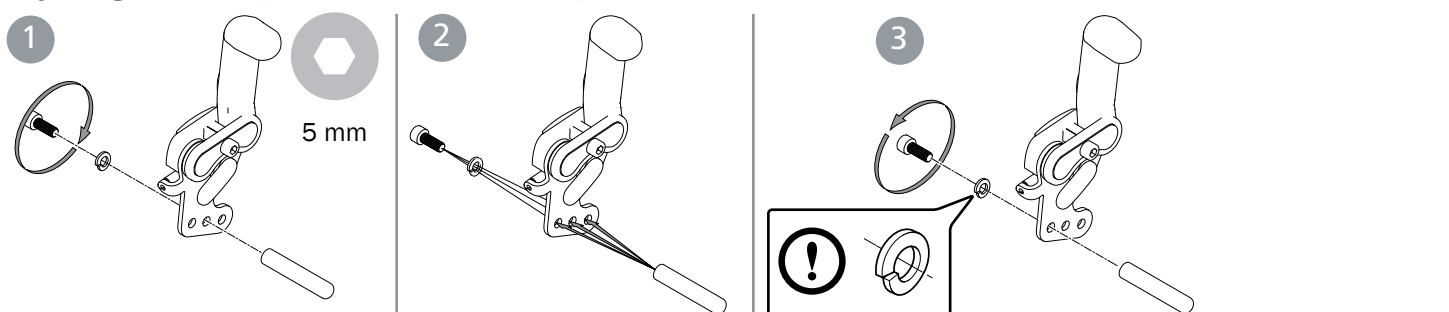

13. Settings, readjustments

Rear wheels with quick-release axle

The distance between the hub sleeve and the locking balls can be adjusted by adjusting the nut on the outside of the hub. The distance between the hub sleeve and the locking balls should be 0.2 to 1.2 mm.



When attaching the rear wheels, make sure that the quick-release button fully returns. Test by pulling the wheel. Risk of injury.

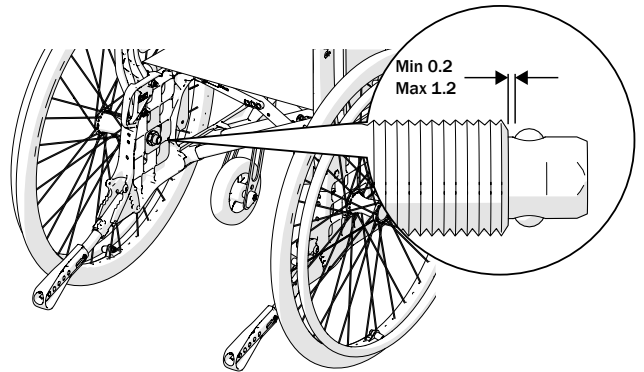
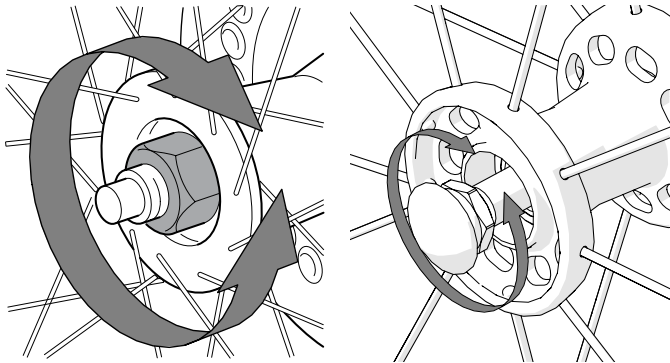

Leg supports, continuously elevating can be adjusted.

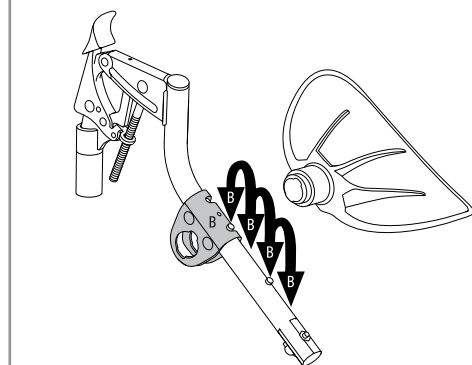
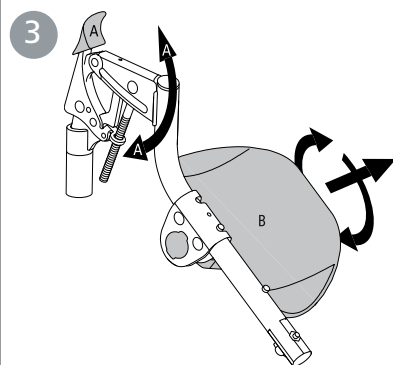
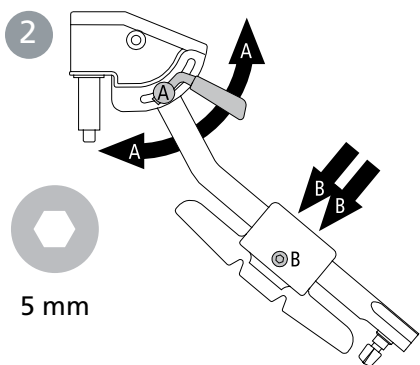
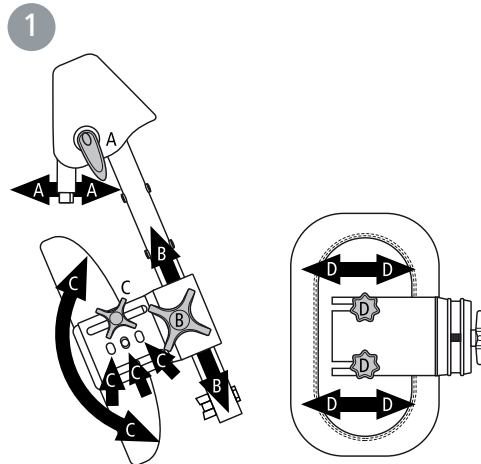
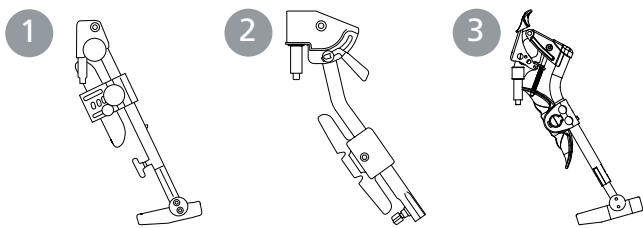

Amputee leg support can be adjusted.

Never sit on the amputee support.

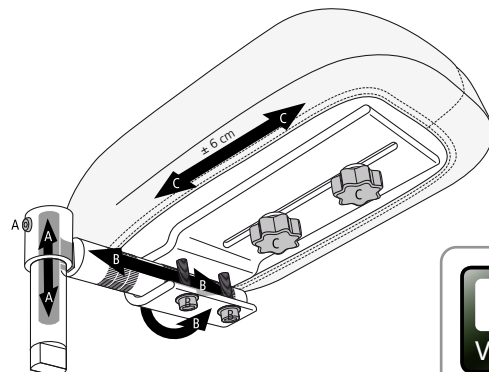
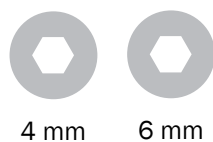

13. Settings, readjustments

The **anti-tip guards** are adjustable in height and angle and adjustable in length.



Tipping risk. Inactivated anti-tips will increase the risk of injury. Activate the anti-tips to avoid the risk of tipping.

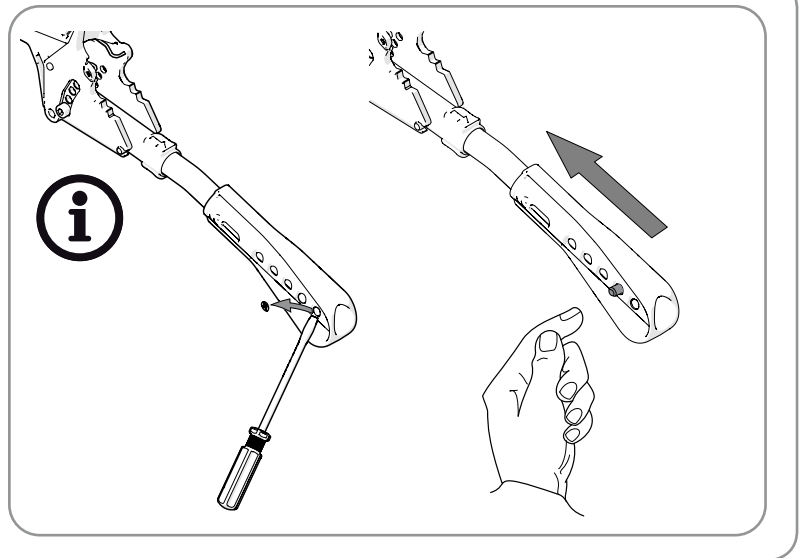
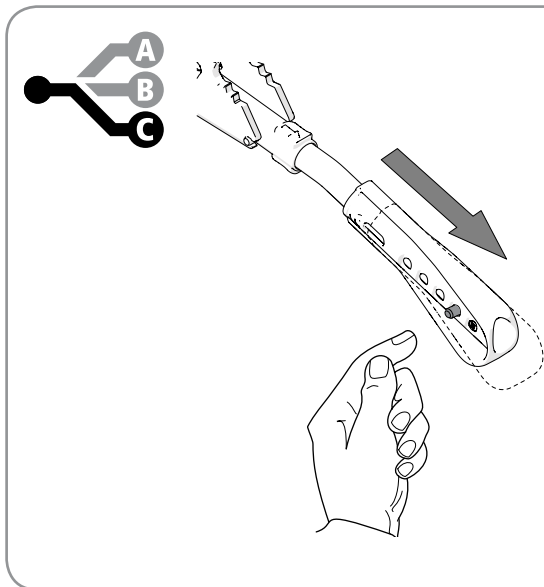
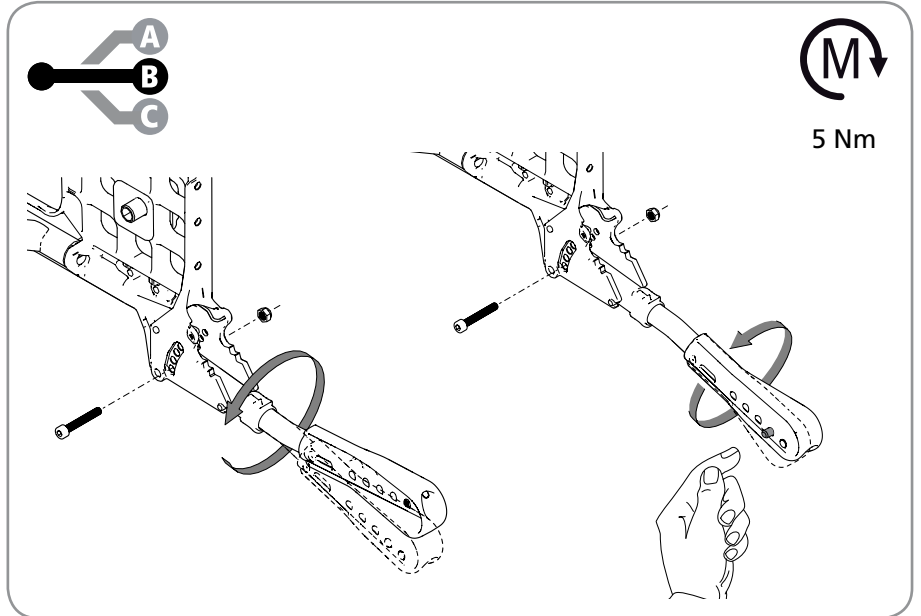
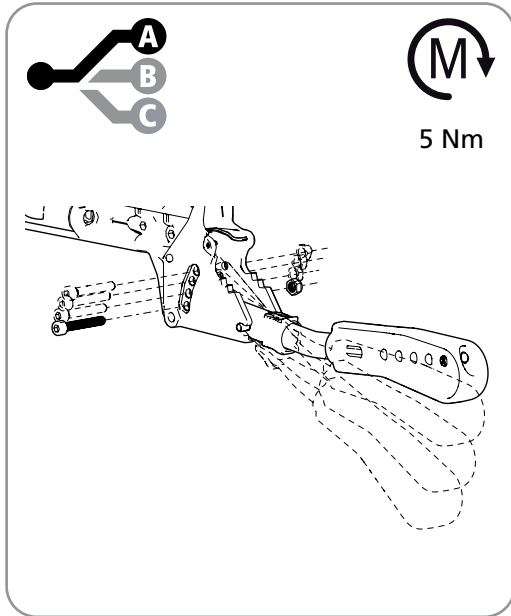

Handrims

The material of the handrims and the distance between the rear wheels and handrims affect the user's ability to grip.



Fingers can be injured if they get between the spokes. Spoke protection is available as a means to prevent injury.

Handrim distance

The handrim distance can be adjusted by moving the short spacer.

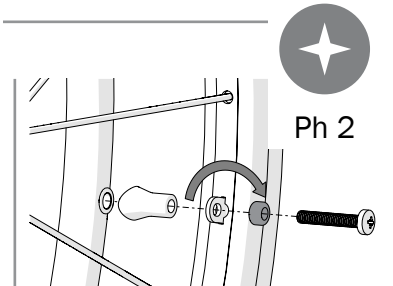
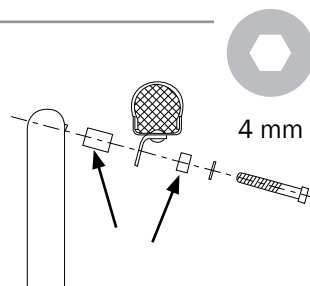

13. Settings, readjustments

The camber angle can be changed by replacing the washers between the hub sleeve and the nut (see also section “*Changing the rear wheel position*”).



When attaching the rear wheels, make sure that the quick-release button fully returns. Test by pulling the wheel. Risk of injury.

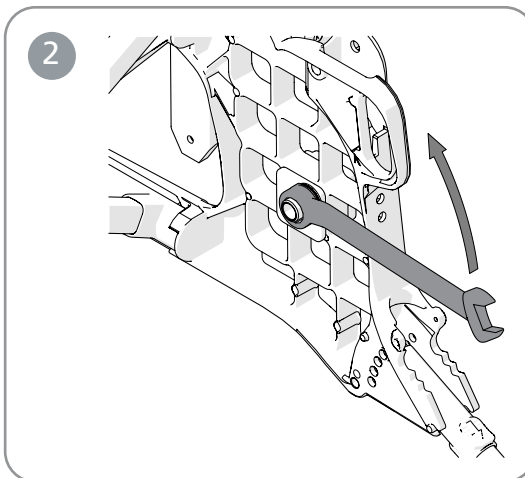
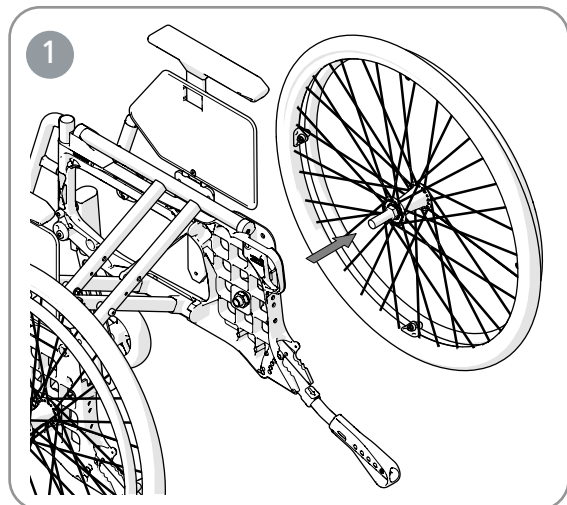

24 mm

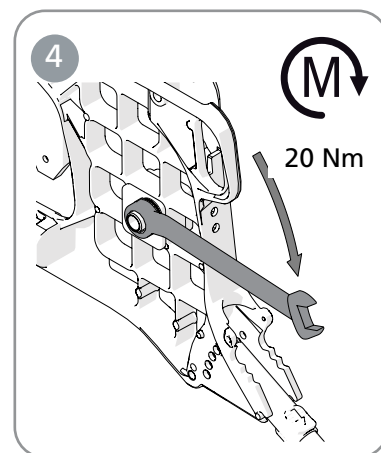
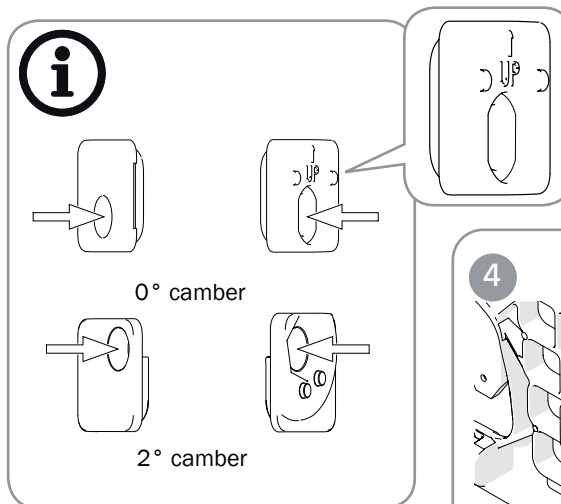
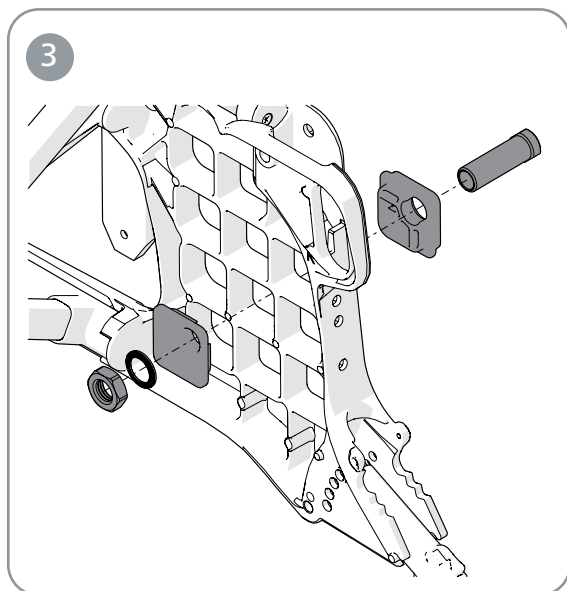

The centre of gravity/balance setting is adjusted by changing the position of the rear wheels.
- Move hubs/rear wheels forwards or backwards.



The centre of gravity also changes when changing seat angle and/or back angle.



Tipping risk. Inactivated anti-tips will increase the risk of injury. Activate the anti-tips to avoid the risk of tipping.



When attaching the rear wheels, make sure that the quick-release button fully returns. Test by pulling the wheel. Risk of injury.



24 mm

When the rear wheel position is moved forwards, the wheelchair becomes easier to drive and swivel, but the tendency to tilt backwards increases.

See section “*Changing the rear wheel position*”.

Also check the brakes, see section “*Brake, adjustment*”.

Toe-in, toe-out

Due to the design there is no need for a toe-in correction. Even when the rear wheel position is adjusted in height or centre of balance the rear wheel attachment makes sure that the adjustment of the toe-in is always correct.

13. Settings, readjustments

The arm support attachment can be mounted in two different positions in height, and two different positions in depth. In height position 1 the arm support height is adjustable from 18 to 26 cm and in position 2 (standard) from 24 to 31 cm. In depth the arm support is adjustable 14 mm.

The square nut determines both the height of the arm support and attaches the side plate:

- Loosen the screw holding the square nut.
- Slide the side plate up or down to the desired height.
- Tighten the nut again on the side plate.

If necessary, the right arm support can be mounted on the left side and vice versa.

Do not lift the wheelchair using the arm supports.



With 24" low pressure or solid tyres in pos. F1 & E1, the arm support side cover does not cover the front of the rear wheel.



With 24" rear wheels, the arm support attachment cannot be mounted in the rear position.

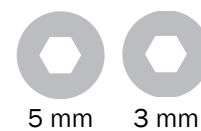

5 mm

3 mm

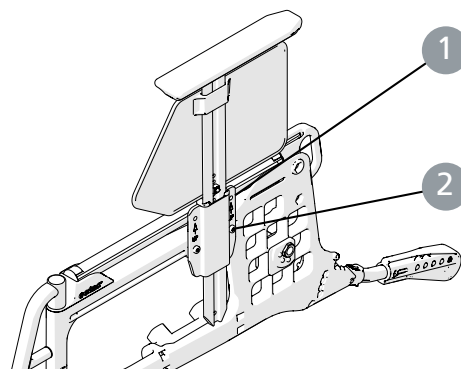

Mudguard can be adjusted in height and depth.

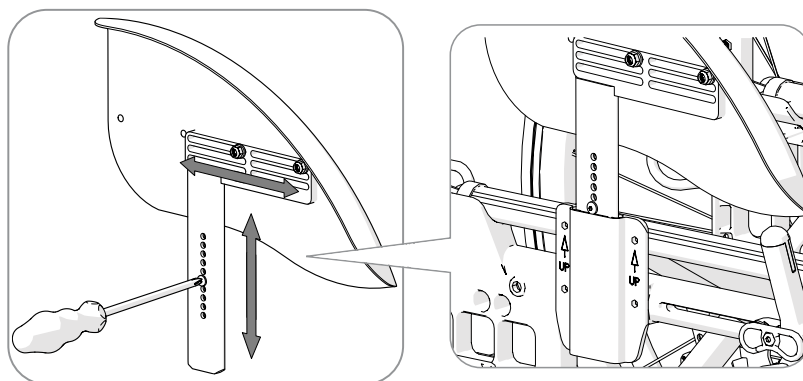

14. Settings, accessories

Installation instructions are always included with the accessories when delivered from Etac. Instructions are also available on our website www.etac.com

The seat cushion is cut to the set seat depth at the front or rear edge. Make sure that the cushion fits properly between the back posts with the rounded corners backwards when measuring the length. The cushion is a standard type and not intended for users with bed sores.

The cushion can be supplemented with a **comfort wedge**. It flattens out the front seat, which significantly improves seating comfort. Place the comfort wedge in the inner pocket of the pillow case on the underside of the cushion. The arrow on the comfort wedge should be facing up and pointing forwards.

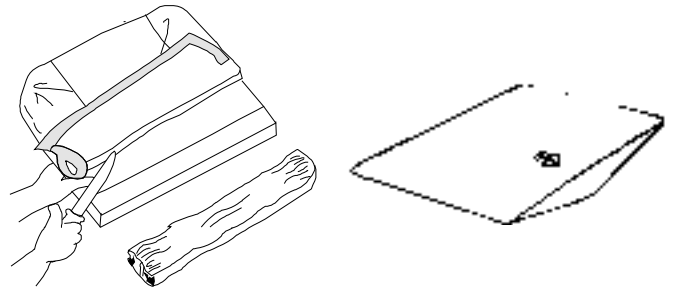

The positioning belt is two-piece, adjustable in length and has a snap-fit buckle. It is mounted in the groove just in front of the back support, above the rear wheel mount. The positioning belt is only for positioning in the wheelchair. It must not replace a seat belt in a car.



Ensure that the user does not slide forwards on the seat as the belt tightens the blood supply in the hip/waist region.

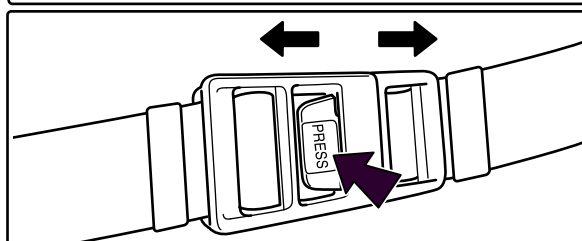
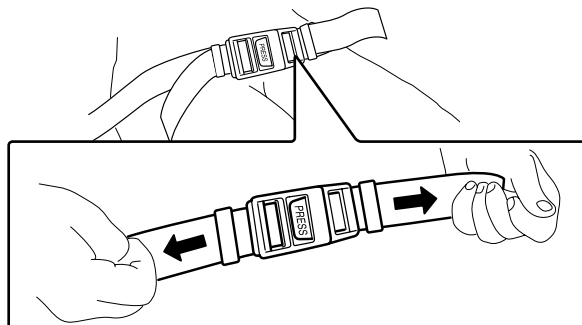
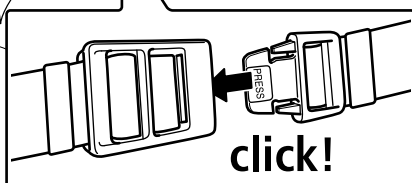
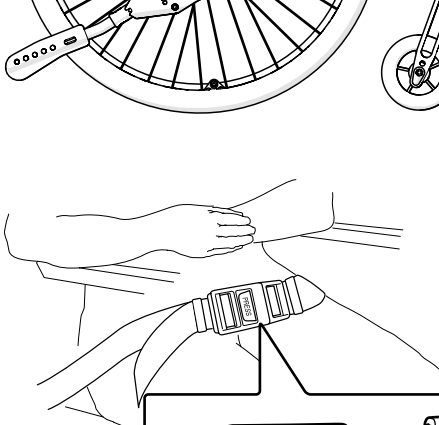
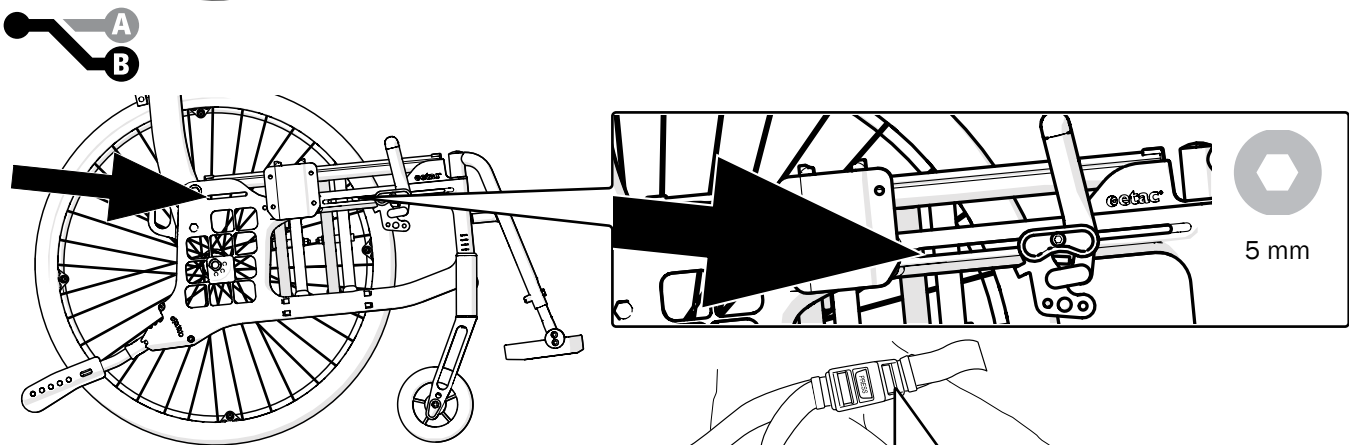
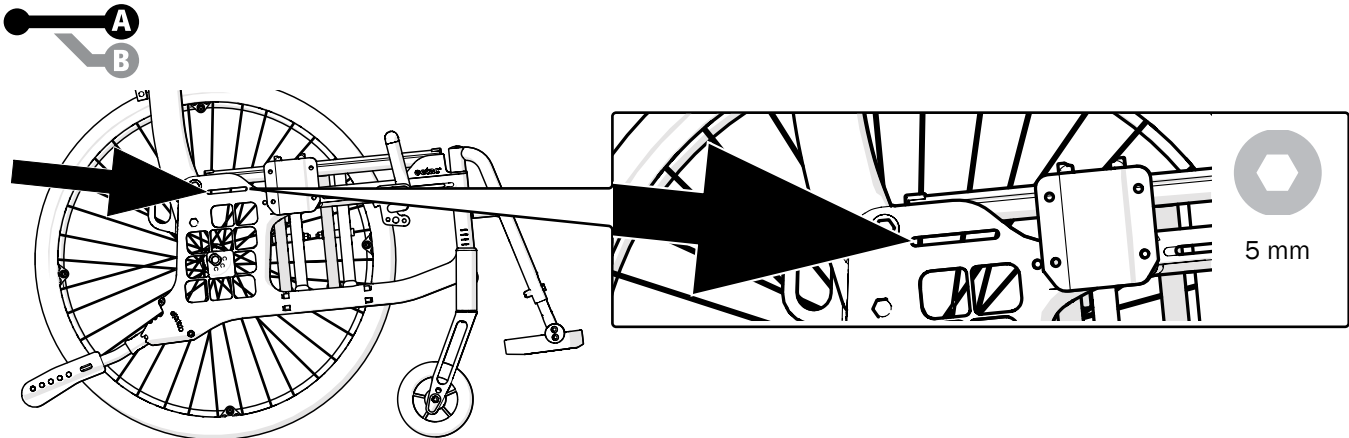

14. Settings, accessories

Head support is mounted on a separate head support mount or on a bow handle (optional). The head support is adjustable in height, depth, angle and sideways and detachable.



Before adjusting the head support, make sure that the user has a good sitting position and is seated firmly.



The center of balance might be altered when the user leans against the head support.

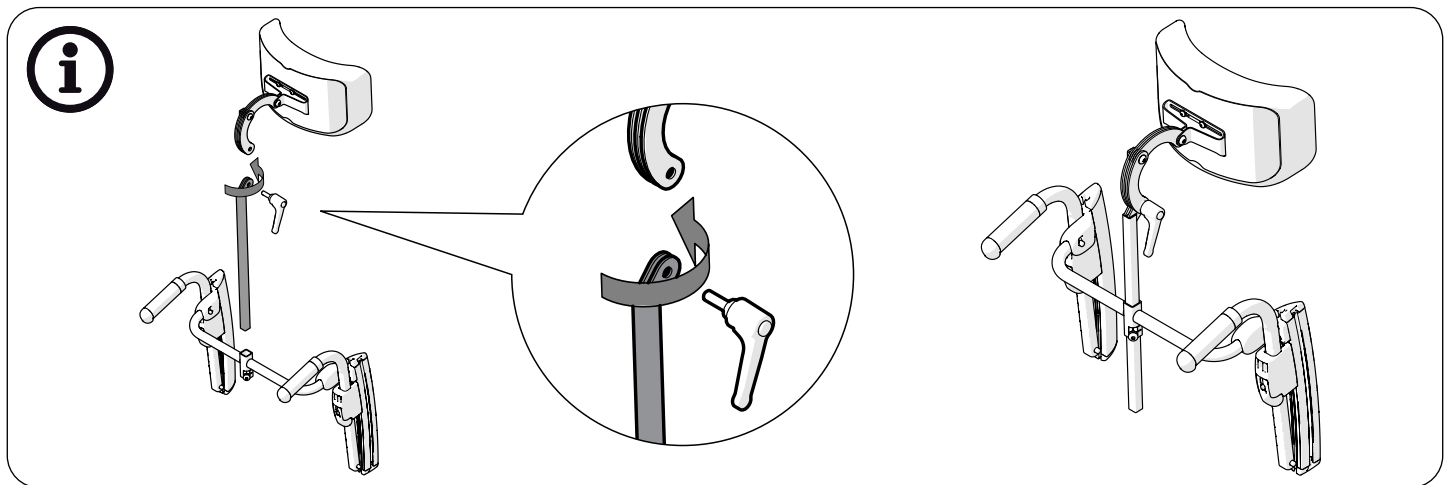
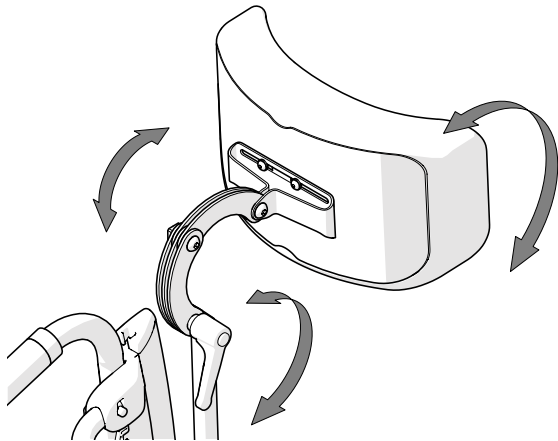
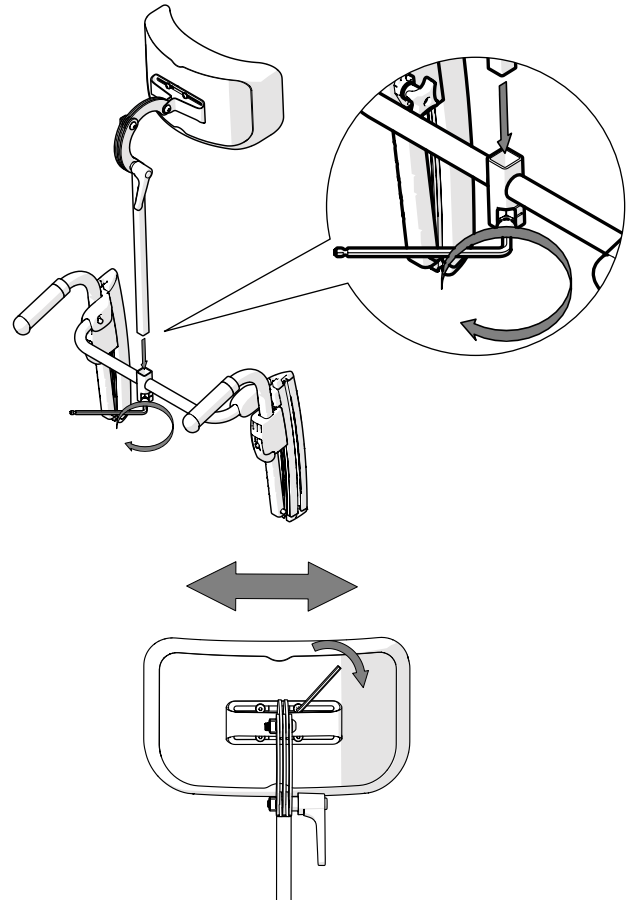

Head support mount is used for mounting head supports.



Do not lift the wheelchair by the head support mount. Risk of injury.

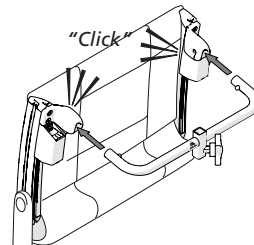

Crossbar is used when the back chassis needs to be reinforced.



Do not lift the wheelchair by the crossbar. Risk of injury.

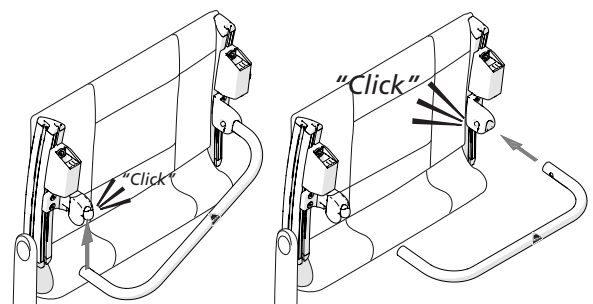

14. Settings, accessories

Attachment for chest harness

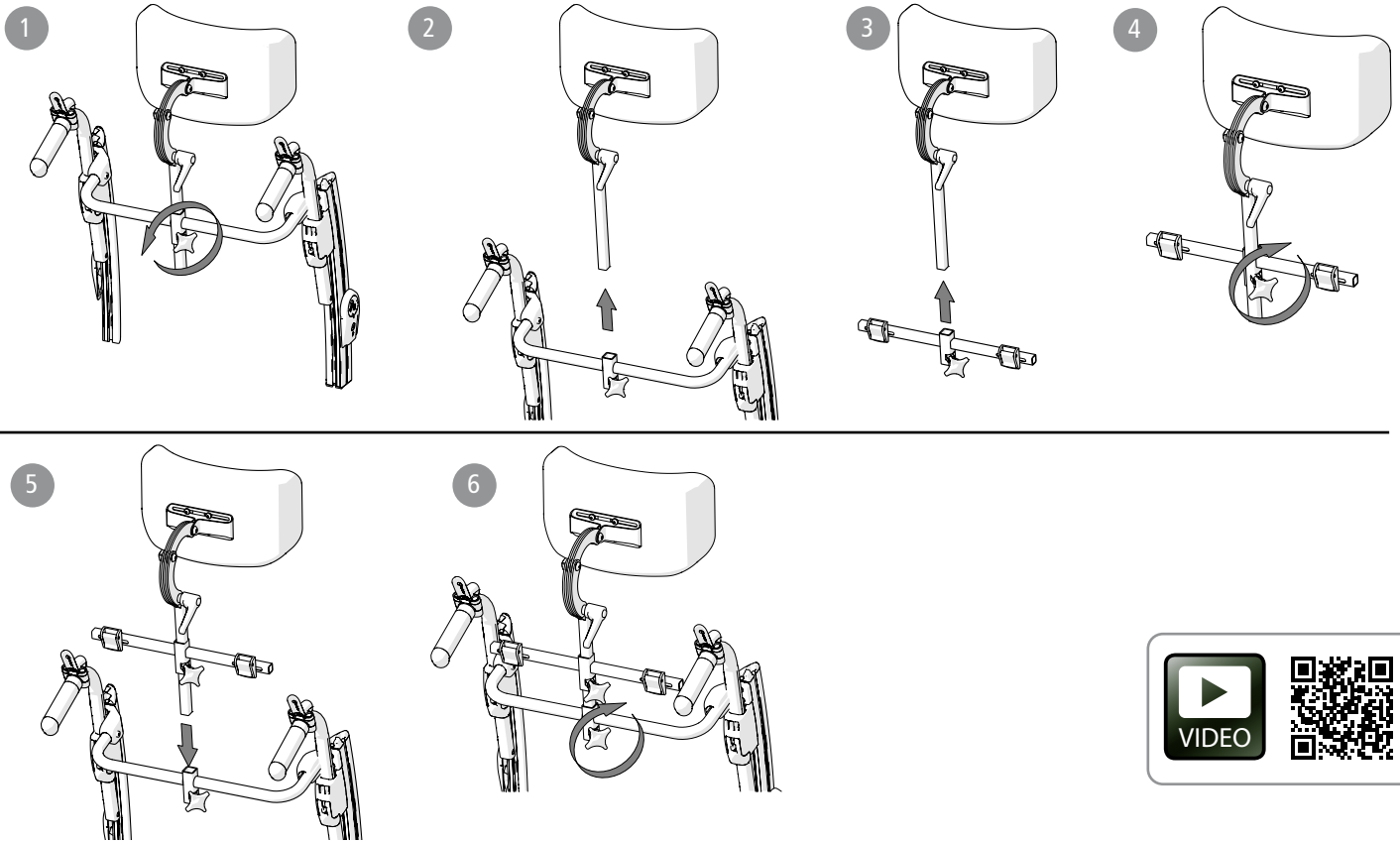

Attachment points for the chest harness

! Anterior trunk support shall only be used in combination with a positioning belt.

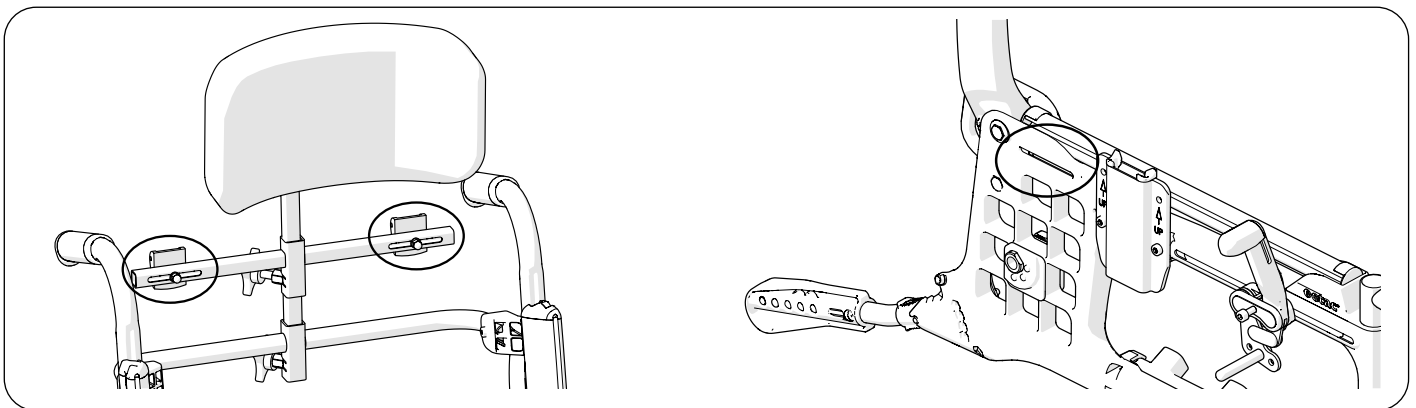

UK REP

Etac Ltd.

Unit 60, Hartlebury Trading Estate,
Hartlebury, Kidderminster,
Worcestershire, DY10 4JB
+44 121 561 2222

CH REP 

PromediTec SA

Ch. de Praz-Lau 1,
CH-1033 Cheseaux-sur-Lausanne
+41 (0)21 731 54 72



Etac Supply Center AB

Långgatan 12
SE-334 33 Anderstorp

 +46 371 58 73 00

 info@etac.com

 www.etac.com



75401

etac[®]
Creating Possibilities