



www.ascendor.at

PLATFORM STAIRLIFT
PANORAMA LIFT
VERTICAL PLATFORM LIFT
ENCLOSED ELEVATOR

ascendor[®]
LIFTTECHNIK

PLATFORM STAIRLIFT „STRAIGHT“



EASY HOME OPERATING MANUAL

+ PLATFORM STAIRLIFT



My ASCENDOR-Dealer:

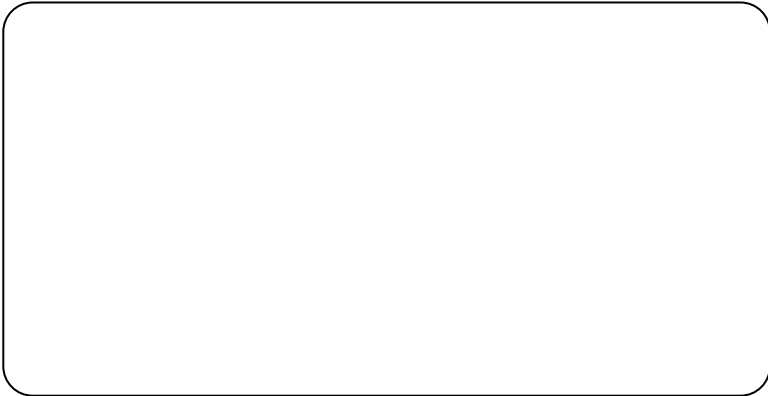



Operating Manual

Platform Stair Lift „Straight“

Issued: April 2024

Version 3.04

Part 1 / 3 of the Original User Manual

ASCENDOR GMBH

PürNSTEIN 43
4120 Neufelden
Austria

Tel.: +43 7282 21900

office@ascendor.com

www.ascendor.com

Table of Contents

1.	Introduction.....	7
2.	Description of the lift	8
2.1	Views of the operating controls	8
2.2	Views of the Ascendor platform stair lift.....	8
2.3	List of parts and controls	9
2.4	Service access hatch and fuse box.....	9
3.	Intended scope of operations	10
3.1	Warranty conditions	11
3.2	Essential operator qualifications	11
3.2.1	User.....	11
3.2.2	Assembly Fitter	11
3.2.3	Maintenance and Service Technicians	11
3.2.4	Lift Attendant	11
3.3	Obligations and duties of a lift operator	12
4.	General description	13
4.1	Lift certification and load warning labels	13
5.	Safety guidelines	14
5.1	Key Symbols	14
6.	Operating the lift	17
6.1	Handheld remote control	17
6.2	Controls fitted to the lift	17
6.2.1	Operation by wall or handheld remote controls.....	17
6.2.2	Controls mounted directly on lift unit.....	17
6.3	Calling and returning the lift	18
6.3.1	Calling or returning the lift unit from the upper to the lower station:.....	18
6.3.2	Calling or returning the lift unit from the lower to the upper station:.....	18
6.4	Access to lift platform	18
6.5	Travelling with the stair lift	19
6.6	Move the lift into parked position	19
6.7	What should I do in the case of an unforeseen stoppage	19
6.7.1	Emergency travel operation	20
6.7.2	Emergency rescue procedure.....	21
7.	Electrical operation and recharging advice.....	22
7.1	Automatic deactivation	22
7.2	Recharging unit	22
7.3	Recharging cycle description	22
8.	Safety features	22
8.1	Safety bars and access ramps	22
8.2	Arresting device	23

8.3	Pressure sensitive contact panel (floor tray)	23
8.4	Contact sensors on access ramps	23
8.5	Emergency STOP button	23
8.6	Emergency CALL via acoustic signal.....	23
8.7	Shear point and toe protection sensors	23
9.	Optional extras	24
9.1	Emergency call options	24
9.1.1	Starting a call	24
9.1.2	During the conversation	24
9.2	SMS remote enquiry	24
9.3	Wall mounted remote control.....	25
9.4	Handheld remote control	25
9.5	Front mounted access ramp	25
9.6	Stainless steel folding seat.....	26
9.7	RGB coloured LED lighting	26
9.7.1	LED colour change	26
9.8	Synthesised speech module	26
9.9	Acoustic and optical warning signal during travel.....	26
9.10	Stainless steel finish.....	27
9.11	Outdoor installation.....	27
9.12	Increased payload 300kg	27
9.13	Long - 300mm access ramp	27
10.	EC Declaration of Conformity.....	28
11.	Operational status.....	29
12.	Trouble shooting guide	30
12.1	When technical problems occur	30
12.2	Responding to technical problems	30
13.	Dismantling and disposal	40
14.	Transport details	40
15.	Installation and commissioning of lift.....	40
16.	Installation of travel rails.....	41
17.	Maintenance guidelines	41
17.1	General maintenance	41
17.2	Check emergency features	41
17.3	Battery maintenance	42
17.4	Annual maintenance check.....	42
17.5	Annual inspection by Lift Inspector	42
18.	Technical data sheet.....	43

For further information, refer to the other parts of the **Original User Manual**:

- Part 2: Assembly Manual
- Part 3: Maintenance and Service Manual

Version:	Issued:	Revision:
V3.00	01.10.2019	New version for Series 10 Platform Stair Lifts
V3.01	19.05.2020	Proofreading
V3.02	21.07.2020	Trouble shooting guide updated
V3.03	14.06.2021	Photos updated, SMS remote enquiry and LED colour change added, div. adjustments
V3.04	24.04.2024	Error messages adjusted, various adjustments

Lift Type:	Series:
PLG7 „Straight“	PLG7-10-xx

! IMPORTANT !



Please read the operating manual before you use the stair lift and ensure that all other persons using the lift have read and clearly understood the contents of this manual.

No right may be derived from the contents of this operator's manual.

The content and technical data included in this manual can be altered at the manufacturer's discretion without prior notification.

1. Introduction

Dear reader! We offer you our congratulations on purchasing this high-quality ASCENDOR platform stair lift and in so doing offer you our thanks for the trust you have shown in our company.

This operating manual has been designed to assist you in the daily use of the lift. Take the time to read the contents thoroughly and familiarise yourself with all the functional possibilities this product has to offer and which are now at your disposal.

Please observe both national and international health and safety regulations, thereby ensuring the safety of yourself and all other users of this product.

Note: This part of the user manual is intended for those persons who are responsible for operating the lift.

2. Description of the lift

2.1 Views of the operating controls

On-board controls fitted to the lift

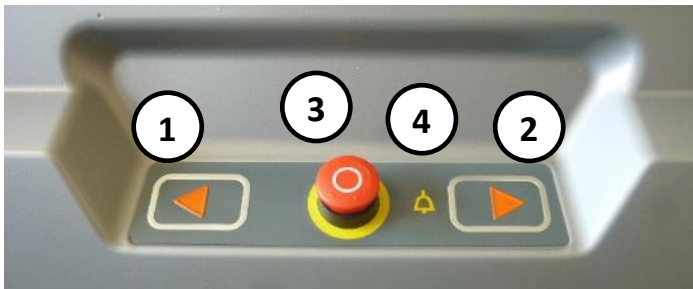

Handheld remote control



Wall mounted remote controls



Key switch positions ON / OFF

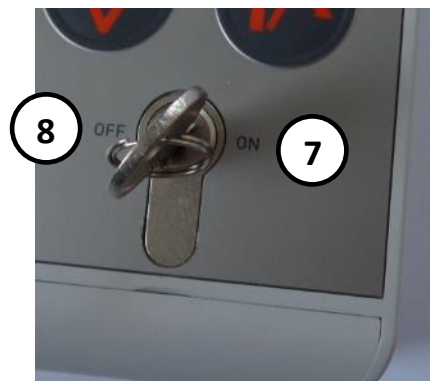

2.2 Views of the Ascendor platform stair lift

Front view –Platform open

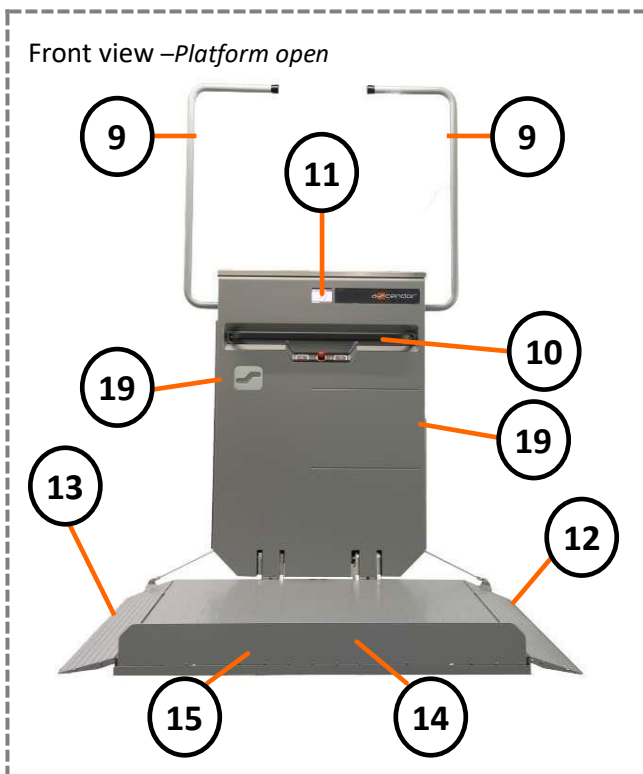

Rear view –Platform closed

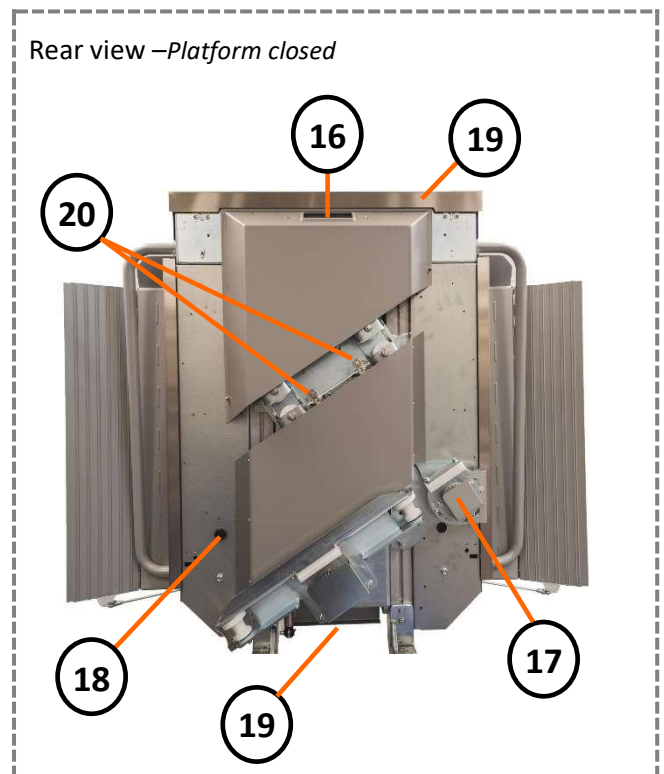

2.3 List of parts and controls

Pos.	Description	Further reference
1	Button for travel UP	
2	Button for travel DOWN	
3	Emergency STOP button	(see Paragraph 8.5.)
4	Emergency assistance call button – <i>(Standard & Options)</i>	(see Paragraph 8.6 and Paragraph 9.1.)
5	CLOSE platform button	Only present on wall-mounted or handheld remote controls
6	OPEN platform button	
7	Key switch position: ON	
8	Key switch position: OFF	(Optional Extras) (see Paragraph 9.3.)
9	Safety bars	(see Paragraph 8.1.)
10	Hand rail – <i>mounted on the front of the lift</i>	
11	Full colour display screen	
12	Right access ramp	(see Paragraph 8.1.)
13	Left access ramp	
14	Standard Board; or optional Front mounted access ramp	(Optional Extras) (see Paragraph 9.5.)
15	Contact tray – (fitted to platform underside)	(see Paragraph 8.3.)
16	Service hatch for Fuse box; Main power switch (ON/OFF)	
17	Emergency brake	(see Paragraph 8.2.)
18	Emergency travel button	(see Paragraph 6.7.)
19	Shear point and toe protection sensors	(Optional Extras) (see Paragraph 8.7.)
20	Limit switches	

2.4 Service access hatch and fuse box

The service access hatch is located at the top, rear of the Lift Unit and is secured with two screws. A connection diagram label is attached to the inside of the service access cover.

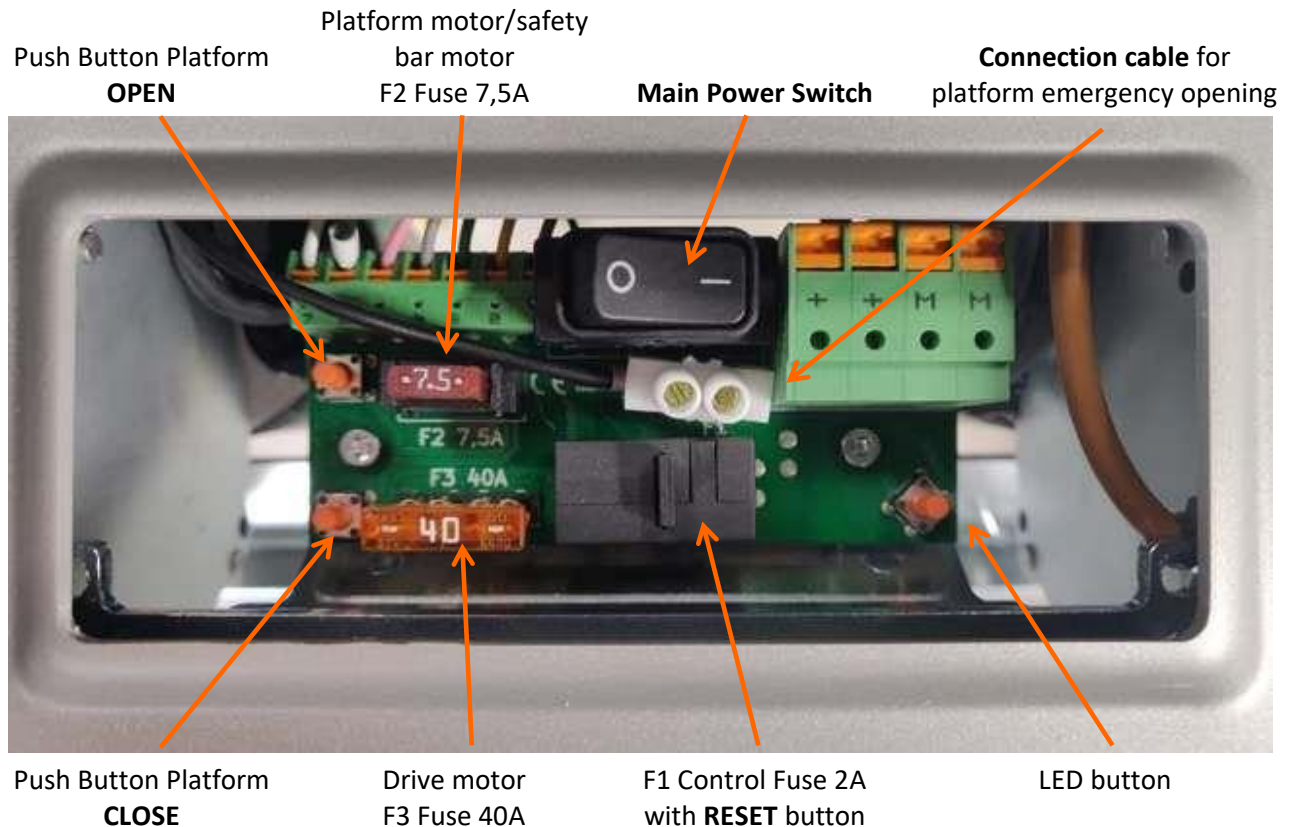

3. Intended scope of operations

The Ascendor platform stair lift PLG7 is a fixed installation, which may only be used for the purpose for which it was originally designed.

Environmental operating conditions:

- Operating temperatures from -20° to +40°C (see: [Paragraph 9.11](#) – Outdoor installation)
- Humidity level between 0 % - 99 %
- Maximum altitude of 2.000 m above sea level
- Maximum proximity of 500m to seawater, if installed outdoors
- The Ascendor platform stair lift is **not suitable for use in surroundings where an increased risk of explosion is present!**

The lift may travel a maximum of 40 meters over a period of 10 minutes. At the same time, if a period of 24 hours is considered, it may cover a maximum of 120 meters of travel.

The instructions included in **Chapter 17** “[Maintenance guidelines](#)” are essential for the normal scope of operations and it is the operators’ responsibility to ensure they are routinely carried out.

The manufacturer accepts no liability for any injuries or mechanical damage that might occur as the result of improper use of the lift or the employment of this lift for any purpose other than that for which it was originally intended.

The lift has been designed to transport one disabled or elderly person, (see [Paragraph 3.2.1](#) – “User”).

- Standing on the platform *or*
- Seated in a wheelchair on the platform *or*,
- Sitting on the **fold-down seat** (see [Paragraph 9.5](#) – Optional extras) *or*
- For transporting stable goods, in the attendance of at least one person

Between pre-determined stations.

The lift is **not intended** for the purposes of transporting:

- Unstable goods!
- More than one person at a time!

IMPORTANT! - In the case of fire, the lift may be used only once during evacuation of the building!

Ascendor platform lifts are manufactured in accordance with the standards governing such appliances. However, these standards alone are no guarantee for a secure and safe operation.

We have therefore provided this operation manual to assist with the everyday use of the lift. Everybody who will operate this lift must have read, understood and strictly adhere to the contents of this manual to ensure that injury and material damage are avoided.

We request you pay close attention to **Chapter 5: “[Safety Guidelines](#)”**.

In addition to the demands placed upon this stair lift and personnel, the immediate surrounding near the travel rails and the lift platform must also be taken into consideration to guarantee safe and reliable operations at all times.

Hazardous situations can arise if the planning of the installation of this lift is not carried out by Ascendor Ltd. or alterations are made to the unit by the operator.

The technical personnel, responsible for the operation, installation and maintenance of our lifts must all have received specific training to ensure that they are qualified to carry out this work.

This **operating manual** must also be made **available for all users to read**, and we recommend the operator to **store it in the immediate vicinity of the lift unit**.

3.1 Warranty conditions

The guarantee is deemed to have become invalid in such cases where damage or injury has occurred as a result of failure to read and observe the instructions in this operating manual and as a result of improper use and failure to maintain and repair the lift and its ancillaries.

Batteries supplied are guaranteed for 6 months from date of delivery.

3.2 Essential operator qualifications

3.2.1 User

All users of an Ascendor platform lift must be in possession of the necessary mental and physical abilities and must have adequate eyesight to be able to identify hazards or obstacles that might present a risk and they must be able to react and respond accordingly.

This applies especially to users with electric powered wheelchairs who intend to use the platform lift. They must have full control of the power wheelchair to be able to stop in time on the platform surface.

The user must also be at least 15 years old and possess the required motor skills to be able to handle the operating elements and engage the emergency stop at all times during travel.

Although the lift is primarily intended for operation by a person in a seated position, standing operation is possible but only for people who are between 140cm and 200cm tall.

Persons who do not meet these criteria are not allowed to operate the lift without the assistance of an accompanying person.

Before they operate the lift, all users must first have received instruction in its use or have thoroughly read and understood the contents of this operation manual.

3.2.2 Assembly Fitter

- Must be trained by an Ascendor approved partner.
- Must be capable of assessing on site, the load bearing capabilities of the walls and supporting elements to which the lift and its equipment will be attached.
- Must be capable of reading and understanding the installation drawings provided.

Ascendor accepts no responsibility or liability for this work.

3.2.3 Maintenance and Service Technicians

Any maintenance work required must be carried out by Ascendor approved partners.

The persons entrusted with this work must have experience in the field of electro-mechanical engineering and be familiar with the lift and its ancillaries.

3.2.4 Lift Attendant

The lift attendant shall be trained by the Lift Inspector and is responsible for ensuring the operational safety of the lift and carrying out the regular safety checks as outlined in [Paragraph 17.2: "Checking safety features"](#).

If the **emergency call option** is fitted (see [Paragraph 9.1](#)), it must be **checked every third day, without fail!**

The lift attendant is also responsible for assisting and freeing lift passengers in an emergency. Refer to [Paragraph 6.7.1 – "Emergency travel"](#) and [Paragraph 6.7.2 – "Emergency rescue procedure"](#) for further details and information.

3.3 Obligations and duties of a lift operator

The operator of the stair lift is duly obliged to ensure the following:

- To ensure the unit is operated correctly and kept in a safe operating condition, i.e. to guarantee that it is regularly maintained and if required repaired by a trained and competent person.
- To ensure the maintenance and emergency access to the mechanical and electrical equipment is kept securely locked at all times and restricted to qualified service personnel only.
- To clearly display the relevant instructions regarding the correct operation of the lift.
- To ensure warning signs are clearly displayed on the stair lift and external control units in the event of a malfunction or breakdown.

The stair lift must be immediately taken out of operation if any defects that could endanger persons are apparent.

Any injuries resulting from accidents that occur during lift operation must be reported to the responsible supervisory authority.

Please observe any further obligations that arise from national or local regulations.

4. General description

Our product is designed to fulfil the requirements of conveniently transporting disabled or elderly people up and down staircases while simultaneously being easy to integrate into existing surroundings.

A great advantage of our lift design is the upper travel rail, which also functions as a handrail.

The travel rails require no additional lubrication, which helps to reduce soiling by dust and dirt. When in motion the travelling speed is limited to a comfortable and practical 0.15 m/s and final drive is achieved by means of a rack and pinion drive.

The operational noise level is less than 63 dB (A). The payload is clearly indicated (see labels below).

The operational load is supported on the travel rails by two set of rollers: two diagonal guide rollers and the gear wheel with its opposing bearings. The supporting rollers are fixed onto two parallel mounted stainless-steel rails.

An electrical motor propels the unit by means of a gear wheel via a self-locking, form fitting connection to a worm gear, which is capable of withstanding the horizontal and vertical loads to which it is subjected.

The travel rails, consisting of an upper stainless steel tube, which also serves as a handrail, and a lower stainless steel round rack, profile fastening elements and fastening strips, is fastened to an existing wall, supports or a steel construction.

An arresting device (emergency brake) ensures that in the event of a mechanical or electrical failure, the lift remains stationary and does not descend down the travel rails.

4.1 Lift certification and load warning labels

The following information is displayed on the certification label:

- Load capacity (payload of the platform)
- Electrical power rating of the complete unit
- Year of manufacture
- Serial number
- Address and telephone no. of the manufacturer

ascendor[®]
LIFTTECHNIK

Stair Lift

Type: **PLG7**

Service load: **225 kg**

Nominal power **0,5 kW**

Year of manufacture: **2023**

SRN: **PLG7-10-07872**

Manufacturer:

Ascendor GmbH

Pürnstern 43

A-4120 Neufelden

+43/7282 21900

Made in Austria



Maximum load capacity
Only 1 Person incl. wheel chair,
maximum weight 225 kg!

5. Safety guidelines

! ATTENTION !

The Ascendor platform stair lift is manufactured in compliance with international safety regulations. Nevertheless, operating errors and misuse can result in serious injuries to the user and/or third parties and cause damage to the lift, its surroundings and property of the operator!

The intention of this chapter is to highlight these dangers and we must **emphasise how important it is that the following information is read and clearly understood!**

5.1 Key Symbols

The following three symbols are used throughout this manual:



This symbol **highlights situations where the failure to observe the instructions** in this manual **will result in a dangerous situation** where **injury or material damage will become unavoidable!**



This symbol **highlights situations where the failure to observe the instructions** in this manual **could result in a dangerous situation** where there is an **increased chance of injury or material damage** occurring.



This symbol **highlights operational steps** where **additional references or explanations are included in this manual.**



Do not begin operating the lift until after you have read and clearly understood the contents of this operating manual.

The instructions and guidelines provided in this manual shall be observed at all times.



Make sure that the complete travel route is free of obstructions or other people before setting the lift in motion.



The travel route must be visible at all times when the lift is in operation.

Do not operate the lift when any form of obstruction (person or object) is on the staircase.



Never exceed the maximum recommended load.



The operator is responsible for ensuring that the lift cannot be used for any purpose other than that for which it is designed (e.g. children playing on the lift).



When mounting the platform with an electric wheelchair, do not drive against the raised ramps, as these can be overloaded by the forces involved.



In the case of fire, the lift may be used only once to evacuate the building!



Ensure that no items of clothing, handbags or other material or personal property are hanging on the travel rails before and during the operation of the lift.



Passengers shall not rest their arms on the safety bars or hang them over the back of the lift unit during operation.



Don't put your hands near the travel rails or other moving parts while the lift is in motion.



Ensure that no parts of the wheelchair or passenger protrude beyond the extents of the lift platform during operation.



Transportation of goods is only allowed when these are stable enough and cannot fall over, move about or slip off the platform while the lift is in operation.



The lift unit and travel rails must be adequately illuminated at all times, either by daylight or an electrical light source (min. 50 Lux). The electrical lighting provided must operate independently of any timing device (e.g. movement sensor).



Always position wheelchair bound passengers on the lift so that they are facing in the direction of travel.



The lift is approved for the transport of only one person at any time!



The passenger on the platform should not make unnecessary e.g. rocking or seesawing movements while the lift is in motion.



Ensure that the handbrake of the wheelchair has been applied before setting the lift in motion!



Never insert solid objects or pour any form of liquids into any slits or openings of the lift unit. This applies irrespective of whether the lift is stationary or in use.



Do not remove, cut, deform or use force when handling any parts or the controls of the lift.



Do not use force to open or close the safety bars during normal operations, or while the lift is in motion. **An emergency is the only exception**, when it is necessary to release a passenger after an unexpected malfunction of the lift.



The lift operation must be immediately stopped if any objects or obstructions are in the direct path or in the near vicinity of the lift or its travel rails during use.



Do not remove any of the signs or labels that are attached to the lift.



All repair and maintenance work must be performed exclusively by trained technicians. For the necessary qualifications, see [Chapter 3.2: "Essential operator qualifications"](#).



Repairs or modifications of the travel rails (handrail or toothed rack) are strictly forbidden!



Do not use the lift in conditions where a high risk of explosion is present. (i.e. - in the event of a gas-leak).



Operating the lift after a temporary or permanent flooding of the lift is strictly forbidden! This applies to both indoor and outdoor installations.



Remove soiling or dirt on the lift or travel rails with the aid of a damp cloth or a commercially available stainless steel (**light lubrication**).

! NEVER USE RUNNING WATER OR A HOSE !



Always use the protective cover provided to cover the lift unit after every operation of an outdoor mounted lift. It is designed to protect them from the environment (i.e. rain).



We recommend that, unless circumstances require otherwise, the lift be inspected at least once a year by a trained technician. A maintenance record shall be kept in a service book or the table provided at the end of the **Maintenance and Service Manual** (Part 3 of the Original User Manual). We advise all customers to entrust an Ascendor approved partner with this work.



If the lift is to be operated without the use of third party assistance, it is essential that extra precautions be provided so that – in case of a malfunction (e.g. mechanical fault, power failure or breakdown) – the passenger can summon help and assistance.



We recommend fitting an [Emergency call option](#) (see **Chapter 9 - Optional extras**) and we advise passengers - always carry a cordless or cellular telephone with them when using the lift!



It is important that the recharger be connected to a permanent electrical supply. As soon as the lift is stationary and parked at either the upper or the lower station, recharging will automatically begin. Only with fully charged batteries can the operational function of the lift be guaranteed.



When using a lift located outdoors, the passenger must wear the appropriate clothing to protect themselves against wind, weather and low temperatures and in case of an unforeseen breakdown.



The transport of pets on the platform is strictly forbidden on safety grounds.



The key in the wall mounted remote control box can only be removed when it has been turned into the '0' position (OFF).



The lift should be operated regularly, we recommend at least once every 2 weeks.

6. Operating the lift

The Ascendor platform stair lift is equipped with a “push-to-run” system, which controls its travel operation. This principle ensures that **the stair lift will only move along the rails as long as the travel command buttons on the lift or remote controls are pressed and held.**

This is designed to give the passenger a feeling of safety and control during travel and prevent panic.

The option of opening and closing the platform can be carried out automatically at the landing with the control unit permanently installed on the landing.

However, the following requirements must apply:

- The particular wall mounted wireless control is only assigned to that specific landing.
- There must be a clear and unrestricted view of the lift and travel route from the operating position.

6.1 Handheld remote control

The handheld remote-control unit allows the operator the greatest amount of freedom when using the lift. You are no longer dependent on the controls mounted either directly on the lift or at the upper or lower stations.

You are free to control the lift via the handheld remote-control unit that can be carried around on the person.

The receiver module is located inside the lift unit and transmits the commands to the control system.



NOTE: It is the sole responsibility of the user to ensure that the path of travel of the lift is visible and unrestricted at all times when operating with the handheld remote control.

6.2 Controls fitted to the lift

6.2.1 Operation by wall or handheld remote controls

For further information, regarding the use of either the lift mounted and external remote controls please refer to; [Paragraph 2.1: “Views of the operating controls”](#) and [Paragraph 2.3: “List of parts and controls”](#).

The following controls can be found on all the remote-control units (external controls):

- a) **Push buttons** to control **UP** and **DOWN** function ([Paragraph 2.1](#); **Pos. 1 & 2**).
- b) **Push buttons** to control platform **OPEN** and **CLOSE** functions ([Paragraph 2.1](#); **Pos. 5 & 6**).

6.2.2 Controls mounted directly on lift unit

The following controls are mounted directly on the lift unit (internal controls):

- a) **Touch sensitive buttons** control the **UP** and **DOWN** functions ([Paragraph 2.1](#); **Pos. 1 & 2**)
- b) **Red push button**, with yellow surround controls the **Emergency stop** function ([Paragraph 2.1](#); **Pos. 3**)
- c) **Emergency assistance call button** ([Paragraph 2.1](#); **Pos. 4**)

6.3 Calling and returning the lift

The Ascendor platform stair lift can be called or returned from any station and sent to another by means of the wall-mounted or handheld remote controls. **This should only be done with the platform raised** (i.e. in 'closed position') and can be **optionally programmed** so that this is **only possible in closed position**.



VERY IMPORTANT! - Before calling, or returning the lift please ensure that the complete travel route is free of obstructions or people!

6.3.1 Calling or returning the lift unit from the upper to the lower station:

Press and hold the drive command button pointing in the direction of the lower station.

After a short delay, the lift will start to move downstairs.

6.3.2 Calling or returning the lift unit from the lower to the upper station:

Press and hold the drive command button pointing in the direction of the upper station.

After a short delay, the lift will start to move upstairs.

6.4 Access to lift platform

The operation of the platform stair lift, its access ramps and safety bars are fully automated (electro-mechanical) and occur as follows:

LIFT LOCATION: LOWER LANDING



Push and hold platform OPEN button

The platform opens (folds down), and both safety bars are raised into the vertical (open) position.

OPTIONAL: Automatic OPEN and CLOSE function of the platform at upper and/or lower landing.

LIFT LOCATION: UPPER LANDING



Push and hold platform OPEN button

The platform opens (folds down), and the safety bars move into the following positions:

The upstairs facing safety bar opens to a vertical position; the downstairs facing safety bar remains in a horizontal position.

OPTIONAL: Automatic OPEN and CLOSE function of the platform at upper and/or lower landing.

In the interest of health and safety, please observe the following advice:



Keep the button pressed until the platform has automatically stopped.

Do not load the platform until it is fully opened!



Before opening the platform, make sure that there are no objects lying either on the floor or in the near vicinity of the lift, which will restrict operation!

6.5 Travelling with the stair lift

LIFT LOCATION: LOWER LANDING

Press and hold the drive command button pointing in the direction of the upper station.

Both safety bars are lowered into horizontal position, the ramps are raised and the lift travels upstairs.

Once the lift has reached the upper landing, **continue to hold the button pressed** until the upstairs safety bar has been raised into the vertical position and the access ramp has been completely lowered.

The passenger may now leave the platform.

LIFT LOCATION: UPPER LANDING

Press and hold the drive command button pointing in the direction of the lower station.

The upstairs safety bar is lowered into the horizontal position, the upstairs ramp is raised and the lift travels downstairs.

Once the lift has reached the lower landing, **continue to hold the button pressed** until both safety bars have been raised into the vertical position and the access ramps have completely opened.

As soon as the travel sequence is complete, release the button and the passenger may leave the platform.

6.6 Move the lift into parked position



VERY IMPORTANT! - The operator must ensure that **there are no objects left on the platform** and that **the folding seat (if fitted) is first properly stowed** before closing the platform with the handheld remote control.

LIFT LOCATION: UPPER OR LOWER LANDING



Push and hold platform CLOSE button.

Both safety bars swing down to the lift unit and the platform folds upwards into the parked position.



To allow the maximum amount of clearance and thereby the greatest access to the stairs and to the upper travel rail, which can be also used as a handrail, we recommend that the lift is always parked downstairs (lower landing) when it is not in use.

6.7 What should I do in the case of an unforeseen stoppage

In the event of the lift stopping, please remain calm and do not panic!

You are not in any danger and nothing untoward can happen to you.

Summon assistance by pushing the emergency call button.

We nonetheless strongly recommend that all users carry a cordless or cellular phone with them at all times. For further information regarding the [Emergency call option](#), please refer to **Paragraph 9.1** in this manual.

6.7.1 Emergency travel operation

Despite the occurrence of a technical fault, it will still be possible to move the Ascendor platform stair lift into a safe position.

PLEASE NOTE: The following emergency travel operation procedure is only to be used in the event of a true emergency! The lift, with a passenger on board is positioned between stations and refuses to function and no other possibility remains to set the lift in motion.

ATTENTION!

Be aware that during emergency travel all the normal safety features of the lift will no longer function!



Emergency travel operations should only be undertaken by trained personnel! (i.e.: The “Lift Attendant”, see [Paragraph 3.2.4](#)).

Please follow this procedure to move the lift in an emergency:

Push and hold both the Emergency-Travel-Button and either UP or DOWN button (on the handheld remote **QR** on-board control panel). The lift will move very slowly in the desired direction.

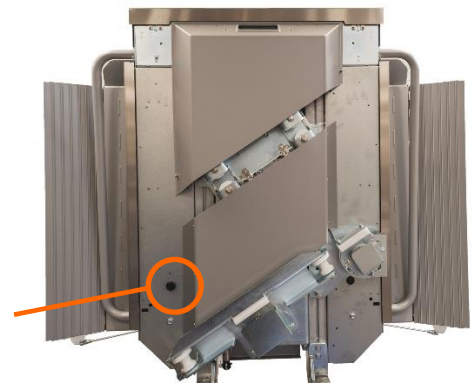

NOTE: The **Emergency-Travel-Button** is located at the **rear of the lift**, on the **lower (i.e. downstairs facing) side of the lift unit**, between the upper handrail and lower drive rail.



WARNING: There is an Increased risk of entanglement and crushing!
Please take all possible precautions to prevent accidents and injury!

ATTENTION:

Unless the situation prevents it, **always move the lift in the direction of the next nearest station.** Upon reaching the station position warning signs and ensure the lift is turned off and cannot be operated. Please contact your Ascendor service partner immediately!



During the emergency travel operation, the emergency limit switches, emergency brake and safety switches for the safety bars are no longer operational. Please pay extra care and attention especially when bringing the lift into its final position in the station.



ATTENTION: If the emergency brake has been released, the lift can only be moved in the direction of the upper landing!

Possible causes of breakdown or operational stoppage:

- Excessive speed causes release of emergency brake.
- Icing up of the platform motor (by outdoor installation).

For detailed information, refer to [Chapter 12](#) - “**Trouble Shooting Guide**”.

6.7.2 Emergency rescue procedure

If the lift refuses to move with the assistance of the emergency-travel-button, the passenger must be freed from the lift platform. Please take the following steps for a rescue in an emergency:

- To free the passenger from the lift, the frictional resistance between the safety bars and safety bar motor must be overcome manually - with the use of force!
- Open the safety bar until it is in a vertical position. **Under no circumstances may the barrier be turned further towards the road.** Please note that the access ramp is mechanically connected to the safety bar and it will open when the safety bar is raised.
- The passenger can now be assisted in leaving the platform, preferably on the upstairs side of the lift.



Emergency rescue procedure may only be undertaken by trained personnel!
(i.e.: The "Lift Attendant", see [Paragraph 3.2.4](#)).



WARNING! - Do not underestimate the risks involved when carrying out this rescue procedure!
(Injuries due to uncontrolled movement of lift, i.e.: fingers trapped or crushed in mechanism, passenger falling from platform, etc.)

To ensure that the lift does not obstruct the stairs, the platform must be folded away by hand and secured with the tension belt provided. The tension belt will have been handed over to you during installation, together with this operating manual.



Ensure tension belt is threaded up over the top of the safety bar.

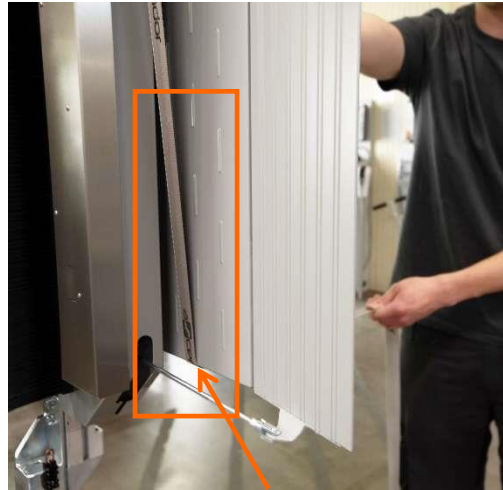

Insert the tension belt **between platform and threaded rod** at the bottom of the lift.

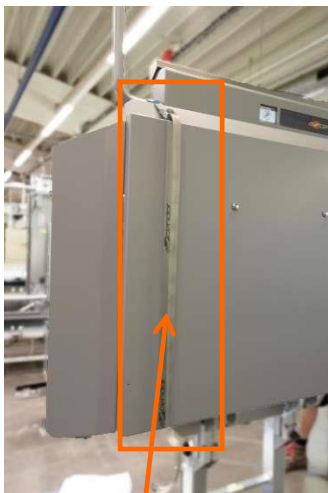

Pay particular attention when tightening the belt **not to scratch the lift surface!**



When a **front mounted access ramp** is fitted, pass the **belt over the top edge** of the ramp.

ATTENTION! – Beware of sudden opening of the platform!

When the tension belt is removed, the platform will fold down suddenly under its own weight.

7. Electrical operation and recharging advice

To guarantee the long term faultless operation of the platform lift, following either a prolonged period without recharging or a lengthy power failure, switch off the lift and disconnect it from the power supply as follows:

- Turn the lift off, using the **main power switch** located under the [Service access hatch](#) (see **Paragraph 2.4**).

It is essential that this procedure be strictly observed otherwise, internal leakage currents will drain the batteries. However, our general recommendation is that the lift should remain permanently connected to the recharger to ensure optimal recharging and ensure a long lifespan of the batteries.

7.1 Automatic deactivation

If, for whatever reason the batteries are not adequately recharged, the lift will automatically deactivate itself after maximum 10 hours, to avoid a deep discharge of the batteries. Before deactivation occurs, an acoustical signal will sound and a message is visible in the display.

To restart the lift, the operator must press the [RESET button](#) (see **Paragraph 2.4**) to begin normal operation.

7.2 Recharging unit

The lift is supplied with a battery charger of the type “Soneil 2403SRL”

This has a charging voltage of 24V DC and a nominal power rating of 48W. The mains voltage supply must be between 90V – 264V AC and the supply frequency must be between 47 – 63Hz.

This unit has been chosen because it has a wide input tolerance range and is therefore suitable for use in almost every part of the world.



7.3 Recharging cycle description

The recharging cycle is split into three distinct stages, which are described below:

1) Deep recharging mode

This mode is intended for recharging deep discharged batteries. When this mode is active the LED flashes. The recharging process begins with weak 0.5 V to 5 V voltage pulses. These have the effect of removing any loose sulfation that has formed during deep discharge

2) Standard recharging mode

The LED lights orange and the recharger switches to a constant current of 2 A until the batteries are fully charged and have reached a voltage of 28,8 V.

3) Standby mode

The LED lights green and the battery voltage is maintained at a constant 27,6 V while the charge current slowly drops to zero. This ensures the recharger can remain permanently connected without causing any damage to the batteries.

If the battery voltage drops below 27,6 V the recharging cycle will repeat stages 2 and 3.

8. Safety features

8.1 Safety bars and access ramps

The safety bars and access ramps – (see [Paragraph 2.2](#), “**Views of the Platform Lift**” Pos. 9, 12 & 13) are designed to prevent people from falling off the platform during normal operations.

8.2 Arresting device

The lift is fitted with an arresting device (see [Paragraph 2.2 – Pos. 17](#)) which guarantees that in the event of a mechanical or electrical failure, uncontrolled movement of the lift down the travel rail is not possible.

8.3 Pressure sensitive contact panel (floor tray)

The contact tray (see [Paragraph 2.2 – Pos. 15](#)) guarantees security against collision with obstructions while traveling in the downstairs direction.

8.4 Contact sensors on access ramps

Contact sensors are fitted to both standard access ramps (see [Paragraph 2.2 – Pos. 12 & 13](#)). Contact with any obstructions in the path of travel will result in the lift coming to an immediate stop. Only the sensor in the direction of travel is active at any one time.

8.5 Emergency STOP button

If the emergency stop button is pressed, (see [Paragraph 2.1 – “Views of the operating controls” Pos. 3](#)) the lift will come to an immediate stop and an acoustic signal will be emitted. To release the emergency-stop button simply turn it to the left.

8.6 Emergency CALL via acoustic signal

Pressing the emergency call button on the lift (see [Paragraph 2.1 - Pos. 4](#)) will sound an acoustic signal.

8.7 Shear point and toe protection sensors

These contact sensor strips are located on the top edge and along both vertical sides of the lift (see [Paragraph 2.2 – Pos.20](#)). They are designed to prevent persons or objects from being trapped while the lift is moving and should be fitted onto lifts when there are shearing points or projecting edges along the travel route, such as windowsills.

Two contact sensor strips are attached to the sides (**Fig.1**) and one along the top edge (**Fig.2**). An additional sensor (**Fig.3**) can be fitted across the bottom edge of lift to prevent toes being accidentally crushed.

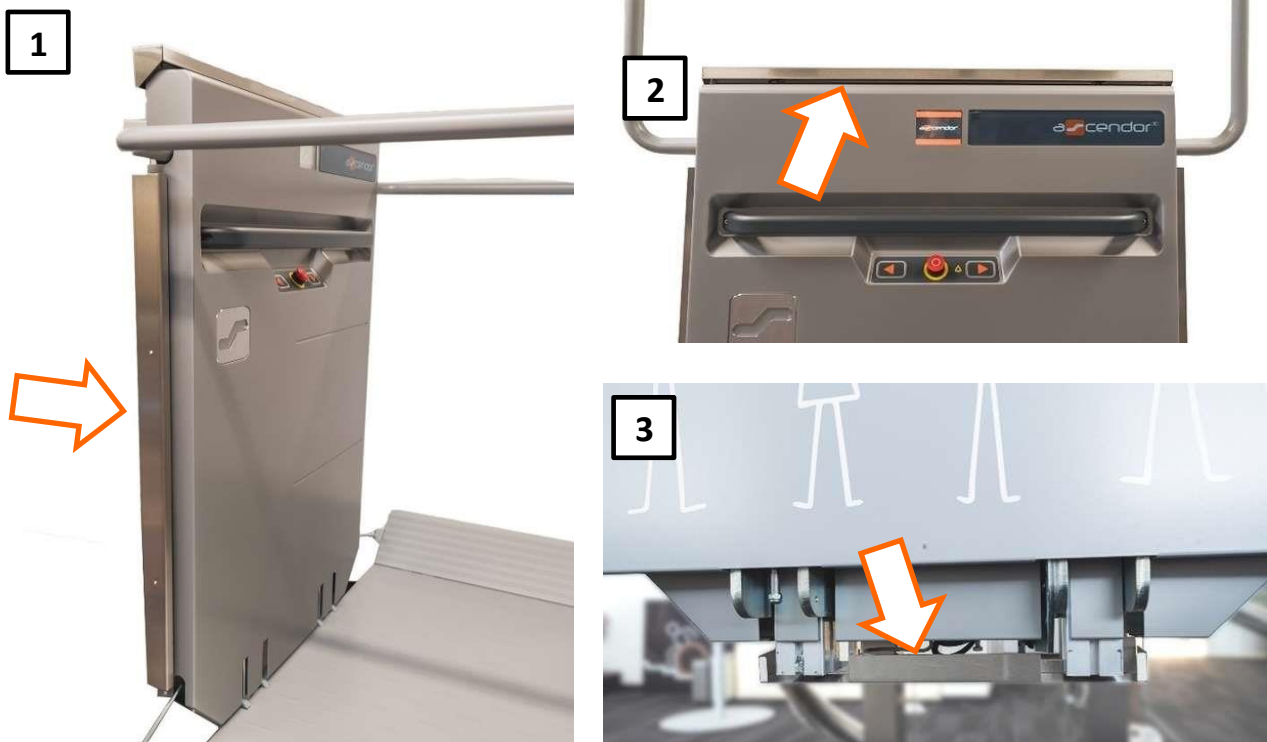

9. Optional extras

Ascendor platform stair lifts can, on request be fitted with a range of optional extras, which have been designed to meet the different requirements of our customers.

9.1 Emergency call options

The lift can be optionally equipped with a UMTS_GSM module. This module must be parameterized with the software of the lift to be operational. With a parameterized module, three telephone numbers with call name can be set in the parameters. These can then be called by the operator and a voice connection established.

However, an emergency call system or the carrying of a cordless or mobile phone is also highly recommended for private use!

9.1.1 Starting a call

If the call button on the lift is pressed for longer than 3 seconds, the display shows the first call number and the call name. A countdown is also shown.

However, the countdown only starts counting down **when the call button is released again.**

E.g.: Matt +447825807666 will be called in 10 seconds.

If the call button is briefly pressed again within the countdown time, the system switches to the second number. The countdown starts counting again from the beginning.

E.g.: Lisa +442380817146 will be called in 10 seconds.

If the call button is briefly pressed again within the countdown time, the system switches to the third number. The countdown starts counting again from the beginning.

E.g.: Maria +448450066103 will be called in 10 seconds.

If the call button is pressed again briefly within the countdown time, the system switches back to the first number. The countdown starts counting again from the beginning.

If the call button is pressed for longer than 5 seconds after a call has been started or within the countdown time, the broadcast call is cancelled.

If no key is pressed during the countdown, the respective number will be called after the countdown is over.

9.1.2 During the conversation

If the call is connected, the call can be ended by briefly pressing the call button again. It is also recognized when the called party ends the call or the other party is busy and the broadcast call is then also ended on the lift.

The called party does not have to confirm the call explicitly, since the caller on the lift has full control of the dialling process!

9.2 SMS remote enquiry

The SMS remote enquiry is only available in combination with a UMTS_GSM module.

The call number of the customer SIM card in the emergency call module can be stored manually in the control unit and read out on the display.

By sending an SMS with a command and a unique synonym to the phone number of the SIM card in the emergency call module, data is returned by the control unit via SMS.

The information is returned in the language set in the lift.

SMS commands are independent of the set language.

The following queries are possible:

- SMS code: #inout
SMS return: current active inputs and outputs
- SMS code: #info
SMS return: content of the information menu
- SMS code: #fault1, #fault2, . . . , #fault10
SMS return: query of the error memory (#fault1: error 1 - 4, #fault2: error 5 - 8, . . .)
- SMS code: #data
SMS return: Operating data
- SMS code: #paraP005, #paraP008, #paraB002, . . .
SMS return: setting of the requested parameter

For more detailed information, please refer to the maintenance and service instructions.

9.3 Wall mounted remote control

(- with secure key switch activated control unit)

This wall mounted control panel can only be operated once it has been activated with the key provided.

This feature guarantees secure operation and prevents lift use by unauthorised persons.



9.4 Handheld remote control

This option is designed to offer our customers the greatest freedom of personal movement when operating the lift.

All the most important functions (travel UP and DOWN, platform OPEN and CLOSE) are included on the ergonomically designed handheld remote control, which the user can conveniently carry on their person at all times.



9.5 Front mounted access ramp

In some situations, due to lack of available space, it is not possible to load a wheelchair onto the platform using the standard access ramps fitted at each end.

In such cases, an extra ramp can be fitted along the front edge of the platform to improve the all-round accessibility for wheelchair users.

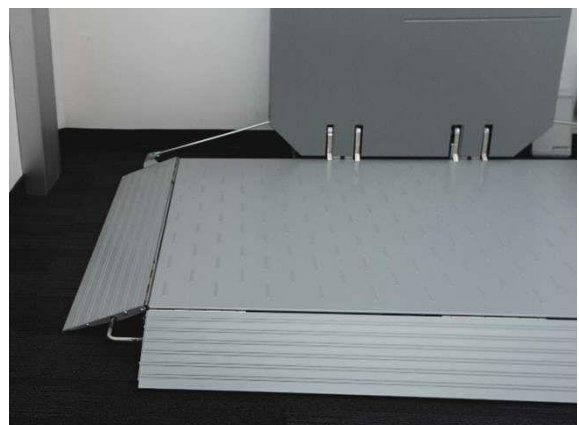

9.6 Stainless steel folding seat

This folding seat provides the passenger with the possibility of sitting down while the lift is in motion.

The folding seat is made of stainless steel and offers a seating space of 38 x 38 cm. It is capable of carrying a maximum load of 115kg. When it is not in use, it can simply be folded away.

IMPORTANT! The seated passenger must be physically capable of grasping and holding on to the safety bars in case of an unforeseen stopping of the lift



9.7 RGB coloured LED lighting

Our series 10 platform stair lifts can be equipped with coloured LED lighting along three sides of the front cover. Different colour combinations can be set to meet individual customer requirements. In addition, the colours green and red are used to impart information about the operational status of the lift.

Green = Everything in working order! / Batteries are charged.

Red = No charge in batteries, or a warning that a problem has occurred during travel.

These signals will be displayed as long as the travel button (UP or DOWN) is pressed.



9.7.1 LED colour change

Procedure Colour change LED lighting:

- Press emergency stop button
- Open service access (see [section 2.4](#))
- Hold down colour change → LED button (see [section 2.4](#)), change colour by pressing the "platform open or close" buttons
- Adjust intensity Keep LED button → (see [section 2.4](#)) pressed, adjust intensity by pressing the "UP or DOWN button" on the lift (see [section 2.1 - Pos1&2](#)) to adjust the intensity.
- Close service access and unlock emergency stop button

The set colour of the LED lighting is now active while driving.

9.8 Synthesised speech module

Our platform stair lifts can be equipped with a synthesised speech module; the following languages are presently available: **German, English** and **French**. This option is designed to support and enhance the comprehensive range of information offered in our new graphic display.

9.9 Acoustic and optical warning signal during travel

To meet the legal requirements for installation in public buildings and spaces, we offer the option of fitting extra acoustic and optical warnings in the form of a beeper and a flashing light.

9.10 Stainless steel finish

Ascendor platform stair lifts provide the evidence that mobility and functional elegance can be combined in an attractive design.

An elegant metallic-silver finish, similar to RAL 9006 is the standard finish; on request, we can also manufacture our platform stair lifts in an attractive polished, stainless steel finish.



9.11 Outdoor installation

Ascendor platform stair lifts are not only designed for indoor use but can also offer you increased mobility outdoors with the possibility to surmount stairs, slopes, ramps and other structural obstacles.

Equipped with the necessary weatherproof modifications, our stair lifts can be installed and operated outdoors without restrictions.

We refer to chapter 3 "Intended scope of operations".



9.12 Increased payload 300kg

In situations where, for whatever reason the standard payload of 225kg is not considered enough, we can offer an increased load capacity of 300kg with overload detection for increased security.



9.13 Long - 300mm access ramp

Sometimes, due to actual on-site conditions, the distance between the lift platform and stairs is too large or the angle at ground level is too steep to be overcome with the standard ramp. In such cases, we recommend fitting our 300mm long ramp to overcome these obstacles.

*This option is not available in stainless steel.



10. EC Declaration of Conformity

For machines according to the machinery directive 2006/42/EC in the current version.

Manufacturer: Ascendor Ltd, Drautendorf 48, A-4174 Niederwaldkirchen
hereby declares under sole responsibility, that the product identified below:

Description: Platform Stair Lift
Model and commercial description: PLG7 „Straight“
Manufactured from Month/Year: 09/2019

Complies with the relevant harmonisation legislation of the following European Union product directives:

- 2006/42/EC Machinery guidelines and directives

Technical specifications are in accordance with the following directives:

- EN ISO 12100 Safety of machinery – General principles for design (ISO12100:2010)
- EN ISO 13849 Safety of machinery – Safety-related parts of control systems (ISO13849-1:2016)
- EN ISO 13850 Safety of machinery – Emergency Stop Function (ISO13850:2015)
- EN ISO 13857 Safety of machinery - Safety distances to hazardous zones (ISO13857:2008)
- EN ISO 14119 Safety of machinery – Interlocking devices associated with guards (ISO14119:2013)
- EN ISO 14120 Safety of machinery - Design and construction of fixed and moveable guards (ISO14120:2016)
- EN 349 Safety of machinery - Minimum gaps to avoid crushing of parts of the human body (EN349:2008)
- EN ISO 14118 Safety of machinery - Prevention of unexpected start-up (ISO14118:2018)
- EN 60204-1 Safety of machinery – Electrical equipment of machines (EN60204-1:2009)
- EN 81-40 Safety regulations for the construction and installation of lifts – Part 40: Stair lifts and inclined lifting platforms intended for persons with impaired mobility (EN81-40:2009).

Fulfils the specific requirements in acc. with Machinery guidelines and directives 2006/42/EG:

The product has been placed on the market in accordance with Article 12 (3) (b) of the Machinery Directive:
The machine is included in Annex IV of the Machinery guidelines and directives.
EC type examination according to Annex IX as well as internal production control according to Annex VIII.

Fulfils the specific requirements in acc. with EMV-guidelines 2014/30/EU:

The product was placed on the market in accordance with Article 14 a), internal production control in accordance with Annex II of the EMC Directive.

Fulfils the specific requirements in acc. with RED-guidelines 2014/53/EU:

The product was placed on the market in accordance with Article § 17 (2) a), b) or c) or Article § 17 (3) a), b) or c) or Article § 17 (4) a) or b) of the RED- Directive.

The administration of the technical documentation of this equipment is the responsibility of:





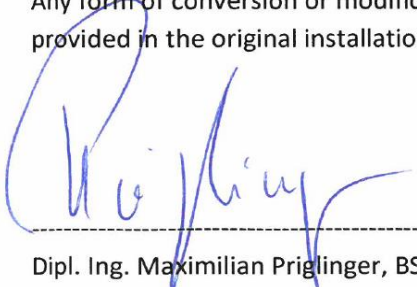

Ascendor GmbH, Technical Development and Documentation Department
Drautendorf 48, 4174 Niederwaldkirchen, Austria

Any form of conversion or modification to the machine as well as the failure to observe the terms and instructions provided in the original installation, operating and service manuals, will render this conformity declaration invalid.



Dipl. Ing. Maximilian Priglinger, BSC. Managing Director Ascendor Ltd. Niederwaldkirchen, on 15.09.2019

11. Operational status

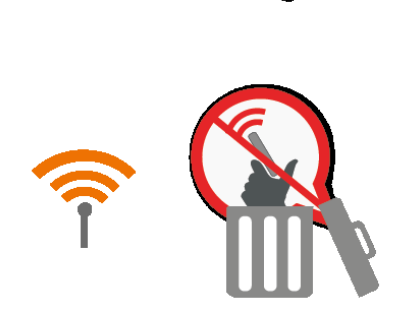
DISPLAY READOUT	FUNCTIONAL DESCRIPTION
	<p>MAIN SCREEN DISPLAY</p>
	<p>LEFT travel command button on lift activated On-board button on lift or PCB has been activated</p>
	<p>RIGHT travel command button on lift activated On-board button on lift or PCB has been activated</p>
	<p>Travel command on transmitter activated Travel command on wall-mounted or handheld control has been activated</p>
	<p>Teach-in procedure for handheld remote control Receiver is in teach-in mode, Transmitter can be memorised (Press and hold platform OPEN & CLOSE buttons simultaneously for 10 secs.)</p>
	<p>Transmitter has been successfully memorised Receiver has been successfully programmed</p>
	<p>Transmitter status deleted All memorised transmitters have been deleted</p>

12. Trouble shooting guide

12.1 When technical problems occur

In the event of technical malfunctions, a service technician must be contacted immediately, and the malfunction must be repaired as quickly as possible. Before the repair is carried out, the lift system must be marked with appropriate signs ("Lift out of order") and affected lift users must be informed of the circumstance.





In the event that a person is on the platform during a malfunction, proceed as described in [Paragraph 6.7.1: "Emergency travel operation"](#) and [Section 6.7.2: "Emergency rescue procedure"](#).

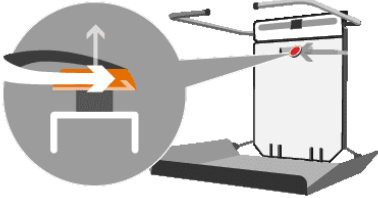

During emergency travel or rescue operation, observe all the safety instructions contained in this manual.

12.2 Responding to technical problems



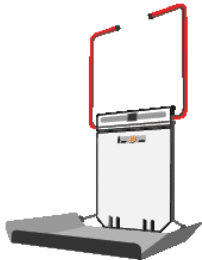
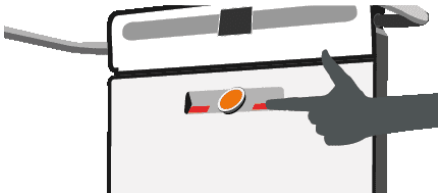
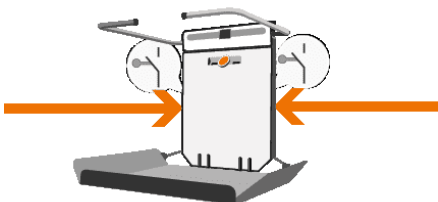
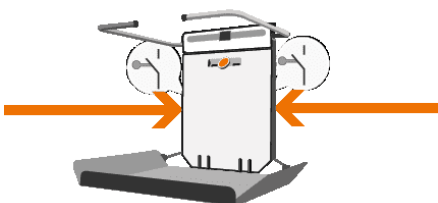
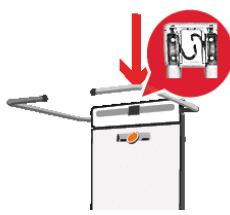

An acoustic signal will sound whenever the on-board diagnostic system detects a fault.

An appropriate graphic image will be displayed on the screen; you should respond to each fault by following the measures outlined in the right-hand column below:

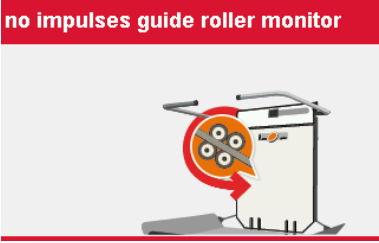
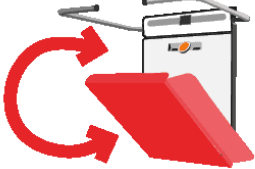
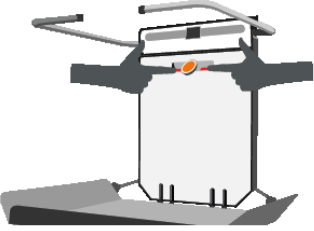
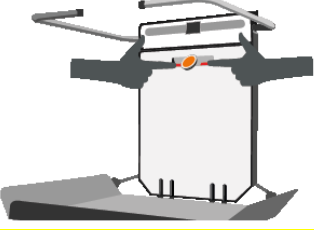

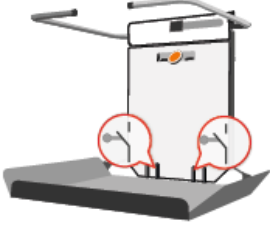

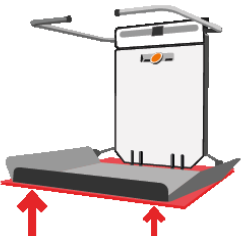
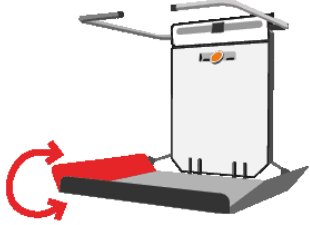
DISPLAY READOUT	FAULT and SOLUTION
<p>Emergency STOP activated</p> 	<p>Fault: Emergency STOP button has been activated.</p> <p>Solution: Release the emergency STOP button (Turn button to the left)</p>
<p>Weak battery charge</p> 	<p>Fault: Battery voltage has fallen below minimum charge. Batteries are damaged, no charge.</p> <p>Solution: Recharge or replace batteries.</p>
<p>Maximum load exceeded</p> 	<p>Fault: Maximum load capacity of lift has been exceeded</p> <p>Solution: Reduce the load on platform</p>
<p>Overload platform motor</p> 	<p>Fault: Platform motor needs too much current</p> <p>Solution: Remove weight from the platform before closing the platform</p>

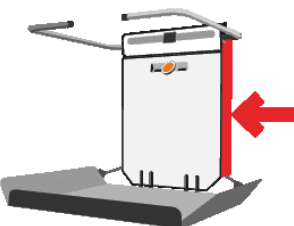
DISPLAY READOUT	FAULT and SOLUTION
<p>Safety bar motors overloaded</p> 	<p>Fault: Safety bars are blocked or move tight</p> <p>Solution: Remove obstruction or check current value of motors</p>
<p>On-board controls activated - platform is closed</p> 	<p>Fault: On-board controls are permanently activated.</p> <p>Solution: Open the platform with remote and check if dirt or water is activating the membrane buttons on lift</p>
<p>Both limit switches activated</p> 	<p>Fault: Upper and lower limit switches are pressed at the same time</p> <p>Solution: Inspect both limit switches Check switches are functioning correctly</p>
<p>Limit switch defective</p> 	<p>Fault: NC and NO contacts do not switch in parallel</p> <p>Solution: Check the limit switches, Check the function of the limit switches</p>
<p>F2 Fuse 7,5A is broken</p> 	<p>Fault: Short circuit of platform or safety bar motors.</p> <p>Solution: Replace F2 Fuse 7,5A</p>
<p>F3 Fuse broken</p> 	<p>Fault: Short circuit of drive motor, Faulty motor controller.</p> <p>Solution: Replace F3 Fuse 40A (PLV9 60A), Inspect motor controller, Inspect drive motor Check safety gear</p>

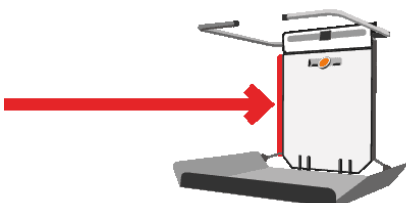
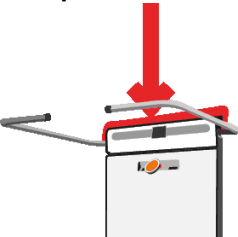
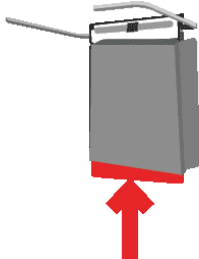
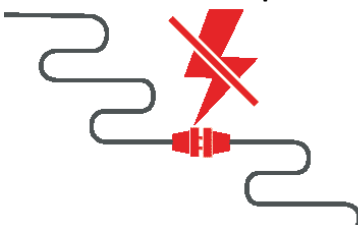
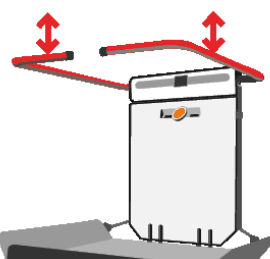
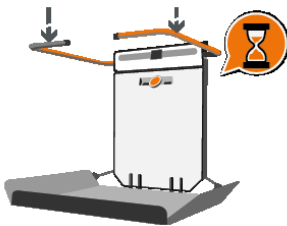
DISPLAY READOUT	FAULT and SOLUTION
<p data-bbox="357 286 612 315">Travel sensor broken</p>  	<p data-bbox="991 226 1305 255">(Only for lift type "PLK8")</p> <p data-bbox="1110 262 1182 291">Fault: Travel sensor broken, Travel sensor incorrectly adjusted, False parameter settings.</p> <p data-bbox="1090 443 1203 472">Solution: Inspect the sensor, Check travel distances, Check parameter settings</p> <p data-bbox="991 618 1305 647">(Only for lift type "PLK8")</p> <p data-bbox="1110 654 1182 683">Fault: Defective track roller monitoring, Incorrect parameterization</p> <p data-bbox="1090 797 1203 826">Solution: Check parameterization, check the sensor on the safety gear and replace if necessary</p>
<p data-bbox="308 1012 663 1041">Platform not correctly closed</p> 	<p data-bbox="1110 1021 1182 1050">Fault: Platform has not been correctly closed.</p> <p data-bbox="1090 1128 1203 1158">Solution: Close (raise) the platform completely using the remote controls</p>
<p data-bbox="304 1285 667 1314">Both travel buttons activated</p> 	<p data-bbox="1110 1323 1182 1352">Fault: Both travel buttons have been operated at once.</p> <p data-bbox="1090 1431 1203 1460">Solution: Check if dirt or water is activating the membrane buttons on lift</p>
<p data-bbox="244 1592 726 1621">Both fold buttons (open/close) pressed</p> 	<p data-bbox="1110 1626 1182 1655">Fault: Both fold buttons (open/close) on remote or in service hatch are pressed</p> <p data-bbox="1090 1767 1203 1796">Solution: Check whether the button is stuck</p>

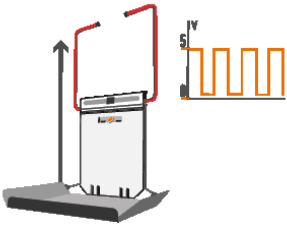
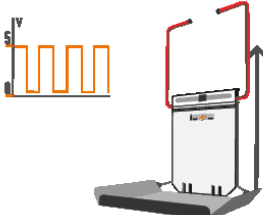
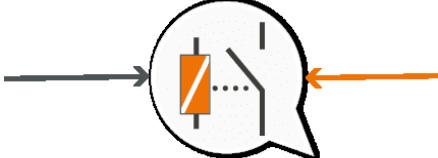
DISPLAY READOUT	FAULT and SOLUTION
<p>Switches b20 and b19 both active</p> 	<p>Fault: Both switches not pressed (NC contact)</p> <p>Solution: Platform opened → adjust switch b19 Platform closed → adjust switch b20</p>
<p>Arresting gear activated</p> 	<p>Fault: Arresting gear has been released.</p> <p>Solution: Reset arresting gear, Check for cause of release, Visually inspect arresting hook</p>
<p>Contact tray depressed</p> 	<p>Fault: Obstruction has activated switches in tray</p> <p>Solution: Remove obstruction and inspect platform to ensure it can move freely.</p>
<p>Contact sensor on left side ramp</p> 	<p>Fault: Obstacle has activated ramp sensor on the left.</p> <p>Solution: Remove obstacle and check that ramp can move freely again.</p>
<p>Contact sensor on right side ramp</p> 	<p>Fault: Obstacle has activated ramp sensor on the right.</p> <p>Solution: Remove obstacle and check that ramp can move freely again.</p>
<p>Shear point sensor on right side</p> 	<p>Fault: Obstacle has activated contact sensor on the right.</p> <p>Solution: Remove obstacle and check that contact strip can move freely again.</p>

DISPLAY READOUT	FAULT and SOLUTION
<p>Shear point sensor on left side</p> 	<p>Fault: Obstacle has activated contact sensor on the left.</p> <p>Solution: Remove obstacle and check that contact strip can move freely again.</p>
<p>Shear point sensor on top</p> 	<p>Fault: Obstacle has activated sensor on the top.</p> <p>Solution: Remove obstacle and check that contact strip can move freely again.</p>
<p>Toe protection sensor</p> 	<p>Fault: Obstacle has activated sensor on the bottom.</p> <p>Solution: Remove obstacle and check that contact strip can move freely again.</p>
<p>No electrical power</p> 	<p>Fault: Recharger is not plugged in or broken</p> <p>Solution: Inspect the recharger for function and check the mains supply voltage</p>
<p>Safety bars manually operated</p> 	<p>Fault: Safety bars have been raised manually</p> <p>Solution: Operate safety bars with OPEN and CLOSE buttons.</p>
<p>Safety bar motors broken</p> 	<p>Fault: Safety bar motor not connected or broken.</p> <p>Solution: Inspect safety bar motors.</p>

DISPLAY READOUT	FAULT and SOLUTION
<p>Hall-sensor on upstairs facing safety bar broken</p> 	<p>Fault: Hall-sensor on safety bar motor disconnected or faulty; incorrect parameter settings.</p> <p>Solution: Inspect Hall-sensor, Check parameter settings.</p>
<p>Hall-sensor on downstairs facing safety bar broken</p> 	<p>Fault: Hall-sensor on safety bar motor disconnected or faulty; incorrect parameter settings.</p> <p>Solution: Inspect Hall-sensor, Check parameter settings.</p>
<p>Main circuit breaker F1 broken</p> 	<p>Fault: Main circuit breaker F1 is broken.</p> <p>Solution: Replace main circuit F1 Fuse.</p>
<p>Master contact monitoring</p> 	<p>Fault: Master contact broken, incorrect parameter settings.</p> <p>Solution: Inspect master contact, Check parameter settings.</p>
<p>Emergency travel button activated</p> 	<p>Fault: Emergency travel button is pressed.</p> <p>Solution: Release emergency travel button.</p>
<p>Lift is not in parked position</p> 	<p>Fault: Lift unit is not correctly positioned at upper or lower landing or parking place.</p> <p>Solution: Operate lift and move it into the correct position.</p>

DISPLAY READOUT

FAULT and SOLUTION

Wireless receiver malfunction



Fault:

Signals sent by external transmitters are not correctly received.

Solution:

Reduce distance between transmitter and receiver,
Check receiver module function.

Transmitter batteries low voltage



Fault:

Batteries in wall or handheld controls have no charge.

Solution:

Replace the batteries.

Communication problem wireless transmitter



Fault:

Wireless transmitter reports communications problem.

Solution:

Reduce distance between transmitter and receiver,
Check transmitter module function.

Opening platform not allowed



Fault:

Lift unit is in parking position.

Solution:

Move lift into normal station position.

Motorised ramp limit switch not reached



Fault:

Motorised ramp not closed, limit switch not set correctly or defective, wrong parameter set

Solution:

Inspect motorised ramp limit switch,
Check parameter settings.

(Only for lift type "PLK8")







Fault:



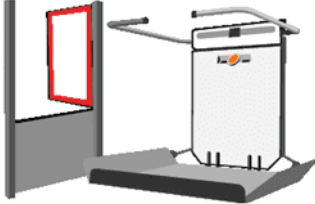



Teach-speed-drive not yet carried out.





Solution:

Carry out Teach-speed-drive, see
Maintenance manual

No test run carried out, the platformlift runs at reduced speed

DISPLAY READOUT	FAULT and SOLUTION
<p>Door not closed</p> 	<p>(Only for lift type PLV9)</p> <p>Fault: Door is not properly closed.</p> <p>Solution: Close door, inspect contacts, Check parameter settings.</p>
<p>Door not locked</p> 	<p>(Only for lift type PLV9)</p> <p>Fault: Door closed not securely locked.</p> <p>Solution: Inspect door latch mechanism, Check parameter settings.</p>
<p>Door latch blocked</p> 	<p>(Only for lift type PLV9)</p> <p>Cause: Door latch is activated but does not unlock.</p> <p>Measure: Check door latch, check door setting</p>
<p>Travel with reserve input</p> 	<p>Fault: A reserve input must be available to allow travel permission.</p> <p>Solution: Inspect wiring of external controls.</p>
<p>Open or close platform with reserve input</p> 	<p>Fault: A reserve input must be available to allow travel permission.</p> <p>Solution: Inspect wiring of external controls.</p>
<p>UMTS_LINK_ERR_WRITE_PHONEBOOK (Code 1)</p> 	<p>Cause: Phone number/name could not be written into the address book of the SIM card</p> <p>Measure: Check phone number, enter a shorter name</p>

DISPLAY READOUT	FAULT and SOLUTION
<p>UMTS_LINK_ERR_WRITE_FLASH (Code 2)</p> 	<p>Cause: An error occurred while writing the update</p> <p>Measure: Start update again</p>
<p>Faulty emergency call module (Code 4)</p> 	<p>Fault: Emergency call module is not dialled into the mobile network</p> <p>Solution: Lift Off/On, check mobile signal</p>
<p>UMTS_LINK_ERR_NO_SIM (Code 8)</p> 	<p>Cause: No SIM card inserted</p> <p>Measure: Insert SIM card</p>
<p>UMTS_LINK_ERR_SIM_LOCKED (code 10)</p> 	<p>Cause: SIM card is locked</p> <p>Measure: Delete PIN code from SIM card</p>
<p>UMTS_LINK_ERR_PWROFF (code 20)</p> 	<p>Cause: Modem not ready</p> <p>Measure: Check emergency call module, check parameter settings.</p>
<p>UMTS_LINK_ERR_AUDIO_OFF (code 40)</p> 	<p>Cause: Error Audio Chip</p> <p>Measure: Check emergency call module, check parameter settings</p>

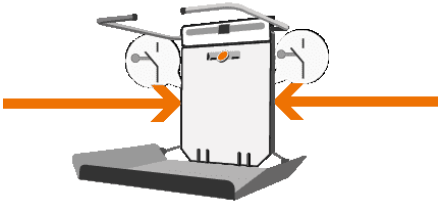
DISPLAY READOUT	FAULT and SOLUTION
<p>If there are several errors, the codes are to be added (hexadecimal)</p> 	<p>For example: UMTS_LINK_ERR_SIM_LOCKED and UMTS_LINK_ERR_PWROFF = Code 30</p>
<p>Emergency call module not connected</p> 	<p>Fault: Emergency call module is not connected, wrong parameter settings.</p> <p>Solution: Check emergency call module is functioning, Check parameter settings.</p>
<p>On-board controls have priority</p> 	<p>Fault: Lift only operates via on-board controls, Incorrect parameter settings.</p> <p>Solution: Lift may only travel in opened platform state with the use of on-board control buttons.</p>
<p>Motor controller + Fault Code</p> 	<p>Fault: Motor controller is broken.</p> <p>Solution: Inspect motor controller, Replace motor controller.</p>
<p>Safety bar switch –b6.1 incorrectly adjusted</p> 	<p>Fault: Micro-switch b6.1 on downstairs facing safety bar is incorrectly adjusted</p> <p>Solution: Adjust the safety switch cams</p>

13. Dismantling and disposal

The dismantling and disposal of the lift unit should only be carried out by an approved Ascendor partner.

In accordance with the European guideline **2012/19/EU** concerning the disposal of used electrical equipment and its implementation in accordance with local regulations, used electrical equipment must be collected separately and recycled in an environmentally friendly manner.



14. Transport details

The size and weight of your platform stair lift will depend on the exact details of the lift ordered.

The weight is displayed on the certification label fitted on each lift.

The transportation of the lift and its ancillaries are only to be undertaken under the supervision of a recognised shipping company or forwarding agent. Damages, which occur during transport under any other circumstances, are not covered by guarantee.

15. Installation and commissioning of lift

The installation and operational commissioning may only be carried out by qualified personnel who have been trained and approved by Ascendor or its partners.

A prior examination of the load bearing capabilities of the walls and supporting elements to which the lift and its equipment will be attached must first be made by installation fitters or a qualified structural engineer.

During installation, special care and attention must be paid to ensure that the operation of the lift cannot be obstructed or disturbed by vibrations or contact from any other appliances in the near vicinity.

These could have an adverse effect upon the electronics or precision engineering of the unit

16. Installation of travel rails

The detailed installation drawing for your platform lift can be found in the cardboard box, which is packed inside the main wooden deliver crate.

This box also includes the installation material, the battery charger and remote controls (handheld remote or wall-mounted housing).

For more information concerning the installation of the lift, refer to **Part 2 of the Original User Manual – Assembly Instruction Manual**.

If any questions or problems arise during installation, please do not hesitate to contact your Ascendor partner or our own customer advice service.

17. Maintenance guidelines



In the interest of health and safety, do not forget to turn off the **main power switch** (see [Paragraph 2.4 “Service access hatch and fuse box”](#)) and disconnect the lift from the electrical supply before carrying out any form of servicing, repair or maintenance work!

17.1 General maintenance

The following maintenance work can be carried out by the customer / operator or by designated personnel:

- **To remove excessive soiling or dirt from the toothed travel rails** (black marks of compressed dust), the rails can be **cleaned using a light lubricating, stainless-steel cleaning spray**. After cleaning the upper travel rail with any form of degreasing agent, the rail should be treated with stainless steel cleaning spray to ensure a smooth ride.
- In the course of time, the **hinges of the access ramps and the platform** may begin to emit squeaking **noises during operations** as a result of friction and wear. This can be **eliminated by applying commercially available lubricant** to the affected parts.
- We recommend removing any excessive soiling or dirt from the platform and ramps with the aid of a damp cloth or mop and drying thoroughly afterwards before resuming operation.
- Squeaking noises can occur due to contamination of the guide tubes. These can be contained by cleaning and using silicone lubricants.



WARNING! There is a risk of being cut by sharp edges when working on the drive rail!
We recommend that personnel wear safety gloves while carrying out maintenance work.

17.2 Check emergency features

In addition, all emergency and safety features should be regularly checked for functionality as follows:

Features to be examined	Check timetable		Function
• Emergency STOP button	press once a month	→	Lift unit stops
• Emergency CALL button	press once a month	→	Audible signal is heard
• Pressure sensitive contact tray (platform underside)	press once every 6 months	→	Travel DOWN stops
• Sensors on access ramps	press once every 6 months	→	Travel UP/DOWN stops
• All other contact sensor strips	press once every 6 months	→	Lift unit stops

IMPORTANT! Failure to observe this routine check procedure will result in the guarantee becoming invalid!

17.3 Battery maintenance

The lifespan of the batteries averages 3-5 years.

To ensure the operational reliability of your platform lift, we recommend that the batteries be replaced every 3 years. This should be undertaken by a qualified service technician.



The lift should be operated at least once every 2 weeks.

Use the rain cover included for outdoor installations while the lift is not in use in order to protect it from the weather.

17.4 Annual maintenance check

This platform stair lift should be serviced as required, it should however, be subjected to a thorough inspection and service at least once every year in accordance with the instructions in **Part 3 of the Original User Manual** the **Maintenance and Service Manual**.

To guarantee the safety and reliability of this product, all repair, maintenance or adjustment work required and the inspection should only be performed by Ascendor partners or qualified service technicians.

To guarantee reliability, only use original Ascendor replacement parts.

Damages, which can be proven to have occurred due to neglect, failure to observe the checks outlined above or faulty maintenance or repair work are not covered by guarantee!

For further information, refer to **Paragraph 3.1** "[Warranty Conditions](#)".

17.5 Annual inspection by Lift Inspector

In addition to the maintenance carried out by service technicians, the lift must be inspected once a year by an authorised Lift Inspector. The commissioning of the inspection is the responsibility of the operator.



Only necessary if required by national law!

18. Technical data sheet

Standard equipment:

- Fully automatic operation of safety bars and platform
- Full colour display screen
- Handrail and toothed rack drive rail made from stainless steel
- Operating panel with modern sensor buttons
- Gentle start and gentle stop
- Emergency call button and emergency stop button
- Obstruction sensors mounted on all sides
- 24V-battery operation, recharger included

Space requirements:

- 27 cm with platform folded closed

Platform sizes in mm

- 800 x 800 / 800 x 760 / 800 x 710 / 800 x 650
- 900 x 800 / 900 x 760
- 1000 x 800 / 1000 x 710
- 1000 x 900 (optional)
- 1210 x 830 / 1250 x 800 (optional)
- 1300 x 800 (optional)

Load capacity:

- 225 kg Standard
- 300 kg (optional)

Operating angle:

- 0-47° Standard
- 0-50° (optional)

Operating speed:

- 0,11 – 0,15 m/s

Acceleration:

- The maximum effective acceleration under load does not exceed 2,5 m/s²

Noise level:

- The operational noise level of the lift does not exceed 63 dB (A)

Operating controls:

- Wireless remote controls
 - Secure, key operated wall mounted housing
 - Ergonomic handheld remote control

Colour:

- Metallic silver RAL 9006 (Standard)
- RAL-colour (optional – *on request*)
- Stainless steel finish (optional – *on request*)

Materials:

- Lightweight, powder coated, steel-/aluminium construction
- Internal supporting elements made from zinc-coated steel
- Standard covering panels are made from scratch resistant plastic

Travel rails:

- Clean, stainless steel tubular upper handrail
- Stainless steel solid bar toothed rack lower drive rail



ASCENDOR GMBH

PürNSTEIN 43
4120 Neufelden
Austria

Tel.: +43 7282 21900

office@ascendor.com

www.ascendor.com