

TOMTAR®

TOMTAR MR-S & TOMTAR MR-LG
Standard and lightweight wheelchair
User manual Version 3.2

EN



Record of product identification data

We recommend that you write down your product identification data below (found on product label), so that you have these on hand should you require any further information about your product. (see chapter product labelling)*

TYP Type / model:	
REF Item No. / REF:	
SN Serial number:	
 Date of manufacture:	
Other information/notes:	

* The identification data on your product label may differ on custom-made devices.

Thank you for choosing the TOMTAR MR-S / MR-LG manual wheelchair from DIETZ.

Read these operating instructions carefully before starting to use your new TOMTAR MR-S / MR-LG. They contain important safety instructions and valuable tips on correctly using the wheelchair.

They also contain information concerning operational safety, road safety and the best possible value retention of your wheelchair.

If you have any questions or require additional information, please contact the specialist retailer which supplied the wheelchair to you.

You can always find the latest version of the user manual and information on your product on our

homepage. For information or queries concerning product safety and on recalls, please contact DIETZ in writing or by telephone. You will find our contact information on the back of these operating instructions.

For reasons of better readability, the simultaneous use of the language forms masculine, feminine and diverse (m/f/d) is dispensed with in the following and the generic masculine is used. All personal designations apply equally to all genders.



HINWEIS

A large-print version of the operating instructions is available for visually impaired persons at **shop.dietz-group.de** in PDF format.



1 Important information

Intended purpose	6
Indications	6
Contraindications	7
Symbols	7

2 Product description

Scope of delivery	8
Accessories (optional)	8
Structure of the TOMTAR MR-S/MR-LG	9

3 Setting up the wheelchair

Preparing the wheelchair for use	10
3.1 Folding/unfolding the wheelchair.	10
3.2 Backrest upholstery.	11
3.3 Attaching the leg rests	11

4 Using the wheelchair

Using the wheelchair.	12
4.1 Getting in and out of your wheelchair.	12
4.2 Swivelling the side panels/armrests	14
4.3 Removing the side panels/ armrests	14
4.4 Folding up the foot plates	15
4.5 Swivelling and detaching the leg rests	15
4.6 Propelling and slowing down the wheelchair with the push rims.	16
4.7 Driving on gradients and uneven ground	17
4.8 Loading the wheelchair.	17
4.9 Parking brakes	18
4.10 Drum brakes for an attendant (optional)	19
4.11 Removing and attaching rear wheels	20
4.12 Transport	21
Transport of the wheelchair without user	21
Wheelchair as a car seat	22
Attaching the wheelchair restraint systems	23
Wheelchair user restraint system	24

5 Individual adjustments

Important information on adjustments	26
Tools	26
5.1 Lower leg length	26
5.2 Adjustable backrest (only TOMTAR MR-LG)	27
5.3 Armrests	27
5.4 Adjusting the push handle (only TOMTAR MR-LG)	28
5.5 Seat depth	28
5.6 Seat height adjustment	29
5.7 Parking brakes	30
5.8 Drum brake (optional)	30
5.9 Wheelbase extension (optional)	31
5.10 Anti-tipping supports (optional)	32
5.11 Angle-adjustable foot plates	32
5.12 Safety belt (optional)	33
5.13 Height-adjustable side panel (optional)	33
5.14 Amputee support (optional)	34
5.15 Brake lever extension (optional)	34
5.16 Therapy tray (optional)	35
5.17 Elevating leg rest (optional)	35
5.18 Accessories and add-ons from external suppliers	37

06 Technical data

Wheelchair dimensions	38
Technical specifications	39
Materials	40

07 Safety instructions

Safety information & driving restrictions	42
---	----

08 Instructions for general use

Servicing/maintenance	44
Maintenance schedule	45
Troubleshooting	47
Cleaning	48
Disinfection	48
Forwarding / reusing	49
Storage	49
Disposal	49
Product labelling	50

09 Manufacturer's declarations

Warranty	51
Lifetime	51
Liability	51

INTENDED PURPOSE

The wheelchair TOMTAR MR-S / MR-LG is only intended to be used to carry persons with a maximum bodyweight of 130 kg. It can be used indoors and outdoors.

Persons who use the wheelchair independently must be physically and mentally capable of moving and braking the wheelchair. The user must have sufficiently good eyesight to use the wheelchair in public spaces and to use public highways.

If the wheelchair is moved by an accompanying person, the accompanying person must be physically capable of pushing and braking the occupied wheelchair.

The wheelchair is not suitable for children. The wheelchair shall not be used for the transport of more than one person or of cargo.

The intended purpose may differ for products which were manufactured as custom-made device and which have been labelled as such. In this case, please refer to the documentation supplied with the product.

INDICATIONS

This wheelchair provides assistance for persons who are unable to walk or who have a severe walking impediment due to

- ▼ Paralysis
- ▼ Loss of limbs
- ▼ Limb defect/deformation
- ▼ Joint contracture/joint damage (not on both arms)
- ▼ Other diseases.

CONTRAINDICATIONS

Use of the wheelchair is unsuitable in the case of

- ▼ False sensations
- ▼ Severe disequilibrium
- ▼ Loss of limbs on both arms
- ▼ Joint contracture/joint damage on both arms
- ▼ Inability to sit
- ▼ Impaired or inadequate vision.

SYMBOLS

These symbols indicate passages of text that are helpful for using and operating the product in every day life.



WARNING

It is mandatory to observe and comply with warnings.

They inform you of circumstances that could result in injury and/or damage to the wheelchair or surroundings if the warnings are not observed.____



NOTE

Tips and advice to simplify using the functions. _____

The TOMTAR MR-S / MR-LG is delivered completely assembled and packaged in a box. If possible, please keep the packaging for possible later storage of the wheelchair.

SCOPE OF DELIVERY

On receipt of the wheelchair, please immediately check to make sure that the contents are complete and undamaged. The contents consist of:

- ▼ 1 set of cardboard box and packaging
- ▼ 1 pre-assembled wheelchair
- ▼ 1 pair of leg rests
- ▼ Operating instructions
- ▼ Multipurpose wrench (8, 10, 13, 16, 19 mm)
- ▼ Accessories (if selected)

ACCESSORIES (OPTIONAL)

Wheelchair accessories available from the manufacturer:

- ▼ Amputee support(s)
- ▼ Anti-tipping supports
- ▼ Safety belt
- ▼ Brake lever extension
- ▼ Wheelbase extension
- ▼ Height-adjustable side panel
- ▼ Therapy tray
- ▼ Angle-adjustable leg rests

STRUCTURE OF THE TOMTAR MR-S/MR-LG

Basic components

The overview represents all models and shows the most important components of the standard folding wheelchair. All illustrations show the standard TOMTAR MR-S wheelchair unless stated otherwise.

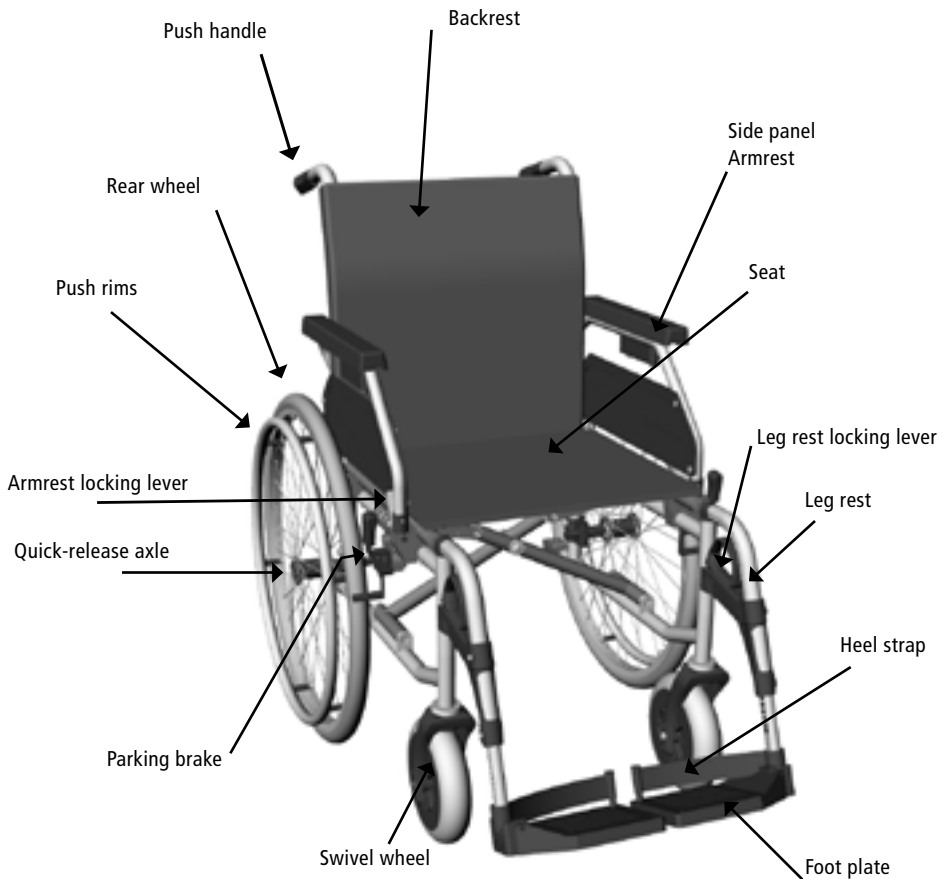

fig. 1

PREPARING THE WHEELCHAIR FOR USE

The following chapter contains information on how to unfold the wheelchair and prepare it for use. Before using the wheelchair for the first time, you need only to unfold the wheelchair, attach the leg rests and fix the Velcro backrest upholstery flap in place.

The chapter **“05 Individual adjustments”** contains explanations of all the more complicated adjustment options, such as the seat height, angles etc., that can be used for optimum adjustment.



NOTE

The initial set-up should be carried out by trained personnel of the medical supplies dealer.

3.1 Folding/unfolding the wheelchair

Unfolding the wheelchair

1. Tip the wheelchair slightly to one side (1, fig. 2).
2. On the opposite side, press the seat tube downwards as far as it will go (2, fig. 2).
3. Tip the wheelchair back and set it down.
4. Check whether the wheelchair has unfolded completely. To do so, press on the tubes on both sides of the seat

Folding the wheelchair

1. Fold up the foot plates or remove the leg rests. (Chapter 4.4 & 4.5)
2. Take hold of the front and back edges of the seat cover and pull the seat cover upwards in the middle (3, fig. 2). The wheelchair will then fold automatically.



fig. 2

3. Push back the backrest upholstery when folding the wheelchair.



fig. 3

3.2 Backrest upholstery

The flap (1, fig. 3) of the backrest upholstery can be fixed to the bottom of the seat pad with Velcro to close the gap between backrest and seat.

3.3 Attaching the leg rests

1. Insert the leg rest into the guide on the wheelchair from above (1, fig. 4). When doing so, the leg rest must be angled outwards. The foot plate must be folded up.
2. Swivel the leg rest forwards (2, fig. 4). You must hear and feel the leg rest engage.
3. Check that the leg rest is securely locked in place.
4. The footplates are folded down after the leg rests have been attached.



fig. 4

USING THE WHEELCHAIR

4.1 Getting in and out of your wheelchair

Different handicaps allow more or less manoeuvrability.

To get in and out of your wheelchair easily and safely, the following tips can be helpful.



NOTE

Place the wheelchair backwards against a stable wall (fig. 5). This ensures that the wheelchair will not roll away on smooth surfaces.

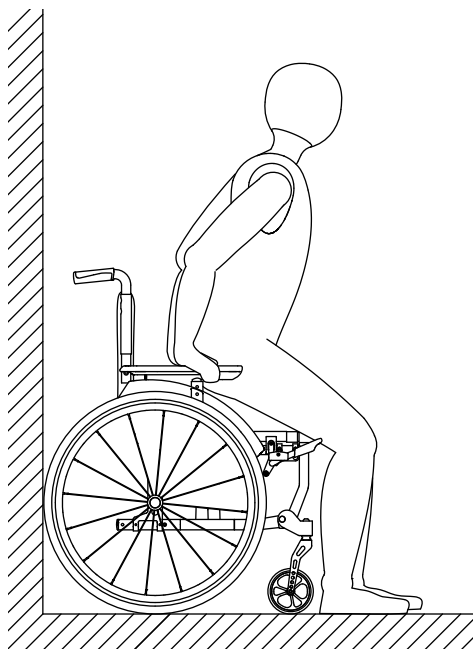

fig. 5

Getting into your wheelchair

Take off the leg rests (see chapter 4.5).

If possible, place the wheelchair's rear wheels against a solid wall.

Apply the parking brakes to lock the wheelchair in place.

Stand as close as possible to the wheelchair. Turn around, then carefully move backwards until your legs touch the edge of the seat.

Now grab the armrest with your hands.

You can now sit down slowly and safely.

Swivel both the leg rests back to the front in the direction of travel. Listen and feel for the click to ensure that the leg rests are correctly engaged.

Finally, fold both the foot plates downwards using your feet and place your feet on the foot plates (see chapter 3.3).

Getting out of your wheelchair

Carry the procedure out in the opposite sequence.



WARNING

Do not stand on the foot plates or footboard while getting up or sitting down. They are not intended to bear the full weight of one person. _____



NOTE

To transfer sideways, the side panel must be swivelled up (see chapter 4.2). _____

4.2 Swivelling the side panels/armrests

The side panels can be swivelled upwards/back along with the armrests to enable users to transfer onto or off the wheelchair from the side.

1. Press the side panel locking lever forwards (1, fig. 6).
2. Take hold of the side panel by the tube in front of the armrest and swivel the side panel upwards/back (2, fig. 6)

When swivelling the side panel downwards: Insert the tube of the side panel into the fixture and ensure that it engages correctly (3, fig. 6)



fig. 6

4.3 Removing the side panels/armrests

1. Swivel the side panel upwards/back (4.2).
2. Pull the rear pin on the clamping device downwards (4, fig. 7).
3. Grip the side part by the armrest and pull it back out of the holder (5, fig 7).

To reattach the side panel, perform these actions in reverse order.



NOTE

The rear mount must be guided into the fixture when inserting the side panel /armrest. Ensure that the locking pin audibly engages. _____



fig. 7

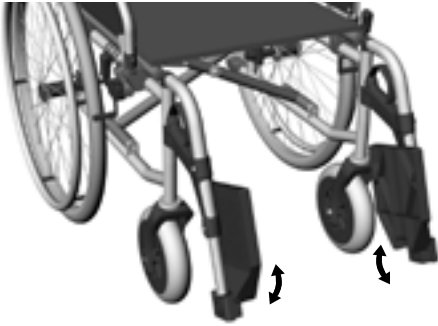

fig. 8

4.4 Folding up the foot plates

1. Take hold of the foot plate by the front edge.
2. Swivel the foot plate upwards. (fig. 8)



WARNING

The user must not put their weight on the foot plates when getting in and out of the wheelchair. _____

4.5 Swivelling and detaching the leg rests

The leg rests can be swivelled to the side and detached to make it easier to transfer onto or off the wheelchair. This also allows you to move the wheelchair closer to a bed or bathtub.

1. Fold the foot plate upwards (see chapter 4.4).
2. Pull the locking grip upwards (2, fig. 9)
3. Swivel the leg rest to the side (3, fig. 9).
4. If you wish to remove the leg rest: Take hold of the leg rest on the horizontal part of the tube and pull the leg rest upwards out of the guide (4, fig. 9)

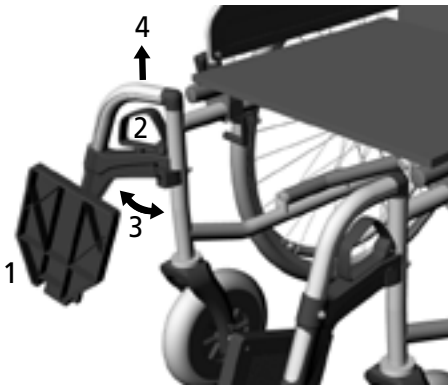

fig. 9



WARNING

When leg rests are swivelled outwards, they are automatically unlocked and can easily become detached from their mounts. Please be aware of this, e.g. during transport! _____

4.6 Propelling and slowing down the wheelchair with the push rims

The wheelchair is pushed and slowed down using the push rims. Grip the push rims with your hands with your thumbs pointing forwards on the push rims (see fig. 10).



WARNING

Ensure that your thumbs do not touch the tyre casing of the wheel whilst the wheelchair is in motion.

To propel the wheelchair forwards: Push both wheels forwards evenly.

To propel the wheelchair backwards: Push both wheels backwards evenly.

To stop the wheelchair: Close your hands around the push rims and gradually increase the pressure of your grip.

To steer to one side: Slow the wheel on the side to which you wish to turn.

To turn the wheelchair on the spot: Push one wheel forwards and the other wheel backwards at the same time.

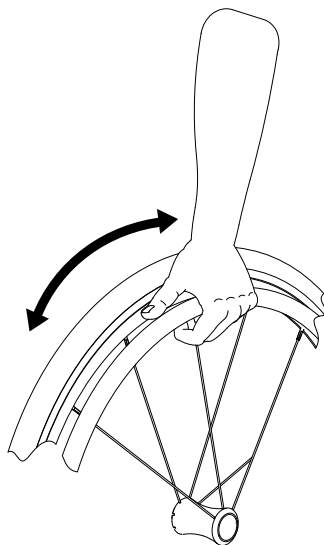

fig. 10



WARNING

Risk of trapping: Between the tyre and sideguard/armrest!



WARNING

During hard braking manoeuvres the push rims can become quite hot.

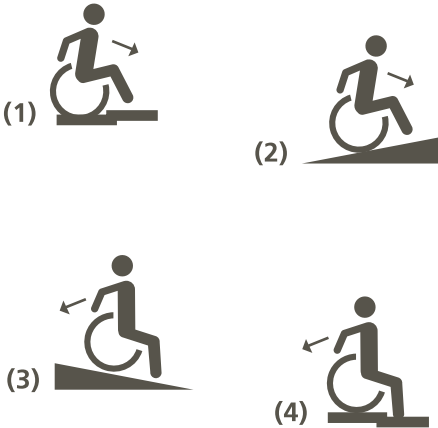

fig. 11

4.7 Driving on gradients and uneven ground

Potholes and uneven ground can cause the wheelchair to tip over when driving over ramps, slopes, gradients and kerbs.

Lean your body forwards when driving upwards over a step or slope. (1 & 2, fig. 11)

Lean your upper body further backwards when driving down slopes and steps. (3 & 4, fig. 11)



WARNING

Always drive up or down slopes/gradients in a straight line and at a reduced speed. Do not drive over slopes or gradients obliquely as this increases the risk of tipping over.



WARNING

If you brake the wheelchair for a long time using the handrims, e.g. when driving downhill, a lot of frictional heat is generated on the handrims. Wear suitable gloves.

4.8 Loading the wheelchair

Additional loads (backpacks or similar objects) up to max. 5 kg can be hung from the push handles as long as the max. user weight is not exceeded.



WARNING

Hanging loads on the wheelchair increases the risk of it tipping over backwards.

That is why DIETZ recommends using anti-tipping supports.

4.9 Parking brakes

The wheelchair has one parking brake on either side. They can be used to park the wheelchair safely.

1. Press the brake lever forwards so that the brake blocks the wheel (1, fig. 12).
2. Press the brake lever further forwards until you feel it engage (2, fig. 13).

To release the parking brake: Pull the brake lever backwards.

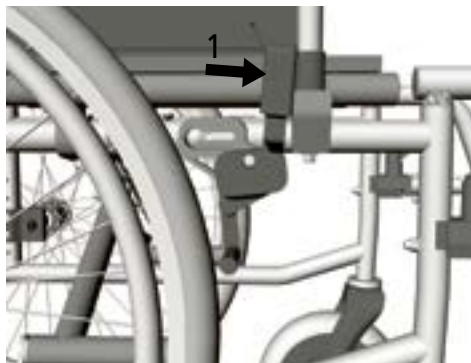

fig. 12

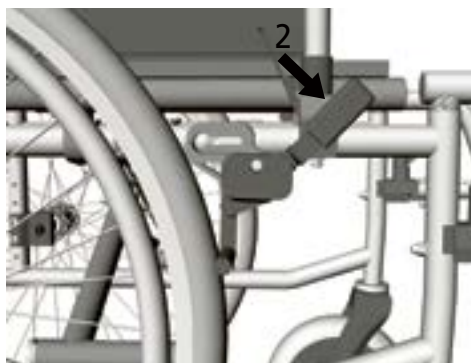

fig. 13



WARNING

Do not use the parking brakes to stop the wheelchair during motion as this may cause the wheels to block. Due to the immediate locking of the wheels, you may no longer be able to control the direction of travel.



NOTE

Use both parking brakes when parking the wheelchair. This ensures that the braking force is evenly distributed on both rear wheels.



fig. 14

4.10 Drum brakes for an attendant (optional)



WARNING

In models without drum brakes, the accompanying person must be physically capable of braking the wheelchair by themselves.

The wheelchair is optionally available with drum brakes for an attendant. The drum brakes enable the wheelchair to be slowed in a controlled manner while in motion. The drum brakes can also be used as additional parking brakes.

Stopping the wheelchair:

Pull evenly on both brake levers (1, fig. 14).

Parking the wheelchair:

1. Pull on both brake levers (1, fig. 14).
2. Push the safety catch away from yourself until it engages (2, fig. 14). The drum brake is now locked.



NOTE

If the drum brakes are locked, it must not be possible to push the wheelchair.

Releasing the parking brake: Pull the brake levers gently. The lock will be released.

4.11 Removing and attaching rear wheels

It can be useful to remove the rear wheels when transporting the wheelchair or making adjustments.

Removing a rear wheel:

1. Use your thumb to press the lock button of the quick-release axle in the centre of the wheel hub (1, fig. 15).
2. Put your other fingers between the spokes.
3. Pull the rear wheel with the quick-release axle out of the axle holder (2, fig. 15).

Attaching a rear wheel:

1. Use your thumb to press the lock button of the quick-release axle.
2. Position the rear wheel on the wheelchair and insert the quick-release axle into the mount until it engages.
3. Check whether the quick-release axle is correctly engaged.



WARNING

After attaching the wheels, always verify that the lock has engaged correctly. _____



fig. 15



NOTE

If you hold down the lock button when attaching the rear wheels it is easier to insert the quick-release axle in the mount. _____

4.12 Transport

Transport of the wheelchair without user

To transport the wheelchair in a car, airplane, train or simply to create space, the wheelchair can be folded and separated into portable elements without any tools. It then only takes up a very small amount of room and is easy to store. Please check that the packing dimensions comply with the transportation requirements of the respective airline/railway company.

TOMTAR MR-S folded W/L/H in mm = 310 / 945 / 800

TOMTAR MR-LG folded W/L/H in mm = 310 / 945 / 800

Please pay attention to the following points when transporting the wheelchair without a user:

1. Fold the wheelchair for transport. (Chapter 3.1)
2. Carry the folded wheelchair by holding the front of the side frame and the push handles.
3. Remove any components that can easily come free from the wheelchair (e.g. leg rests, accessories) and store them safely.
4. Lash the unoccupied wheelchair securely in place.
5. The wheelchair must not be loaded during transport.
6. The wheelchair can be transported upright with and without rear wheels. (Chapter 4.10 - Removing and attaching rear wheels)
7. The wheels must be kept attached to the wheelchair if it is transported lying on its side.
8. Activate the locking brakes when transporting the wheelchair with rear wheels.



NOTE

To set up the wheelchair, follow the operating instructions in chapter "03 Setting up the wheelchair". _____

Wheelchair as a car seat

Wheelchairs are not designed to be used as car seats and cannot provide the same level of safety as a regular seat in a car, no matter how well the wheelchair is fastened in the respective vehicle. DIETZ therefore recommends to seat wheelchair users on regular vehicle seats whenever possible.

The TOMTAR MR-S/MR-LG wheelchair complies with ISO 7176-19 and is therefore suitable for use as a seat for transporting passengers in motor vehicles. It accordingly is labelled in line with ISO 7176-19.

Tests were conducted using a H3 50% dummy (78 kg) and a headrest.

Passenger cars designed for transporting wheelchair users while seated in a wheelchair have to have a wheelchair space in accordance with the German Road Traffic Licensing Regulation (StVZO). All wheelchair spaces in a vehicle have to be provided with a wheelchair and wheelchair occupant restraint system capable of restraining the wheelchair and its occupant. The vehicle owner and driver must provide in-car restraint systems that comply with the ISO 10542 standard and ensure that they are used correctly.



WARNING

Failure to observe these instructions can result in severe bodily injury and danger to life! _____



ISO 7176-19
Crash-tested label



fig. 16



WARNING

Always ask the carrier whether the respective vehicle is designed, insured and equipped to carry a person in a wheelchair.. _____

Attaching the wheelchair restraint systems

Only a 4-point wheelchair restraint system with lashing straps that is certified in line with ISO 10542 and designed for the total weight of the wheelchair must be used to secure the TOMTAR MR-S/ MR-LG without a power hub.

The 4 lashing strap anchor points on the wheelchair are labelled with a hook symbol (see example in illustration (A) and (B)). All 4 anchor points must be used. It is mandatory to position the wheelchair in the direction of travel in line with ISO 10542 (WTORS). Under no circumstances must the wheelchair be strapped in place using other attachment points (e.g. anti-tip bar, armrests). No modifications must be made to the transport anchor points of the wheelchair without the permission of DIETZ.

The wheelchair restraint system must be installed in the vehicle in line with the manufacturer's assembly instructions.

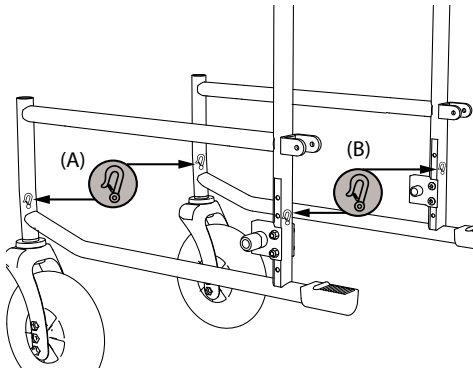

(A) Front anchor points on the wheelchair

(B) Rear anchor points on the wheelchair

fig. 17



WARNING

The TOMTAR MR-S/ MR-LG is tested in line with the ISO standard 7176-19 / ISO 10542 in the direction of travel. For reasons of safety, it must not be used/attached with the wheelchair user facing away from or sideways to the direction of travel.

Wheelchair user restraint system

First attach the wheelchair restraint system. Next, the wheelchair user is secured using a suitable restraint system in line with ISO 10542.

When doing so, the following must always be ensured:

- ▼ Fasten the shoulder and lap belt. Both of these belts must be fastened quite tightly, but not so tight as to cause discomfort to the wheelchair user and must not be twisted.
- ▼ The upper part of the safety belt must run across the torso and shoulder/collarbone.
- ▼ The lap belt must run at an angle of 30° to max. 75° from the horizontal but under no circumstances greater than 75° (fig. C).
- ▼ Safety belts must not be routed over components of the wheelchair, such as armrests or wheels, which would hold it away from the body. (fig. D).
- ▼ Only products that are certified in line with ISO 7176-19/ISO 10542 or DIN standard 75078 and appropriately identified by their manufacturer may be used as restraint systems.
- ▼ The wheelchair's parking brakes must be fully engaged throughout the drive.



WARNING

The geometry of the anchor points (or of the attachment system) must be adjusted with the same precision as the user's straps to ensure safe transport in a vehicle with a user seated in the wheelchair. Non-observance of these requirements can put the wheelchair user's life at risk in the event of an accident.

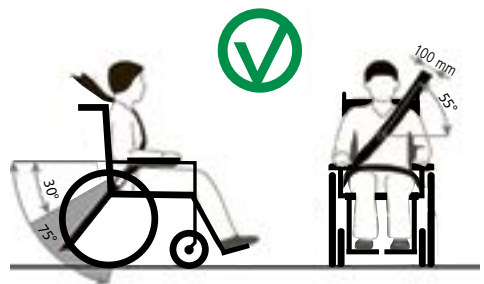

(C) Correct attachment of the safety belts

fig. 18

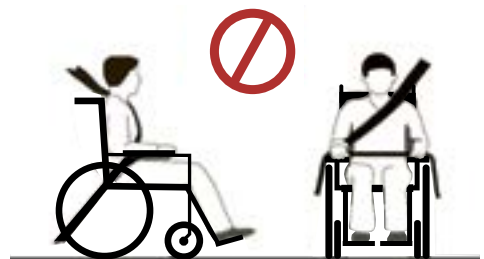

(D) Wrong way to attach the safety belts

fig. 19



WARNING

A therapeutic headrest provided on the wheelchair serves to support the head posture during regular operation and cannot replace a car suitable headrest for use in a motor vehicle. _____

- ▼ Remove any components that can easily come free from the wheelchair, such as a therapy tray or walking aids etc., before beginning the journey. Keep them in a suitable safe place.
- ▼ Swivelling/adjustable-height leg rests must not be raised when the user is being transported whilst seated in the wheelchair and the wheelchair is secured by a restraint system and safety belt.
- ▼ Adjustable backrests must be put in the upright position.
- ▼ The wheelchair user's safety during transport depends on the care with which the restraint system has been secured. The person having secured the restraint system must be trained or instructed in the use of the system.

Wheelchairs that have been involved in an accident must be checked by a DIETZ service technician before any further use.

IMPORTANT INFORMATION ON ADJUSTMENTS

Accessories are sometimes required for the settings described below. Only original accessories from DIETZ may be used. Only then is the compliance and thus the safety of the product guaranteed.

When setting up a new user for the first time, all wheelchair adjustments must be carried out by qualified specialists so that correct positioning and safety can be guaranteed.

Tools

Tools are required for some of the individual setting tasks and checks on the TOMTAR MR-S/MR-LG:

Allen key sizes 4, 5 & 6
Open-end wrench AF 10
cross tip screwdriver (size 2)



WARNING

Complex adjustment tasks that can result in a risk of accident if not performed correctly must only be conducted by designated specialist staff and are labelled accordingly. "Only to be performed by specialist staff"

This particularly applies to adjusting the brakes and for settings that affect the stability of the wheelchair.

5.1 Lower leg length

1. Loosen the bottom screw joint on the leg rest (1, fig. 20) by one rotation.
2. Grip the footplate and pull it down or push it up until the desired position is reached (2, fig. 20), but not above the max./min. label.
3. Tighten the threaded connection securely again (1, fig. 20).
4. Check whether the lower leg length is correctly set: The thighs must be horizontal when the feet are placed on the foot plates.



fig. 20



fig. 21

5.2 Adjustable backrest (only TOMTAR MR-LG)

The TOMTAR MR-LG is equipped with a Velcro adjustable backrest as standard. It can be adjusted to suit your requirements. (fig. 21)

To do so, open the back strap's Velcro fastener under the seat pad and fold it forwards along with the backrest upholstery. Now release the Velcro strap (1). Then you can Velcro (1) the straps together in the desired position (2). The Velcro strap must overlap by at least 10 cm. Start with the lowest strap. Finally, fold the back strap backwards again and fasten it in place using the Velcro fastener.

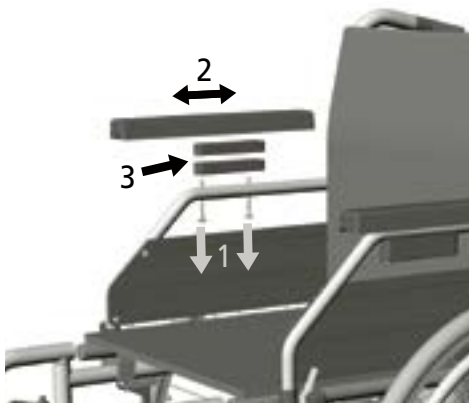

fig. 22

5.3 Armrests

The length and height of the armrests can be adjusted. (fig. 22)

1. From below, loosen the two Phillips screws with which the armrest is attached to the side panel. (1)
2. Adjusting the length (100 mm): Slide the armrest backwards or forwards using the threaded inserts provided (adjustable in 25-mm stages). (2).
3. Adjusting the height (30 mm): Remove the armrest and insert one or both height adapters (15 mm) between the tube of the side panel and the armrest (3).
4. Attach the armrest with the two Phillips screws.

5.4 Adjusting the push handle (only TOMTAR MR-LG)

On the TOMTAR MR-LG, the height of the push handle can be adjusted to suit the requirements of the accompanying person.

1. First, loosen the clamping lever screw on the back of the backrest. (1, fig. 23).

2. Now you can pull the tube of the push handle up into the desired position. (2, fig. 23).

Screw the clamping lever screw back into one of the three bores provided. Ensure that the clamp lever screws are tight.



fig. 23

5.5 Seat depth

The wheelchair is delivered with the maximum possible seat depth of 440 mm. To reduce the depth of the seat, first remove the leg rests (see chapter 4.5). Next, open the Velcro straps on the left and right under the seat pad (1, fig. 24).

Now attach the Velcro straps to the bottom of the seat pad extension so that they no longer enclose the wheelchair frame (2, fig. 25). Fold the extension under the seat and fasten the Velcro straps to secure it there (3, fig. 25).

Carry the procedure out in the opposite sequence to increase the seat depth.



fig. 24

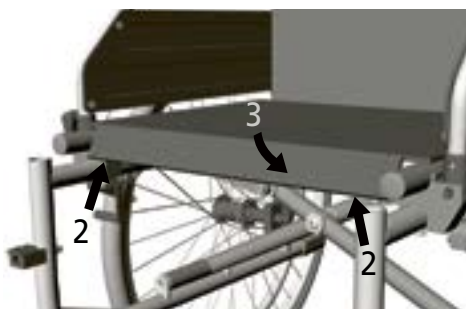

fig. 25



fig. 26



fig. 27

5.6 Seat height adjustment

Only to be performed by specialist staff:

The wheelchair is delivered with the seat at a height of 510 mm. Alternative seat height settings of 485 mm and 460 mm can be selected using bore holes in the wheel forks and the wheelchair frame.

Tools: Allen key size 6 and open-end wrench AF 10

Holes to be used in the front wheel fork (1, fig. 26).

1. Seat height 51 > Lower bore hole in the wheel forks
2. Seat height 48.5 > Middle bore hole in the wheel forks
3. Seat height 46 > Upper bore hole in the wheel forks

The wheelchair frame has 5 bore holes for seat height adjustment using the rear wheel adapter (2, fig. 28). Bore holes provided:

4. Seat height 51 > 2nd + 3rd hole from the bottom
5. Seat height 48.5 > 3rd + 4th hole from the bottom
6. Seat height 46 > 4th + 5th hole from the bottom

To do this, loosen the fastening screws of the rear wheel adapter (2, fig. 27) and adjust it to the desired height. Tighten the screws again.



WARNING

Ensure that all screws have been tightened after the adjustments have been made. _____



WARNING

Altering the seat height means the parking brakes will have to be readjusted (see chapter 5.7). _____

5.7 Parking brakes

Only to be performed by specialist staff:

The distance between the brake pins and the tyre casing must be 3-5 mm at the narrowest point when the brake mechanism is fully open (1, fig. 28).

Tools: Allen key size 4 and open-end wrench AF 10. Loosen the screw to adjust/correct the distance (2, fig. 28). Then push the brakes into the correct position. Now retighten the screw and check the function of the brakes. When the brakes are applied, it must not be possible to push the wheelchair.

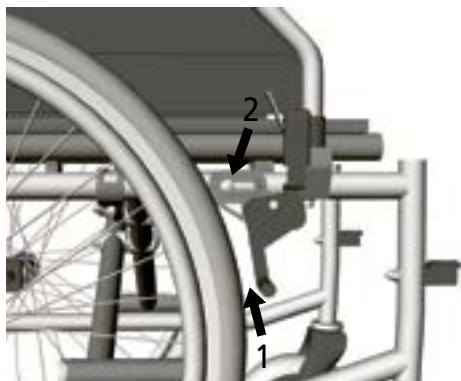

fig. 28

5.8 Drum brake (optional)

Only to be performed by specialist staff:

Adjust the braking force using the adjusting screw (1) on the brake cable to achieve an optimum braking effect. (fig. 29)

Tools: Open-end wrench AF 10

Increase the braking force by unscrewing the adjusting screw (1). Loosen the lock nut and unscrew the adjusting screw until you hear grinding noises from the turning wheel. Then screw in the adjusting screw until the grinding noises stop. Once you have finished adjusting the settings, the adjusting screw is fixed by tightening the lock nut.



fig. 29



WARNING

Ensure that the drum brakes are evenly adjusted on both sides of the wheelchair. _____

5.9 Wheelbase extension (optional)

Only to be performed by specialist staff:

Moving the rear wheel backwards extends the wheelbase and therefore improves the stability of the wheelchair.

Tools: Allen key size 4 and open-end wrench AF 10.

If the wheelbase is extended, the parking brake must be modified to ensure that the distance between brake pin and tyre casing is 3-5 mm at the narrowest point as intended.

First, remove the rear wheels (see chapter 4.12). This secures the wheelchair against tipping over. Next, loosen the two screw joints of the adapter (1, fig. 30) and pull the screws out completely. Then, rotate the adapter vertically by 180° (2, fig. 30, 31) and fix it in place. Ensure that all screws are firmly tightened.

On the model with the drum brake, the brake cable must be detached before dismantling the adapter. After, the adapter including the drum brake is rotated vertically by 180°. After mounting the adapter, the brake cable must be correspondingly relocated and fixed in place again.

To modify the parking brake as necessary, first remove the locking brakes.

Then, swap the mounting bracket of the parking

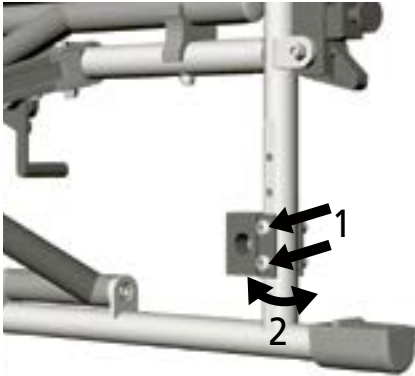

fig. 30



fig. 31



WARNING

Converting the wheelbase means all brakes will have to be readjusted (see chapter 5.7 and 5.8). __

brake from one side to the other side and rotate it horizontally by 180°. (1, fig. 32).

The assembly retainer (2, fig. 33) is now positioned to the rear (180° horizontal). Next, mount the parking brake on the wheelchair.

Please make sure that the parking brakes are correct adjusted. (see chapter „Parking brakes“)

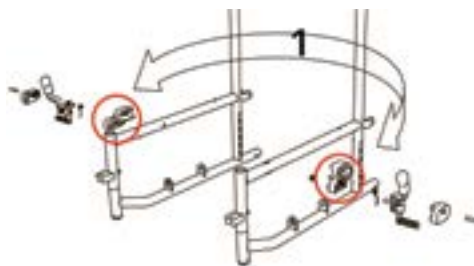

fig. 32

5.10 Anti-tipping supports (optional)

Only to be performed by specialist staff:

(fig. 34) Tool: Open-end wrench AF 10

Remove the rubber tilting aids to insert the attachable anti-tipping supports in the lower rear frame tube (1). The supporting wheels are attached to the metal tube and secured with a screw (2).

The height of the wheels can be adapted to the wheelchair and the anti-tipping supports can be pushed upwards. This is useful if an accompanying person is pushing the wheelchair and needs to get past obstacles. To do so, pull the red clamp bracket towards yourself (3) and push the tube up or down (4) along the fixture.

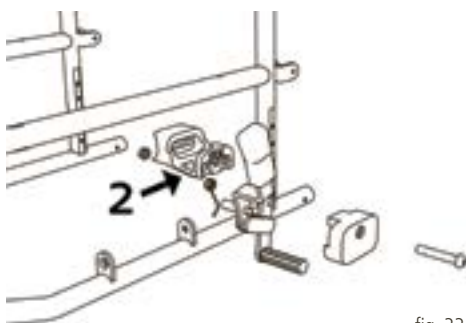

fig. 33

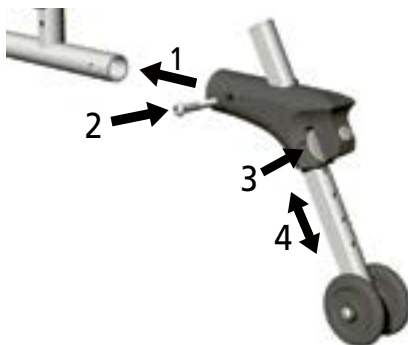

fig. 34

5.11 Angle-adjustable foot plates

Tools: Allen key size 5

To change the angle, first loosen the Allen screw (1, fig. 35) and pull the foot plate slightly inwards until the lock is released. Now adjust the foot plate to the desired angle (2, fig. 35) then tighten the Allen screw again.

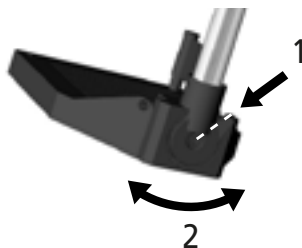

fig. 35

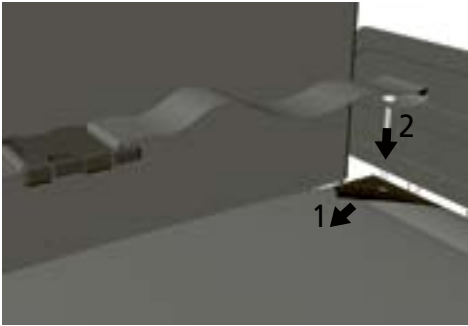

fig. 36

5.12 Safety belt (optional)

Only to be performed by specialist staff:

An optional belt can be installed. This secures and stabilises the person seated in the wheelchair. It prevents the person from tipping forwards out of the wheelchair.

Tools: Cross tip screwdriver

The safety belt is attached to the most rear screw connection of the seat pad. To do so, loosen the Velcro on the side of the seat pad (1, fig. 36). Now you can loosen the back screw on the seat pad. Position the end of the lap belt with the eye precisely over the bore hole in the seat pad. Now screw the seat pad and the lap belt together (2, fig. 36) using the screws supplied with the lap belt. Ensure that the screw has been tightened.

5.13 Height-adjustable side panel (optional)

To replace the side panel, proceed as described for the standard side panel in the chapters “Removing the side panels/armrests” and “Swivelling the side panels/armrests”.

You can adjust the armrest height using the external push button (1, fig. 37) by adjusting the height while pressing the push button. The armrests can be adjusted to 8 heights in 1-cm steps from 230 mm to 300 mm above the seat’s surface. The length of the armrest pad is 305 mm measured from the back frame.



fig. 37

5.14 Amputee support (optional)

1. Remove the leg rest (chapter 4.5).
2. Grasp the amputation board by the cushion and insert it from above into the frame tube (1, fig. 38).

Adjusting the amputee board angle:

1. Release the clamping lever counterclockwise (2, fig. 38).
2. Move the amputee board into the desired position.
3. Tighten the clamping lever in a clockwise direction.



fig. 38

Adjusting the height of the amputee board:

1. Loosen the two socket head screws (3, fig. 38).
2. Take hold of the amputee board by the pad and push it upwards or downwards until the desired position has been achieved. Finally, tighten the screws again.

5.15 Brake lever extension (optional)

To be performed by a specialist dealer: The brake lever extension is used to make it easier to transfer force to the brake. (fig. 39)

1. Remove the standard brake lever by pulling it upwards (1). The mounting hole for the brake lever extension can now be seen.
2. Attach the brake lever extension to the exposed mounting hole using a Phillips screwdriver and a size 10 open-end wrench.

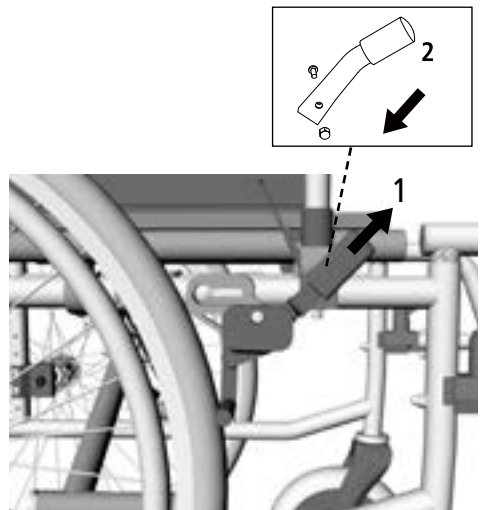

fig. 39

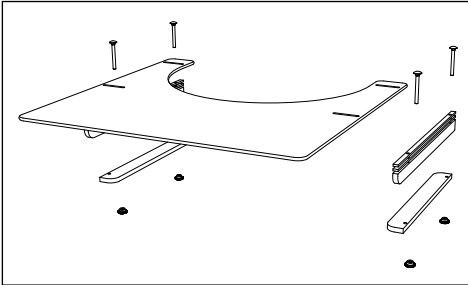

fig. 40

**WARNING**

Risk of trapping: there is a risk of trapping on moving parts (e.g. calf pad, pivot lever)

Risk of injury: do not stand on the foot plate or carry the wheelchair by the leg rests. They are not intended to bear the full weight of one person. —

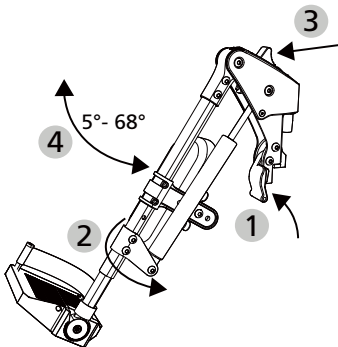

fig. 41

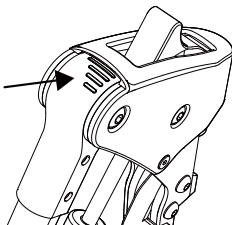

fig. 42

5.16 Therapy tray (optional)

The therapy tray is mounted using a set of rails. For further information, see the assembly instructions delivered along with the therapy tray.

5.17 Elevating leg rest (optional)

The calf pad have to be installed before using for the first time. Use the enclosed 5 mm Allen screw and nut and install in the third position hole on the calf pad holder (see 5, fig. 43/ fig. 44 s. 36/37).

When attaching the leg rest to the wheelchair, proceed in the same way as with a standard leg rest (see the wheelchair user manual). To fold the leg rest, move the locking lever forwards whilst rotating the leg rest to the side (1/2, fig. 41).

Adjusting the angle of the leg rest 5°- 68°

1. Press the release lever for the pneumatic spring forwards (3/4, fig. 41). The knee angle falls from 68° to 5° as long as the release lever is kept pressed.
2. To set an angle, let the release lever of the pneumatic spring go at the desired position.
3. The grid lines can be used as an orientation for the set angle (fig. 42).
4. Press the release lever forwards and push the leg rest down at the same time to increase the knee angle (fig 41).

Adjusting the lower leg length:

1. To adjust the length, loosen the Allen screw 4 mm (A, fig. 43) by a few rotations (1, fig. 43), but do not loosen it fully.
2. Then pull/slide the foot plate to the desired length (2, fig. 43). Pay attention to the minimum gap of 40 mm between the foot plate and the ground.
3. To lock it in place, tighten the screw (A, fig. 43) again firmly. Make sure that the screw engages in the interior carriage.

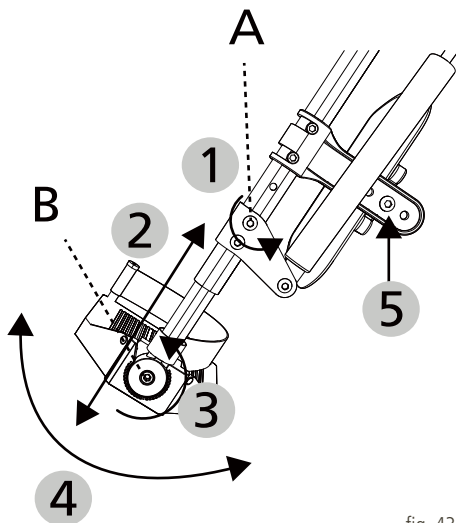

fig. 43

Adjusting the foot plate angle:

1. Loosen the Allen screw 5 mm (B & 3, Fig.55).
2. Pull the foot plate off on the inside.
3. Re-insert the foot plate at the desired angle (4, fig. 43).
4. Finally, fasten the foot plate in place again with the Allen screw B.

Positioning the calf pad:

5. Loosen the 2 Allen screws 5 mm on the holder to adjust the height. Following adjustment, fix the screws back into the hole pattern in 30 mm steps (1, fig. 44).
6. Loosen the Allen screw 5 mm to enable depth adjustment. Following adjustment, fix the screws back into the hole pattern in 20 mm steps (2, fig. 44).

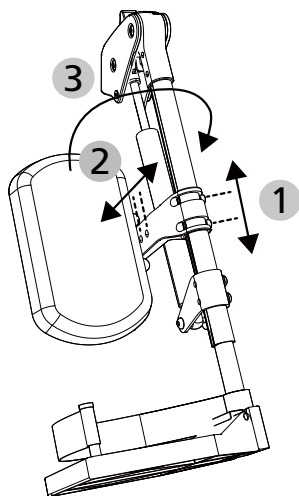

fig. 44



WARNING

The calf pad can be swivelled outwards with the holder to relieve the calf and give the leg more room (3, fig. 44).



WARNING

Should add-ons or accessories that are not sold by DIETZ are used, the safety of the product can not be guaranteed.

If accessories or add-ons are added to the wheelchair, then the safety instructions in the operating instructions for the accessories or add-ons must be observed. _____

5.18 Accessories and add-ons from external suppliers

In general only original accessories from DIETZ may be used. If third-party products are installed on the wheelchair, responsibility for the safety of the product passes to the person who installs the accessories or carries out the installation.

The compliance of the combination of accessories or add-on and product is then new, and must be declared by the person who attaches it. The compliance declared by DIETZ according to MDR 2017/745, Annex II expires.

WHEELCHAIR DIMENSIONS

The dimensions given here refer to the standard configuration of the wheelchair and may vary depending on the wheelchair model and configuration.

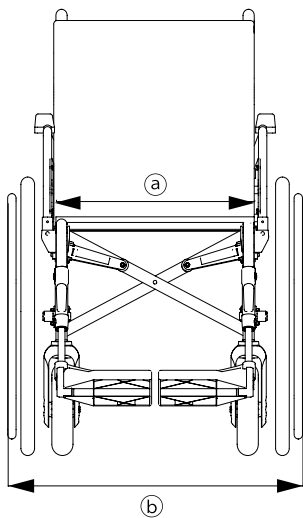

NOTE

All dimensions taken on textile parts (e.g. back upholstery) are to be understood with a tolerance of ± 1 cm.

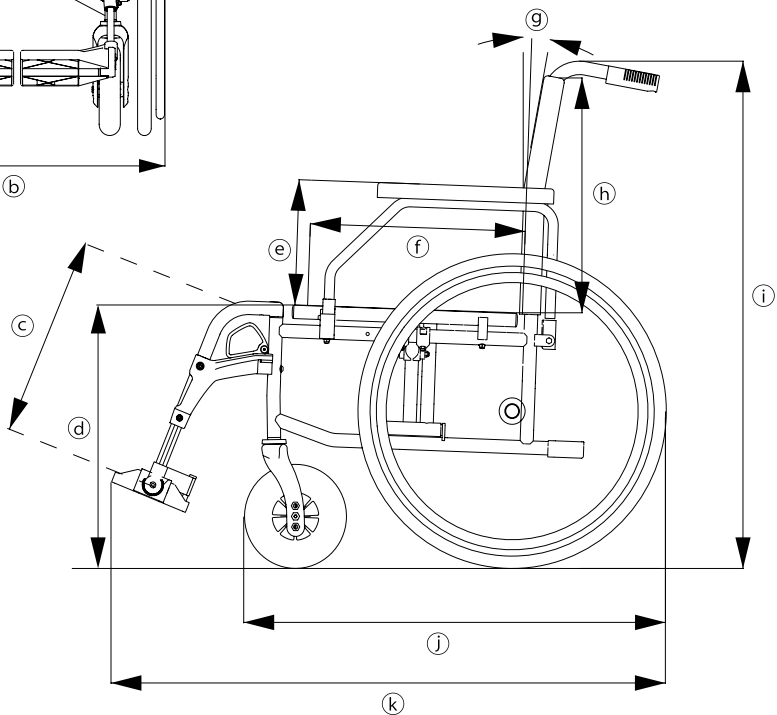

fig. 45

Technical specifications			TOMTAR MR-S		TOMTAR MR-LG	
			Min.	Max.	Min.	Max.
k	Total length with leg rests	mm	1052	1108	1052	1108
j	Total length without leg rests	mm	800		800	
b	Total width ¹	mm	590/620/650/680/710		590/620/650/680/710	
i	Total height	mm	945		945	1030
j	Length folded	mm	800		800	
	Width when folded	mm	310		310	
i	Height folded	mm	945		945	1030
	Total mass	kg	18.1	20.3	15.2	16.5
	Total weight with drum brake	kg	19.2	20.5	16.2	17.1
	Mass of the heaviest part ²	kg	10.8	12.0	8.2	9.5
	Static stability downhill ³	°	16		16	
	Static stability uphill ³	°	17		17	
	Static stability sideways ³	°	15		15	
	Seat plane angle °	°	2		2	
f	Effective seat depth (adjustable)	mm	400 (450)		400 (450)	
a	Effective seat width	mm	395-515		395-515	
d	Seat surface height (front edge) ⁴	mm	460 / 485 / 510		460 / 485 / 510	
g	Backrest angle	°	2		2	
h	Backrest height	mm	430		390-480	
c	Footrest to seat distance	mm	362	512	362	512
	Leg rest angle relative to seat	°	110		110	
e	Armrest to seat distance (adjust.)	mm	220 (235/250)		220 (235/250)	
	Armrest length from back frame	mm	280	380	280	380
	Push rim diameter	mm	525		525	
	Horizontal position of axle	mm	-30	30	-30	30
	Minimum turning radius	mm	1270	1290	1292	1312
	Maximum user weight ⁵	kg	130		130	

¹ The total width of 71 cm exceeds the recommended dimension of 70 cm stipulated by DIN EN 12183.

² Wheelchair weight minus removable parts (here without rear wheels, without side panels, without leg rests)

³ The static stability indicates the wheelchair's tipping resistance on slopes and gradients.

⁴ The seat height is measured according to ISO 7176-7 at the center of the front edge of the textile seat covering.

⁵ Maximum user weight including load/The weight of the load reduces the maximum user weight.

Technical specifications			TOMTAR MR-S		TOMTAR MR-LG	
			Min.	Max.	Min.	Max.
Tool number		18.50.02.0129		18.50.02.2131		
Wheelchair frame colour		Manganese grey metallic		Manganese grey metallic		
Seat width	mm	390/420/450/480/510		390/420/450/480/510		
Arm cushion (L x W)	mm	34 x 4.5		34 x 4.5		
Push handle height ⁶	mm	920-940		920-1025		
Rear wheels (Ø outer x B)	"	24 x 1 3/8		24 x 1 3/8		
Front wheels (Ø outer x B)	"	7 x 2		7 x 2		
Steepest slope on which parking brakes can be used	°	7		7		
Leg rest mass	kg	0.89	0.94	0.89	0.94	
Rear wheel mass	kg	1.85	2.09	1.85	2.09	
Side panel mass	kg	0.94		0.74		

⁶ The push handle height depends on the seat height setting. The MR-LG also has a height-adjustable push handle.

Note: Depending on the model/configuration, the wheelchair can exceed the recommended total dimensions as stipulated by DIN EN 12183.

Components	Materials	
	TOMTAR MR-S	TOMTAR MR-LG
Frame, backrest tubes	Steel, powder coated	Aluminium, powder coated
Seat/back upholstery	PU foam, PVC-coated polyester fabric	
Armrests	PU foam	
Cross brace	Steel	Aluminium
Screws, joints	Galvanised or burnished steel	
Tyres on rear/front wheels	PU plastic	
Therapy tray	Acrylic glass	
Leg rests	Aluminium, plastic	Aluminium, plastic

Note: All metals used are corrosion-resistance.

Further information	TOMTAR MR-S	TOMTAR MR-LG
Ambient operation temperature	-10 C° to +50 C°	
Ambient storage conditions	0°C to 45°C 20% to 75% relative humidity	
Test dummy weight	130 kg	
Crash test dummy	H3 50% dummy (78 kg)	
<p>Product tests: The TOMTAR MR-S and MR-LG fulfils the requirements of the international standards:</p>		
DIN EN 12183	the standards for manual wheelchairs have been tested	
ISO 7176-8	the static load capacity, shock resistance and fatigue strength have been tested	
EN 1021-2	resistance to inflammation has been tested for upholstery materials and plastic components	
ISO 10993-5	tested for toxicity in the material	

SAFETY INFORMATION & DRIVING RESTRICTIONS

When using the wheelchair, always observe the following safety information to prevent falls, hazardous situations and damage to the wheelchair:

- ▼ Before using the wheelchair for the first time, practice moving on level, clearly laid out terrain. Intensively familiarise yourself with its braking and acceleration behaviour when moving straight ahead and on cornering. An accompanying person is recommended.
- ▼ Never leave children or adolescents in the wheelchair without supervision.
- ▼ Always lock the brake before you sit down or get up from the wheelchair.
- ▼ Never use the wheelchair under the influence of alcohol or other substances which influence attentiveness or physical and mental receptiveness.
- ▼ Please note that the risk of tipping can increase if the balance is shifted due to bodily movements or placing loads on the wheelchair. Adjusting the wheelchair settings to their extremes increases the risk.
- ▼ With an incline / slope of more than 10° there is an increased risk of tipping backwards or forwards, DIETZ recommends using anti-tipping supports.
- ▼ Anti-tip supports must be used for wheelchair configurations that are prone to tipping even on gradients/inclines of less than 10°. They must be properly mounted.
- ▼ The use of ramps is essential for any obstacles.
- ▼ If they cannot be bypassed, ruts, rails or similar obstacles must always be crossed at right angles (90°).
- ▼ Do not propel your wheelchair forward against kerbs, edges or other obstacles without braking.
- ▼ Do not jump from obstacles (edges, steps etc.) while sitting in the wheelchair.
- ▼ Do not stand on the foot plates or footboard while getting up or sitting down.
- ▼ Observe the road traffic regulations when moving in road traffic.
- ▼ Wherever possible, wear light, eye-catching clothing. You will then be seen more easily by other road users.



- ▼ Avoid exposing the wheelchair to direct sunlight / low temperatures for long periods of time, as parts of the product (eg frames, footrests, brakes and side panels) may become very hot ($> 41^{\circ}\text{C}$) or very cold ($<0^{\circ}$) and may cause skin injuries.
- ▼ Always remember that there is a risk of fingers or other parts of the body getting caught in any of the moving parts (brakes, leg rests etc.) while the wheelchair is stationary or when it is moving. For this reason, operate the wheelchair with care.
- ▼ Ensure that the wheelchair is not parked in direct vicinity of emergency exits and escape routes and blocks them.
- ▼ Never exceed the max. load for driver and stowed objects as this can lead to injury or damage to the chair.
- ▼ Avoid escalators. The risk of falling and injury is significantly higher.
- ▼ Stairs must only be negotiated with the help of accompanying persons if no elevators or ramps are present.
- ▼ Never lift the wheelchair with occupants by the wheels or legrests, if necessary only by the fixed components such as the side frame.
- ▼ Any severe incidents associated with the product must be reported to the manufacturer and responsible authority.
- ▼ Protect the wheelchair and its materials against direct sunlight, excessively cold or warm temperatures and excessively high or low humidity if the wheelchair is stored for longer periods.
- ▼ The wheel bearings can be damaged by sand, seawater and road salt. The wheel bearings and the product can be damaged by sand, seawater and road salt. Clean the wheelchair thoroughly if it has been exposed to conditions such as these.
- ▼ If redness, irritation of the skin occurs in connection with the use of the product, consult a doctor immediately.
- ▼ If your product is custom-made (see product labelling), the additional documentation including all safety instructions must be observed in addition to the current operating instructions.

SERVICING/MAINTENANCE

We recommend performing the inspections listed in the maintenance schedule at regular intervals to ensure that the wheelchair is always safe to use.

Defective or neglected care and maintenance of the wheelchair limits liability. The maintenance schedule does not give any information concerning the amount of work actually required on the wheelchair.



NOTE

As the user, you will be the first to notice possible damage. If you notice a fault as described in the maintenance schedule or further defects and functional impairments, contact an authorised specialist dealer immediately. _____



NOTE

The inspections and measures stipulated in the maintenance schedule must be performed by the user or assistant if not otherwise stated. _____



WARNING

Repairs on the wheelchair must only be performed by specialist shops using DIETZ original spare parts to maintain the operational safety of the wheelchair. The relevant service manual and spare parts catalogue can be found on our website in the information of the product in question. _____



NOTE FOR SPECIALIST DEALERS:

If the user indicates abnormalities on the wheelchair, check all the inspection points listed in the maintenance schedule on the wheelchair. The checks must also be performed before putting the wheelchair back into operation and after longer storage periods (> 4 months). _____







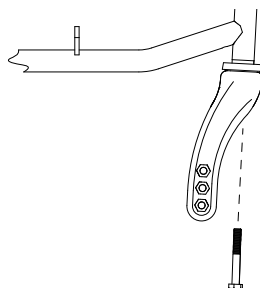

Abb.46

MAINTENANCE SCHEDULE

What	Description	Monthly	
		Daily / before using	
Parking brakes Check for correct function	<ul style="list-style-type: none"> The wheels must not turn if the parking brakes are locked.  The parking brakes must be reset after being replaced or if the position of the rear wheels has been changed. This must only be performed by the authorised specialist retailer.	x	
Drum brake (optional) Check for correct function	<ul style="list-style-type: none"> The braking effect must be present when the brake lever is actuated. The wheels must be firmly blocked when the drum brake is locked. The Bowden cable must not be damaged.  The drum brakes must be reset after being replaced or if the position of the rear wheels has been changed. This must only be performed by the authorised specialist retailer.	x	
Seat and backrest upholstery Check for contamination/damage	<ul style="list-style-type: none"> If contamination is found, clean the upholstery in line with the cleaning information. If the upholstery is damaged, have it replaced. 	x	
Moving parts Check for correct function and wear	<ul style="list-style-type: none"> Check that all moving parts (leg rests, foot plates, side panels, height-adjustable push handle) function smoothly and with little noise. 	x	
Screw joints Check that they are firmly seated	<ul style="list-style-type: none"> All screw joints must be firmly tightened. If the castor screw is loose, contact a specialist dealer immediately. (see fig. 46)  Self-locking nuts and screws lose their efficacy through being repeatedly released and tightened. Therefore, they must be replaced by an authorised specialist dealer.	x	
Wheels Check for correct function and damage	<ul style="list-style-type: none"> The wheels must run straight and not wobble. The wheels must move easily and with little noise when travelling. The wheels must be replaced if damaged. 	x	
Tyres (PU) Check for correct function and damage	<ul style="list-style-type: none"> Damaged or worn tyres must be replaced. 	x	

What	Description	Monthly	
		Daily / before using	
Pneumatic tyres (optional) Check for correct function and damage	<ul style="list-style-type: none"> • Check the tyre pressure • Pump the tyres up to the required pressure (see information printed on the side of the tyre). • Damaged or worn tyres must be replaced.  In case of air loss, the wheelchair can no longer be used as safe driving is not ensured.	x	
Push handle Check for correct function and wear	<ul style="list-style-type: none"> • The handles must be firmly attached. • The push handles must be at the same height and not show any obvious damage/distortion. • It must be possible to lock the fixing screw firmly (for optional height-adjustable push handles). 		x
Side panel, complete Check for correct function and damage	<ul style="list-style-type: none"> • It must be possible to remove, attach and lock the side panels without fault. • Defects and surface defects must be remedied. 		x
Leg rest/foot rest Check for correct function and damage	<ul style="list-style-type: none"> • It must be possible to remove, attach and lock the leg rests without fault. • Defects and surface defects must be remedied. 		x
Push rims Check for damage and wear	<ul style="list-style-type: none"> • The push rims must be firmly screwed to the wheels.  Danger of injury! Surface damage to the push rims must be remedied immediately.		x
Folding mechanism Check for smooth movement	<ul style="list-style-type: none"> • The wheelchair must fold up soundlessly. 		x
Wheels Check the wheels for correct function, damage and correct seating	<ul style="list-style-type: none"> • The spokes must not be loose, warped or broken. • Remove dirt and deposits from the quick-release axles and wheel hubs. • The wheel must not come free if the rear wheel is pulled to the side. 		x
Visual inspection , check for loose parts, breaks, corrosion or other damage	 If damage of this type is found, the wheelchair must no longer be used as safe driving is not ensured.		x
Cleaning Check for contamination	<ul style="list-style-type: none"> • The entire wheelchair must be cleaned as necessary depending on the level of contamination but at least once per month (see chapter Cleaning instructions). 		x

TROUBLESHOOTING

What	Possible causes	Measures
The rear wheels do not run straight	<ul style="list-style-type: none"> The spokes are loose, warped or broken. 	Visit an authorised specialist dealer
The wheelchair does not move in a straight line	<ul style="list-style-type: none"> The wheels have different tyre pressures (only if optional pneumatic tyres have been selected). 	Correct the tyre pressure
	<ul style="list-style-type: none"> The wheel axles are dirty. 	Remove the dirt
	<ul style="list-style-type: none"> The wheels are adjusted differently. The wheels are worn or damaged. The bearings of the front wheel fork cannot turn freely. The wheel bearings of the front wheels are dirty or damaged. 	Visit an authorised specialist dealer
The wheelchair is difficult to push	<ul style="list-style-type: none"> The wheel axles are dirty. 	Remove the dirt.
	<ul style="list-style-type: none"> The tyre pressure of the wheels is too low (only if optional pneumatic tyres have been selected). 	Correct the tyre pressure
	<ul style="list-style-type: none"> The brakes are set incorrectly. 	Visit an authorised specialist dealer
The front wheels are stiff or jam	<ul style="list-style-type: none"> The bearings are dirty or defective. 	Visit an authorised specialist dealer
Brake function is insufficient and uneven	<ul style="list-style-type: none"> The tyre pressure of the wheels is too low (only if optional pneumatic tyres have been selected). 	Correct the tyre pressure
	<ul style="list-style-type: none"> The brakes are set incorrectly. 	Visit an authorised specialist dealer
Squeaking and grinding noises	<ul style="list-style-type: none"> Various causes 	Visit an authorised specialist dealer

CLEANING

The wheelchair's frame parts can be wiped down with a damp cloth. A mild cleaning agent can be used in the case of more severe soiling.

The wheels can be cleaned using a damp brush with soft plastic bristles (do not use a wire brush!).

The upholstery materials can be washed by hand using mild soapy water at 40°C.

DISINFECTION

When manually reconditioning a used aid for reuse, all of the aid's components must be thoroughly treated/wiped with a disinfectant. Take particular care to disinfect surfaces that come into frequent contact with hands/skin, such as handles and armrests.

Please only use the following disinfectants; use of other chemicals might damage the wheelchair.

- ▼ Aldehyde-free disinfectants based on alcohol (max. 70% propyl alcohol)

DISPOSAL

If you no longer need the wheelchair, please contact your specialist dealer. They will then pick up the wheelchair and either dispose of it properly or make further use of it. If this is not possible, please take the wheelchair to your local recycling facility.



WARNING

Material damage: Do not use high-pressure cleaners, strong, corrosive chemicals or scouring agents for cleaning purposes.

Risk of corrosion: After cleaning, ensure that all materials are completely dried in order to preserve their quality.



WARNING

Safe disinfection cannot be guaranteed on upholstery parts featuring seams and textiles. In this case we recommend to replace these parts.

Material damage: Observe the use and processing instructions issued by the cleaning agent/disinfectant manufacturer.

Risk of infection: The product must be disinfected before each change of user.

FORWARDING / REUSING

Your product is suitable for loan / re-use, unless it is a custom-made product and marked accordingly.

The number of times it can be reused depends on the material wear conditions and the functional capabilities of the respective product. If the wheelchair is passed on to a new user or specialist dealer for reuse, please remember to hand over all technical documents that are necessary for safe usage.

The wheelchair must be cleaned and disinfected, and must be checked for damage and approved by the specialist retailer.

To do so, please check all the inspection points listed in the maintenance schedule on the wheelchair.

STORAGE

To store the wheelchair, ensure that the wheelchair is stored in a dry place protected against direct, strong sunlight and at a temperature of 0°C to +45°C. Do not activate the parking brakes. Secure the wheelchair against rolling away unintentionally.

After longer periods of storage (> 4 months), please check all the inspection points on the wheelchair listed in the maintenance schedule before reusing/redeploying the chair.



WARNING

Risk of infection: The product must be disinfected before each change of user. This is important to avoid cross-contamination. _____



NOTE

If the product is marked as a custom-made product, it cannot be passed on or reused. _____



WARNING

Do not store the wheelchair near a heat source or store objects on the wheelchair. _____

PRODUCT LABELLING

Stickers must remain legible and not be removed. Immediately replace illegible or missing stickers. The serial number sticker is very important for identifying the product, it is placed on the product label, which is placed below the seat on the cross strut. It must not be removed.

Further markings on the product:

SONDERANFERTIGUNG
CUSTOM-MADE DEVICE

For custom models, which were customer made for a particular user, the product label, intended purpose and warnings are different. Please pay attention to the additional documentation!



Wheelchair crash tested according to ISO 7176-19 and suitable for transporting persons in vehicles/ marking of the attachment points for the wheelchair restraint system on the wheelchair



Crash tested according to ISO 7176-19



Not approved as a seat for transporting passengers in a vehicle. Models marked with these labels have not been crash tested.

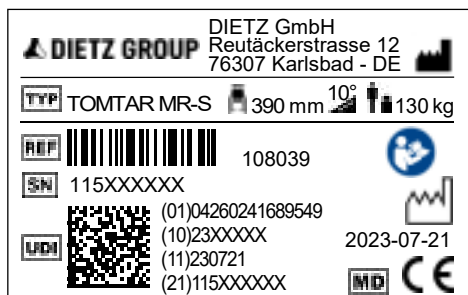

fig. 47

TOMTAR Trademark



Type/model



REF = Item number



SN = Serial number



UDI = Unique device identifier
(01) UDI-DI / GTIN
(10) Order number
(11) Date of manufacture (YYMMDD)
(21) Serial number



Seat width



Manufacturer/manufacturer's trademark/contact address



Maximum load capacity/load



Date of manufacture (YYYY-MM-DD)



Maximum safe gradient that can be driven on with the wheelchair*



Follow the user instructions



Medical device

* Depends on the wheelchair settings and user's abilities

WARRANTY

Warranty services refer to all product defects which are verifiably attributable to material or manufacturing flaws. The warranty period is 24 months as of receipt of notification of readiness for shipping, but following delivery at the latest. Damage which has occurred due to natural wear, intent, and negligent or improper operation or usage is excluded from the warranty obligation. This also applies to the use of unsuitable care products, lubricating oils or greases.

LIFETIME

The expected product service life is five years when used daily and if used as intended. This assumes compliance with the maintenance and safety specifications stipulated in this manual.

LIABILITY

The DIETZ GmbH is only liable if the product is used under the specified conditions and for the specified purpose. We recommend that the products be handled appropriately and cared for according to the instructions. DIETZ GmbH is not liable for damage caused by components and spare parts that have not been approved by DIETZ GmbH. Repairs must only be carried out by authorised specialist retailers or by the manufacturer itself.

TOMTAR®



Product group: Manual wheelchairs

Product: TOMTAR MR-S standard folding wheelchair

Product: TOMTAR MR-LG lightweight folding wheelchair

User manual version: 3.2 EN

As of 2023-11

DIETZ GmbH

Reutaeckerstrasse 12

76307 Karlsbad

Germany

Tel.: +49 7248.9186-0

Fax: +49 7248.9186-86

info@dietz-group.de

www.dietz-group.de

TOMTAR is a registered trademark belonging to DIETZ GmbH.
TOMTAR products are sold by DIETZ GmbH.

Misprint, falsities, price and product changes reserved.

© DIETZ GmbH, Karlsbad

Reproduction, either in part or in whole, only with written permission of
DIETZ GmbH, Karlsbad.