



OPERATING MANUAL

Eurochair 1.750 Lightweight wheelchair



Users with visual impairments can find the PDF-files together with further information on our website:

< *www.meyra.com* >.

➔ Contact your specialist dealer when required.

Alternatively users with visual impairments can have the documentation read out by a helper.

Contents

Overview	5
Meaning of the applied markers	6
Introduction	6
List of models	6
Indications / contraindications	6
Acceptance	7
Intended purpose	7
Use	7
Wheelchair folding/unfolding/carrying	8
Adjustment	8
Combination with manufacturer foreign products	9
Reinstallation	9
Life span	9
Brake	10
Pressure brake - user	10
Locking the brakes	10
Releasing the brakes	10
Service brake	10
Drum brake for accompanying persons	10
Function as operating brakes	10
Brake lever extension	10
Leg supports	11
Heel strap	11
Removing the heel strap	11
Attaching the heel strap	11
Length adjustment of the heel strap	11
Lower leg support	11
Footplates	11

Leg support upper part	11
Turning the leg supports to the side	11
Swivelling in the leg supports	11
Removing the leg supports	12
Attaching the leg supports	12
Mechanically height-adjustable leg supports	12
Lifting/lowering the leg support	12
Arm supports	12
Removing the arm support	12
Inserting the arm support	13
Swivelling up the arm support	13
Height adjustment of the arm support	13
Back support	13
Adjustable back	13
Removing the back support upholstery	13
Placing the back support upholstery	14
Back support with angle adjustment	14
Seat	14
Push handles	14
Push handles with tube guidance	14
Height adjustment of the push handles	14
Wheels	14
Drive wheels	14
Manoeuvre rollers	15
Support castors	15
Support castor length	15
Stick-in support castors	15
Removing/inserting the support castors	15

Handrim	15	Disposal	22
Propelling the wheelchair	15	Maintenance	22
Therapy table	16	Maintenance	22
Retaining strap	16	Technical data	24
Walking aid holder	16	Tyre pressure of pneumatic tyres	24
Removing/attaching the cup	16	Applied norms	24
Basic safety information	17	Data according to ISO for model 1.750 Eurochair	25
Accompanying person	17	Further technical data for model 1.750 Eurochair	25
Transfer out of the wheelchair	17	Meaning of the symbols on the washing instruction	26
Reaching for objects	18	Meaning of the labels on the wheelchair	27
Driving on falling, rising or transverse gradients	18	Meaning of the symbols on the type plate	27
Crossing obstacles	18	Warranty / Guarantee	28
Loading the wheelchair	19	Warrantee / Guarantee section	29
Transport in vehicles	19		
Transport safety of the empty wheelchair	19		
Transport of people inside a motor vehicle	19		
Transport in public methods of transportation	20		
Driving on public highways	20		
Cleaning	20		
Finish	21		
Disinfection	21		
Repairs	21		
Repairs	21		
Customer Service	21		
Spare parts	21		
Maintenance schedule	22		
Information for extended pauses of use	22		

OVERVIEW

The overview shows the most important components of the wheelchair.

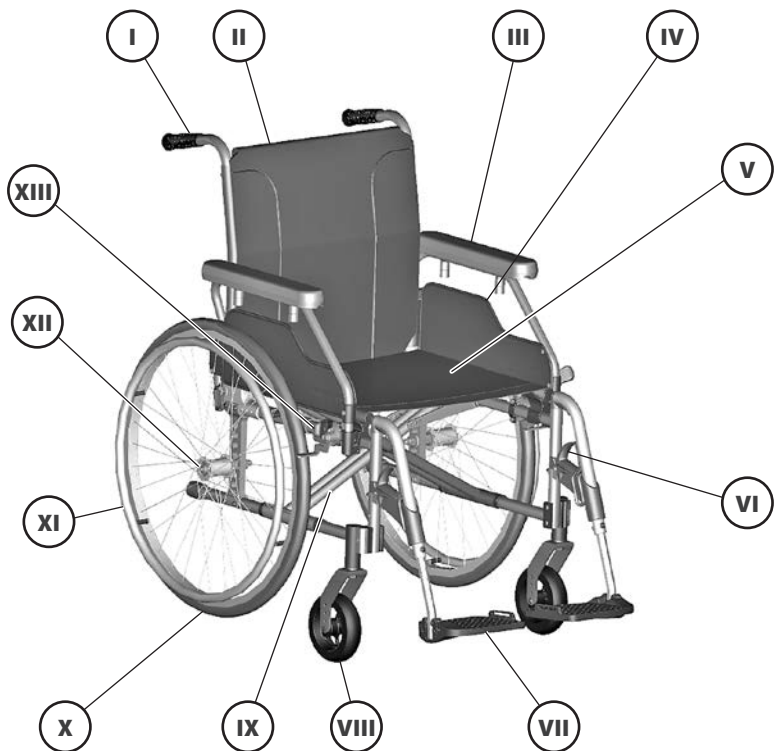

Pos. Description

(I)	Push handle	(VIII)	Steering wheel
(II)	Back support	(IX)	Type plate (on the double crossbrace)
(III)	Arm support	(X)	Driving wheel
(IV)	Arm support / clothes guard	(XI)	Handrim
(V)	Seat belt/seat cushion	(XII)	Locking knob – Quick release axle
(VI)	Locking lever – Leg support	(XIII)	Brake lever – pressure brake
(VII)	Footboard/footplates divided		

MEANING OF THE APPLIED MARKERS

Safety instructions with a coloured background are mandatory and need to be observed under any circumstance!

- ➔ This symbol indicates tips and recommendations.
- [] Reference to a picture number.
- () Reference to a function element within a picture.

INTRODUCTION

Read and observe this manual before first operation.

Your specialist dealer should also introduce you into the use of your wheelchair.

This operating manual is to help you get accustomed to the handling of the wheelchair as well as to prevent accidents.

- ➔ Please note that the illustrated equipment variants can deviate from your model.

We have therefore also listed chapters with options that might not be applicable for your individual wheelchair. A list of the available options and accessories can be viewed in the order form of your wheelchair.

Inform yourself regularly about the product safety, possible recalls and general handling instructions of our products in the < *Information center* > on our website:

< www.meyra.com >.

We have developed a product that fulfils the technical and legal requirements of medical devices. For information about a severe accident that can still not be ruled out completely, please use our E-mail address < info@meyra.de > and inform the responsible governmental agency of your country.

LIST OF MODELS

This operating manual applies to the following model:

Model 1.750

INDICATIONS / CONTRAINDICATIONS

In case of allergic reactions, skin rashes and/or pressure sores during the use of the wheelchair sores contact a doctor immediately.

In order to prevent contact allergies, we recommend to use the wheelchair only when wearing clothes.

Upon others, the wheelchairs serves as support in cases of extremely pronounced walking handicaps, resp. disability to walk, e.g. through:

- paralysis,
- defects or deformations of limbs,
- loss of limbs,
- damages or contractures in joints,
- other diseases (severe to fully pronounced impairments in mobility/walking in cases of structural an/or functional damages of the lower extremities, u. o. amputations, results of injuries, musculoskeletal/neuromusculoskeletal caused movement disorders etc.).

During the individual provision with the prescribed wheelchair, also observe the physical and psychological condition, age of the handicapped person as well as the personal situation at home and in the private environment.

This applies to the person using the wheelchair as well as to the active accompanying person.

Every provision should be checked, tested and aligned to the individual ability limitation caused by the defined disease pattern through a specifically trained person (medical device consultant, rehabilitation advisor, u.o.). This also includes that people with problems listed in the counter indications, in each individual case, can certify the physical ability to operate the wheelchair.

The wheelchair may not be used in case of an inability to sit.

The wheelchair may not be used without an accompanying person, in cases of:
uncontrolled balance disorders,
cognition disorders,
loss of extremities on both arms,
contractures / damages of the joints on both arms,
insufficient or no eyesight.

- ➔ Please ask your doctor, therapist or specialist dealer to these and possible other risks in combination with this product.

ACCEPTANCE

All products are checked for faults in the factory and packed in special boxes.

- ➔ However, we request that you check the wheelchair for possible transport damage immediately on receipt – preferably in the presence of the carrier.
- ➔ The packaging of the wheelchair should be stored for a further transport that might become necessary.

INTENDED PURPOSE

The wheelchair serves for independent movement of one person or transport through an accompanying person.

The wheelchair was developed for adults.

USE

In case of physical limitation, such as blindness, a driving ability certifications for independent driving of the wheelchair is required.

Do not reach into the spokes or grip the tyres of the rotating wheels. – Danger of injury!

Do not reach into the space between the pressure brake and the tyre when propelling the wheelchair. – Danger of injury!

Avoid a jerky propulsion of your wheelchair. – Danger of tipping over or tilting!

Do not use the wheelchair without attached leg supports and arm support units!

In certain configurations your wheelchair might exceed the maximum dimensions of emergency routes. Always make sure whether possible escape routes are wide enough for your wheelchair.

If you only have limited or no mobility, ensure that you can get help at any time in case of a break down.

The wheelchair is applicable on level, firm surfaces and can be used as follows:

- for indoors (e.g. apartment, day care),
- outdoors (e.g. paved paths in parks),
- as a companion on tours (e.g. in a bus or train),
 - ➔ In specific dimensions (overall height, overall width, overall length, turning radius) your wheelchair is not suited for transport within a train.
 - ➔ Get information on possible limitations before the transport.
- transport within an airplane should only be done with PU-tyres.
 - ➔ Ask the airline for possible limitations before transport in an airplane.

- Never expose the wheelchair to extreme temperatures and damaging environmental conditions, such as sunlight, extreme cold or salty water.
- Sand and other dirt particles can seize on moving parts and render them without function.
- Use only the handrims on the drive wheels to propel your wheelchair.

You must not let yourself be carried in your wheelchair by having the wheelchair lifted from the floor. Parts that are not securely fixed, e.g. side elements or leg supports, can come away and thus cause an accident.

➔ The wheelchair is a vehicle and not a carrying device.

Only apply the wheelchair within the scope of the specifications and limitation described in chapter *Technical data* on page 24.

WHEELCHAIR FOLDING/UNFOLDING/CARRYING

Your wheelchair can be folded without the aid of tools.

1. Remove the seat cushion, if applicable.
2. Lift up the footplates or remove the leg supports.
3. Pull the seat belt upward in the centre of the front and back.
4. If necessary remove the connection rod of the double handrim drive or the push bar.

Your wheelchair can be carried without difficulty when folded.

For this, push one lower arm from the front under the upward folded seat belt. Place other hand underneath the rear seat fold for support.

Lift the wheelchair to horizontal position.

Tip the wheelchair slightly to one side in order to make the unfolding easier. At the side resting on the floor, press the seat tube down to the end stop.

- ➔ You may need to press down both seat tubes with the hands in order to do this.
- ➔ Ensure that the seat tube sits securely on the support surface.

ADJUSTMENT

Always have adaptation, adjustment or repair work carried out by a specialist dealer.

The wheelchair offers manifold adjustment possibilities to individual vital statistics. Before first use an adaptation of the wheelchair and a practical instruction in the functionalities of your wheelchair should be carried out by your specialist dealer. The adaptation will take into account the driving experience, the physical limits of the user and the main place of use of the wheelchair. Before first use, check the functionality of your wheelchair.

- ➔ We recommend a regular control if the wheelchair adjustment in order to ensure a long-term optimal provision even with changing illness/handicap patterns of the user. An adaptation every 6 month is recommendable.

COMBINATION WITH MANUFACTURER FOREIGN PRODUCTS

Any combination of your wheelchair with components not supplied by us generally results in an amendment to your wheelchair. Please inquire with us if there is a valid combination clearance/release.

Auxiliary drives

Mounting of additional- and front attachment drives constitute an extreme amendment of the wheelchair. The amendment will result in a forfeiture of the declaration of conformity for the wheelchair.

- The verification of conformity in combination with the valid medical device directive / medical device ordinance lies in the responsibility of the supplier of the additional or header drive. He is also responsible for the product included documentation of the medical product combination.

REINSTALLMENT

The wheelchair is suited for reinstallation. With the building block system the wheelchair can be fit to accommodate different handicaps body sizes. Before reimplementation the wheelchair is to undergo a complete inspection.

- Hygienical measures required for reinstallation are to be carried out according to a validated hygienic plan and must include disinfection.

The service manual, intended for the specialist dealer provides information to the reinstallation and reinstallation frequency of your wheelchair.

LIFE SPAN

We expect an average life span of about 4 years for this wheelchair, as far as the wheelchair is applied for its designated purpose and all maintenance and service guidelines. The life span of your wheelchair depends upon the frequency of use, the application environment and care. The implementation of spare parts can prolong the life span of the wheelchair. As a rule spare parts are available up to 5 years after production is discontinued.

- The indicated lifespan does not constitute additional guarantee.

BRAKE

Arrange an immediate repair of the brakes by your specialist workshop if the braking performance reduces.

Wheelchairs with PU-tyres when stored for longer periods of time, should be put away safely without activated pressure brakes, since otherwise permanent deformations to the tyre surface could occur.

By locking the brakes with the brake lever (1 on page 30<?>) the wheelchair is secured against rolling away unintentionally (parking brake).

Depending on the version, the wheelchair can be equipped with pressure brakes [2 on page 30<?>] or with drum brakes [3 on page 30<?>].

Pressure brake - user

Locking the brakes

To secure the wheelchair against any unintentional rolling, press both brake levers forward all the way [4 on page 30<?>].

➔ It should not be possible to push the wheelchair forward when both brakes are locked.

Releasing the brakes

Pull both brake levers back all the way [2 on page 30<?>].

Service brake

The wheelchair is braked down with help of the handrims.

➔ If needed use suitable gloves in order to brake down the wheelchair.

Drum brake for accompanying persons

The drum brake [3 on page 30<?>] is activated by the accompanying person through the brake levers (5 on page 30<?>).

Function as operating brakes

Use both brake levers evenly and only lightly in order to achieve a controlled deceleration of the wheelchair.

Locking the drum brakes

Pull both brake levers (5 on page 30<?>) and press the locking latch (6 on page 30<?>) forward.

Release the brake lever. – Depending on the adjustment the latch engages in the first (A on page 30<?>) or second (B on page 30<?>) locking position and activates the brake.

➔ If the third locking position (C on page 30<?>) is required to activate the brake, it must be readjusted by a specialist workshop.

Loosen the drum brakes

Pull both brake levers (5 on page 30<?>) until the latches (6 on page 30<?>) automatically jump out of the locking points.

Let go of both brake levers. – The parking brakes are released and the wheelchair ready for use.

Brake lever extension

Do not use the grips of the brake lever as support.

Do not pull off the brake lever extension whilst in motion. – Accidents could result if the brake lever extension is drawn too much.

The brake lever extensions (7 on page 30<?>) multiply the applied brake force and reduce the force you need to apply in order to lock the brakes.

➔ For transfer into/out of the wheelchair pull the brake lever extension off of the brake levers.

➔ Only use the wheelchair with the brake lever extensions attached.

LEG SUPPORTS

Before any actions on the leg supports the wheelchair is to be secured against unintentional rolling motions.

- ➔ Therefore observe chapter *Brake* on page 10.

Heel strap

Do not drive without the heel strap.
– Danger of accidents!

The heel strap (8 on page 30<?>) prevents the feet from sliding off the back of the footplates.

Removing the heel strap

For removal the heel strap is pulled off of the attachment bar (9 on page 30<?>) or, after opening the velcro fastener, pulled from the insert tube (10 on page 30).

Attaching the heel strap

For attachment the loop of the heel strap is slid over the attachment bar (9 on page 30<?>) or the heel strap is guided around the insert tube (10 on page 30) and closed with the velcro fastener.

Length adjustment of the heel strap

For length adjustment the heel strap is adjusted in length with help of the velcro fastener.

Lower leg support

The footplates are to be folded up for entering or exiting the wheelchair [11 on page 31].

- ➔ Check the locking points!
 - Remove both feet from the footplates.
- ➔ The footplates are to be lowered again before starting to drive [12 on page 31].

Footplates

The footplates can be folded outward [11 on page 31] and up resp. inward and down [12 on page 31].

Leg support upper part

The upper leg support with an inserted lower leg support is termed leg support.

Turning the leg supports to the side

Leg supports turned to the side are released automatically and can easily come off. Note this when handling (e.g. transport).

For easy transfer out of/into the wheelchair as well as driving closer to a closet, bed or bathtub the leg supports can be swivelled away toward the in-/outside [13 on page 31].

Fold up the footplates in order to swivel the leg supports to the sides.

- ➔ Therefore observe chapter *Lower leg support* on page 11.

Afterwards pull or press the respective locking lever (14 on page 31) resp. (15 on page 31) backward and swivel the corresponding leg support outward.

Swivelling in the leg supports

For inward swivelling, let the leg supports swivel forward until the lock audibly engages [11 on page 31].

- ➔ After audibly swivelling the leg supports inward check the respective locking device.
- ➔ Afterwards observe chapter *Lower leg support* on page 11.

Removing the leg supports

With removed leg supports there is an increased danger of tilting backwards.

For easy transfer into and out of the wheelchair as well as a reduced wheelchair length (important for transport) the leg supports can be removed [16 on page 31].

For removal first swivel the leg support sideways [13 on page 31] and then remove them toward the top [17 on page 31].

- ➔ Therefore observe chapter *Turning the leg supports to the side* on page 11.
- ➔ Watch for possible danger of jamming!

Attaching the leg supports

For inserting press the leg supports, swivelled to the side, parallel to the front frame tube and lower it into place. – In doing so the holding pin must slide into the frame tube.

- ➔ After attachment swivel the leg supports inward [12 on page 31].
- ➔ Therefore observe chapter *Swivelling in the leg supports* on page 11.

Mechanically height-adjustable leg supports

Never put the free hand into the adjustment mechanism. Have the leg support secured by an accompanying person against unintentionally falling down.

Do not let the leg support drop on its own weight. – Danger of injury!

Lifting/lowering the leg support

Before lifting/lowering relieve the leg support by an accompanying person by slightly lifting it up.

Afterwards loosen the clamping lever (18 on page 31) and have the leg support lifted/lowered slowly to the desired level by an accompanying person.

After the adjustment retighten the clamping lever (18 on page 31).

ARM SUPPORTS

Do not use the arm supports to lift or carry the wheelchair.

Do not drive without the arm supports.

No not grab between the frame and arm support. – Danger of squashing!

When the wheelchair is being pushed by an attendant the user is to place his hands onto the arm cushions or in his lap and not at the sides between body and arm support. – Danger of squashing the fingers!

During lateral transfer without arm support, there is a danger of unintentionally releasing the brake and soiling the clothes on the drive wheel.

The arm supports version 1 [19 on page 32] and version 2 [20 on page 32] is (depending on version) removable, height adjustable and at the same time serve as padded arm support, clothes guard and wind guard.

Removing the arm support

To remove the arm support, first fold the locking lever (21 on page 32) upward and swivel the arm support towards the top [22 on page 32].

Afterwards fold the arm support by about 90° inward [23 on page 32] and then remove it toward the top [24 on page 32].

Inserting the arm support

Fir fold the up-folded arm support inward, behind the back support [23 on page 32] and then insert it from the top into the guide [25 on page 32].

Afterwards turn the arm support about 90° outward, the lower it to the front into the guide [26 on page 32] and fold the locking lever (21 on page 32) down.

- ➔ The rear tube of the arm support must lie in the guide groove on the back support (27 on page 32).

Swivelling up the arm support

For transfer out of/into the wheelchair the arm support can be swivelled upward as well as folded behind the back support [23 on page 32].

To swivel the arm support up, first fold the locking lever (21 on page 32) upward and swivel the arm support towards the top [22 on page 32].

Afterwards fold the arm support about 90° inward behind the back support [23 on page 32].

- ➔ On the version with drum brake, the arm support cannot be folded behind the back support.

Height adjustment of the arm support

For height adjustment of the arm support secure the support pad with one hand to prevent it from falling down.

Danger of jamming during the height adjustment of the arm supports between the wheels and adjustment lever.

The upholstered arm support pads, depending on model, can be adjusted in height in 5 steps [28 on page 33].

Press down on the pressure button (29 on page 33) to lift or lower the padded arm support and at the same time slide the padded arm support into the desired height. Afterwards slide the padded arm support again until it audibly locks into place.

- ➔ Check the locking device by trying to pull or push the padded arm support.

BACK SUPPORT

Adjustable back

In case of too tight spanning straps, the wheelchair can no longer be unfolded completely!

- ➔ Loosen the spanning straps until the wheelchair can be unfolded completely again!

The back strap is tightened through the back tubes [30 on page 33].

The back support lag is adjustable through a velcro strap on the spanning straps (48 on page 34).

The back support upholstery (47 on page 34) is placed over it and attached with the velcro strap.

Removing the back support upholstery

For removal, first pull off the rear part of the back support upholstery (47 on page 34), then fold it over to the front [] and pull it off of the adjustable back strap (48 on page 34).

Placing the back support upholstery

The adjustable back support strap has influence on the stability of the torso.

For attachment, place the back support upholstery (47 on page 34) centered around the upper spanning strap (48 on page 34) and attach to the adjustable back support strap with the velcro fastener.

- ➔ For a soft upper edge you should leave a little space between the upper spanning belt (48 on page 34) and the folded back support upholstery (47 on page 34).
- ➔ When the user leans against the front cushion again, pay attention that:
- ➔ The pressure of the back must be spread evenly throughout the back cover.
- ➔ A complete hand should fit in between the cover and back at the upper edge of the back cover.

Back support with angle adjustment

An angle adjustment increases the danger of tilting and may only be carried out with support castors attached.

SEAT

The seat belt is tightened by unfolding the wheelchair.

PUSH HANDLES

Push handles with tube guidance

The push handles [31 on page 33] are guided swivel-proof inside the back tube and steplessly height by up to 10 cm.

Height adjustment of the push handles

With the clamping lever swivelled down, the respective push handle may not let itself be moved.

The maximum height adjustment of the push handle height has been reached when a marking is visible on their tube.

First hold onto the push handle that is to be adjusted then swivel the corresponding clamping lever (32 on page 33) with the other hand into the horizontal position.

Then adjust the push handle to the desired height and clamp it tight [33 on page 33].

- For this press the clamping lever downward (32 on page 33).

- ➔ After each adjustment the secure fit of the push handles is to be checked with a pull-/push test!

WHEELS

Tyres are made of a rubber mixture and can leave permanent or difficult-to-remove marks on some surfaces (e.g. plastic, wooden or parquet flooring, carpets, mats).

Drive wheels

Do not use the wheelchair without mounted drive wheels.

After inserting the drive wheel the locking button (34 on page 33) must stick a couple of millimetres out of the wheel nut.

The drive wheels are supported on a quick release axle [35 on page 33] and can be removed resp. attached without tools.

First press the locking button (34 on page 33) of the quick release axle in the center of the hub.

Afterwards remove or attach the drive wheel.

- ➔ If the drive wheels has too much side-ward lag or the quick release axle does not engage, contact your specialist dealer immediately for repair.
- ➔ No person may be seated in the wheelchair during assembly or removal. The wheelchair should stand on a level and firm surface. Before starting the disassembly work, support the frame to prevent the wheelchair from tipping over and secure it to prevent an unwanted movement or tipping over.

MANOEUVRE ROLLERS

With active shunting castors the wheelchair cannot be braked resp. secured through the brake levers.

The shunting castors [36 on page 33] enable shunting in tight spaces.

- ➔ When the drive wheels are attached the shunting castors have no function.
- ➔ When parking the wheelchair the brakes of the shunting castors (37 on page 33) are to be engaged.

SUPPORT CASTORS

Support castors do not provide sufficient protection against tipping over in certain situations.

Especially in combination with short wheel base and with a seat angle of more than 4°.

Definitely refrain from the following:

- Leaning the upper body far back.
- Jerky acceleration, especially when driving uphill.

In order to raise the tilting stability never drive without the support castor swivelled to the back.

A slanted tube with integrated pedal cap [38 on page 33] on both sides serves for more tilting stability.

Support castor length

In order to adjust the length of the support castors, press down the spring button (39 on page 33) and telescopically pull or push the support castor to the desired length.

Stick-in support castors

The insertable support castors can be inserted from the back into the lower frame tubes [38 on page 33].

Removing/inserting the support castors

Depress the spring button (40 on page 33) in order to remove/insert a support castor.

HANDRIM

Weather related danger of slipping of the hands on the damp, smooth handrims.

- ➔ If needed apply optional handrim cover.

Through the handrims (41 on page 33) of the drive wheels the wheelchair can be propelled with both hands.

Propelling the wheelchair

Both handrims are to be operated simultaneously to drive straight forward.

A curve can be driven by operating only one handrim.

THERAPY TABLE

Danger of jamming when sliding on the therapy table!

Sharp objects (e.g. watches, rings, knives or belt buckles) as well as coarse dust can cause unattractive brush marks in the surface of the therapy table.

Do not place any hot objects onto the therapy table.

Only use the therapy table in a completely inserted condition.

Do not drive with the therapy table attached when there are loose objects or containers with fluids on it.

For support, do not press onto the front edge of the therapy table.

Do not use aggressive or granular cleaning agents to clean the therapy table.

Do not use the therapy table as handle for carrying or shunting the wheelchair.

The therapy table is pushed from the front over the arm support cushions [42 on page 34].

➔ Ensure that the therapy plate sits securely on the arm supports pads.

RETAINING STRAP

Make sure that no objects are trapped between belt and the body!

The retaining strap is not part of the retaining system for the wheelchair and/or the driver during transport in motor vehicles.

The retaining strap [43 on page 34] is attached to the respective back support tube.

The retaining strap serves to stabilise the sitting position and prevents tilting forward out of the wheelchair, especially during abrupt stopping of the wheelchair.

To fasten the retaining strap, pull both ends forward and audibly let the buckle click into place.

To open the retaining strap [43 on page 34], press down the release button (45 on page 34) and pull the two ends of the strap apart.

➔ The retaining straps [43 on page 34] can be adjusted in length and should not be pulled too tight.

WALKING AID HOLDER

Have a defective retaining strap or defective cup replaced as soon as possible by an authorised specialist workshop. – Danger of accidents!

The walking aid holder, is only intended for accommodating crutches or walking sticks.

Depending on the vehicle the walking aid is placed into the cup [50 on page 34] and fastened with the strap [49 on page 34].

If needed the walking aid can be placed from the top through the closed retaining strap [49 on page 34] into the cup [50 on page 34].

Removing/attaching the cup

To remove the cup (51 on page 34), pull it upward off of the cup bracket.

For attaching the cup, slide the middle or one of the outer holders from the top as far as possible onto the cup bracket [50 on page 34].

BASIC SAFETY INFORMATION

This safety information is an extract of the *Safety and general handling instructions*, that can be found on our website: < www.meyra.com >.

The wheelchair serves solely for transporting one sitting person.

→ Other pulling or transporting uses do not comply with its intended purpose.

Do not insert fingers into open frame tubes (for example after removing the arm supports, leg supports or support castors).
– Danger of injury!

Danger of jamming in movable parts of the cross brace.

Scuttling (rolling motion of the wheelchair with help of the feet) is only permitted with creeping rolling speed on horizontal, level surfaces indoors.

When scutteling watch for the possibility of jamming the feet.

In doing so the sitting position may not be slid onto the front third of the seat.

A stable sitting position is to kept while using the wheelchair, even when not in motion and especially on hills and slopes.
– Danger of accidents!

In a safe sitting position the back of the user lies directly on the back support upholstery and the hip of the user is at the back end of the seat.

Danger of injury, e. e. skin abrasions when inadvertently activating the brake levers.

Transit out of the wheelchair on hills/slopes may only be carried out in emergencies and with the aid of an accompanying person and/or helper! – Danger of accidents!

Adjust the seat inclination only when the wheelchair is standing on a horizontal, level surface. A danger of tipping over exists on gradients!

Increased danger of tipping over when using the angle adjustable back support.

Before starting to drive make sure that no negative seat inclination has been adjusted, respectively that a safe seating position is ensured.

You should not smoke while using the wheelchair.

Exposure to direct sunlight can cause seat covers/upholstery, arm support pads, leg supports and handles to heat up to over 41 °C. – Contact with exposed skin can result in injury! Prevent such heating by parking the wheelchair in a shaded area.

Special attachment points for fastening objects that are to be carried along are not provided.

Accompanying person

The accompanying person must be made aware of all possible danger situation before the start of his/her supportive involvement. The parts of your wheelchair that are held onto by the accompanying person are to be checked for tight fit.

Transfer out of the wheelchair

Drive with the wheelchair as closely as possible to the spot where you want to switch out of the wheelchair.

→ Herefore additionally observe chapters *Brake* on page 10 and *Swivelling up the arm support* on page 13.

→ We recommend to conduct the transfer from the wheelchair together with an aid.

Reaching for objects

Avoid an extreme forward or backward inclination of the upper body when picking up or placing heavy objects. – Danger of wheelchair tipping over, especially in the case of narrow seat widths and high seat heights (seat cushion)!

Driving on falling, rising or transverse gradients

For safety reasons, the maximum permitted gradient is limited because the tip-over stability and the braking and steering behaviour are impaired by a reduced floor/road.

➔ Observe chapter *Technical data* on page 24.

For your own safety, we recommend that you use the assistance of an accompanying person for driving slopes of more than 1% tilt.

➔ This low gradient value is valid for persons that are not able to effect even the smallest centre of gravity change by changing the position of their upper body.

The accompanying person should be aware that the control of the wheelchair requires more strength on a downward slope/ hills than on a level driving surface and that there is an increased danger of slipping.

Never lean towards the downhill direction when driving on rising, falling or transverse gradients.

Avoid jerky changes of the driving condition (especially with critically adjusted driving parameters as for example an active wheel position).

Never drive faster than walking speed.

There is an increased danger of tilting while driving backwards.

While driving in curves and when turning on inclinations and slopes there is a danger of tilting.

The braking force transferred to the driving surface is much less on a downward slope than on a level driving surface and is further reduced by poor road conditions (e.g. rain, snow, grit, dirt). A dangerous slipping of the wheels due to excessive braking and an associated unwanted course deviation must be avoided by way of a careful dosed braking.

At the end of the downward slope, take care that the foot plates do not make contact with the ground and endanger you through a sudden braking effect.

Transverse surfaces to the driving direction (e.g. transversely sloped pavements) effect a turning of your wheelchair in the downhill direction. You or an accompanying person must compensate for this drift by a countersteering.

Crossing obstacles

When driving over an obstacle the support castors are to be swivelled away or removed. – The support castors could make contact with the ground when driving over an obstacle and render the wheelchair without manoeuvrability.

After having overcome stairs, support castors that were previously removed need to be mounted again resp. support castors that were swivelled to the side, swivelled back into place.

Each crossing of obstacles involves a risk! Even flat obstacles (e.g. sills, carpet edges, small steps or similar) represent a danger of tipping.

The crossing of obstacles is a special danger situation in which a combination of the safety advice in the sections headed uphill driving, downhill driving and driving transverse to a slope must be observed in addition to other safety advice.

For your own safety all obstacles should only be driven over with an accompanying per-

son. The pedal tube is to be used as support for each manual tilting of the wheelchair.

The unassisted, safe, crossing of small obstacles (< 4 cm) is only possible with a sufficiently safe control of the wheelchair.

Always approach small obstacles, e.g. steps or curbs, slowly and at a right angle (90°) until the steering wheels almost touch the obstacle. Briefly stop the wheelchair and then drive over the obstacle.

Always drive over an obstacle forwards (not backwards) and simultaneously with both front/rear wheels in order to prevent a sideways tipping of the wheelchair.

Always maintain a safety distance between the wheelchair and drops, stairs and similar obstacles sufficient for reaction, braking and turning.

If possible, let one or more helpers lift you out of the wheelchair and carry you to the destination point.

The crossing of stairs is only possible with the assistance of two helpers who are familiar with the danger situation and firmly guide the wheelchair.

➔ The helpers may only hold (without lifting) the wheelchair with the push handles and the side frame.

Existing support castors are to be removed, since they might pose a danger to the aid under certain circumstances.

Loading the wheelchair

Do not use the leg supports, arm supports or accessory parts in order to lift the wheelchair!

Before lifting, the wheelchair is to be secured against unintentional rolling motions!

➔ Therefore observe chapter *Turning the leg supports to the side* on page 11.

The parts detached for loading must be carefully stowed and carefully attached again before the next journey.

The weight of the wheelchair is reduced when you remove detachable components.

The wheelchair can be also loaded with the aid of ramps or lifting platforms.

➔ Therefore observe the respective user manual and the load capacity of the ramp resp. lifting platform.

Transport in vehicles

The parts detached for the transport must be carefully stowed and carefully attached again before the next journey.

No special carrying points are allocated for carrying detachable components.

The following procedures may be necessary due to lack of space for the transport in vehicles:

- Remove the leg supports.
- Remove the arm supports.
- Remove or fold over the back support.
- Detach the drive wheels.

Transport safety of the empty wheelchair

All regulations and directions of the respective transport company are to be observed. – Ask for these before the transport.

The wheelchair is to be stored and secured in such a fashion that it does not present any danger to you or others.

Transport of people inside a motor vehicle

To determine if your wheelchair is approved as a seat for person transport inside a motor vehicle, please look at the type plate of your wheelchair.

➔ Therefore view chapter *Meaning of the symbols on the type plate* on page 27.

- ➔ Wheelchairs that are not suited for use as a seat for transport in a motor vehicle are marked with an additional label. – For this observe chapter *Meaning of the labels on the wheelchair* on page 27.
- ➔ Observe the guideline < *Safety with Meyra-wheelchairs, also during transport in motor vehicles* >! – This document and further information are available in the < *Information center* > on our website < www.meyra.com >.
- ➔ Anchoring systems released for transport of people are to be viewed in chapter *Applied norms* on page 24.

Transport in public methods of transportation

Your wheelchair is not designed for user transport in public transportation vehicles. Limitations may occur. We recommend use of one of the firmly built in seats of the public vehicle.

Should it nevertheless become necessary to carry out the transport while sitting in the wheelchair, the following needs to be observed:

- Use the space designated by the public transportation services for parking.
- Observe the regulations of the transport company before parking the wheelchair.
- Park your wheelchair opposite to the driving direction in the reserved space.
- The wheelchair is to be placed so that the back support it will be supported by the border of the parking space.
- One side of the wheelchair must also lie against the border of the parking space, so that the wheelchair cannot slide away in case of an accident or sudden braking manoeuvre.
- Additionally activate the parking brakes.

Driving on public highways

Observe the valid regulations for public traffic of your country and if necessary ask your

specialist dealer for required accessories.

Your wheelchair can optionally be fit with lighting equipment. The lighting equipment consists of:

- Reflectors on the back support
- Reflectors on the drive wheels.

With limited visibility and especially in the dark we recommend to mount active lighting equipment and to turn it on in order to see better and be seen.

- ➔ When participating in public traffic the user is responsible for the functional- and operationally safe condition of the wheelchair.
- ➔ The valid traffic regulations must be observed and abided when participating in public traffic.
- ➔ Wear light-coloured and conspicuous clothing when driving in darkness.
- ➔ When driving in the dark avoid using the road or bicycle lanes.
- ➔ Observe that the lighting equipment is not covered by clothes or any other objects attached to the wheelchair.
- ➔ In case of physical handicaps, such as blindness the use of the wheelchair is only permitted with an accompanying person.

Cleaning

The plastic panelling is attacked through non-ionic tensides as well as solvents and especially alcohol.

The cushions and covers are normally fit with care instructions (instruction for care).

- ➔ For this observe chapter *Meaning of the symbols on the washing instruction* on page 26.

In all other cases the following information is true:

- ➔ Clean the upholstery with warm water and hand washing liquid.

- ➔ Remove spots with a sponge or a soft brush.
- ➔ Wash off persistent dirt with commercial fine detergent.
- ➔ Do not soak! Do not machine wash!

Follow-up with clean water and allow to dry.

The chassis, the lighting equipment and wheels can be cleaned damp with a mild detergent. Afterwards dry off well.

- ➔ Check the chassis for corrosion damages as well as other damages.
- ➔ Only clean the plastic parts with warm water and neutral detergent or soft soap. Further information to cleaning can be found in the < *Information center* > on our website: < www.meyra.com >.

Finish

The high quality finish ensures an optimum of protection against corrosion.

- ➔ Should the coating be damaged with scratches or similar, these areas can be touched up with our paint pen available at the specialist dealer.

Slight lubrication of moving parts will ensure for their long functioning.

Disinfection

If the product is used by more than one person (for example in a care centre), the use of a commercial disinfectant is mandatory.

- ➔ Before disinfection the upholstery and handles are to be cleaned.
- ➔ A spray- or wiping disinfection is permitted with tested and accredited disinfectants.

You can get information on tested and permitted disinfectants and procedures at your national facility for health protection.

- ➔ During the use of disinfectants it can happen that surfaces might be affected in such a fashion that the long term functionality of parts can be limited.

- ➔ In doing so the manufacturers instructions are to be observed.

Repairs

Repairs are generally to be carried out by a specialist dealer.

Repairs

Trustingly contact your specialist dealer for maintenance work. He has been introduced to the maintenance.

Customer Service

In case you have any questions or need help please contact your specialist dealer who can assume counselling, customer service and repairs.

Spare parts

Spare parts can only be ordered from specialist dealers. In case of repair work, only original spare parts are to be used!

- ➔ Spare parts from other manufacturers can cause malfunctions.

The spare parts list with the respective part numbers and drawings is available at the specialist dealer.

In order to ensure the correct delivery of a spare part, always quote the corresponding serial number (SN) of the wheelchair! You will find this on the type plate.

Whenever a wheelchair change/modification is carried out by the specialist dealer, the supplementary information, e.g. assembly/operating instructions must be attached to the operating manual for the wheelchair, the date of the modification must be recorded and stated when ordering spare parts.

This should prevent wrong order details on future spare parts orders.

Information for extended pauses of use

No special measures are required during extended pauses of use. Nevertheless storage temperatures are to be observed.

➔ For this observe chapter *Technical data* on page 24.

DISPOSAL

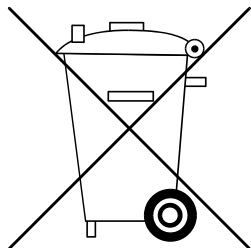

The disposal must comply with the respective national law.

Please enquire about local disposal arrangements at your municipal authority.

Maintenance schedule

WHEN	WHAT	REMARK
Before starting out	General Test for faultless operation.	Carry out test yourself or with a helper.
Before starting out	Test brakes for faultless operation Activate brake lever to the limit.	Carry out test yourself or with a helper. The locked wheels should not be able to turn under operating conditions. If they can still turn, the brakes must be repaired by an authorised specialist workshop.
Before starting out	Check pressure brake for wear Move brake lever to the side.	Carry out tests yourself or have a helper do it. If you notice any increasing slackness on the brake lever take the wheelchair to your specialist workshop immediately for repairs. – Danger of accidents!

MAINTENANCE

An incorrect or neglected cleaning and maintenance of the wheelchair results in a limitation of the product liability.

Maintenance

The following maintenance Instruction gives you a guide for carrying out the maintenance work.

➔ The maintenance plan does not give information about the actual extent of work determined on the wheelchair.

WHEN	WHAT	REMARK
Before starting out	Check tyre profile	Carry out visual check yourself. If the tyre profile is worn down or if the tyre is damaged, consult a specialist workshop for repairs.
Before starting out	Check the back tubes and frame tubes for damages	Carry out the test yourself or by a helper. If deformations or cracks occur in the welding seams, contact a specialist workshop immediately for repairs. – Danger of accidents!
Before starting out (when applicable)	Check air pressure of the tyres Tyre filling pressure: <i>View Tyre pressure of pneumatic tyres on page 24.</i>	Carry out test yourself or with a helper. Use a tyre gauge.
Especially before driving in the dark (when applicable)	Check the lighting Check the light- and indicator signal equipment as well as reflectors for immaculate performance.	Carry out test yourself or with a helper.
Every 8 weeks (depending on frequency of use)	Lubricate the following components with a few drops of oil Moving parts of the locking mechanism. Brake lever bearings.	Do it yourself or with the aid of a helper. Components must be free from used oil residues before lubrication. Please ensure that excess oil does not contaminate the environment (e.g. your clothing).
	Check all screw connections for secure fit	Carry out test yourself or with a helper.
Every 6 months (depending on frequency of use)	Check Cleanness. General condition.	See Care. See Repairs.

TECHNICAL DATA

All data given in the < *Technical data* > refers to the standard version.

The overall length depends on the position and size of the drive wheels.

If not noted otherwise the dimensions are determined with drive wheels of \varnothing 610 mm (24").

The widths were determined with a handrim distance of 15 mm.

Dimensional tolerance ± 15 mm, $\pm 2^\circ$.

Short form of wheelchair dimensions:

SH = Seat height

SW = Seat width

SD = Seat depth

BH = Back support height

Calculation of the max. user weight:

The maximum total load is calculated on the basis of the unloaded weight of the wheelchair and the maximum passenger weight.

Additional weight due to subsequent additions or luggage reduce the maximum permissible passenger weight.

Example:

A driver wishes to take luggage with a weight of 5 kg. Thus, the maximum user weight is reduced by 5 kg.

Tyre pressure of pneumatic tyres

Maximum tyre pressure is printed on the tyres on each side.

Full tyre pressure – steering wheel

Standard:

2.5 - 3.5 bar = 2500 - 3500 hPa = 36 - 50 psi

Full tyre pressure – drive wheel

Standard:

3.0 - 4.0 bar = 3000 - 4000 hPa = 44 - 58 psi

Ultra-light running tyres:

6 bar = 6000 hPa = 87 psi

High pressure:

8 bar = 8000 hPa = 116 psi

Applied norms

The wheelchair complies with the norm:

- EN 12183
- ISO 7176-8
- ISO 7176-19
- ➔ Assessment of the Crashtest, in which the wheelchair is attached to the retaining system of the vehicle, has been carried out according to the testing methods of annex D.
- ➔ The wheelchair has been release for the following anchoring systems:
 - 4-point anchoring system acc. to ISO 10542.
- ➔ The corresponding product accompanying documents are included with the product.
- ➔ The specific document for the anchoring system can also be viewed in the product specific category < *Operating manuals* > on our website < www.meyra.com >.

The applied parts and components we use are in compliance to EN 1021-2 for resistance against inflammation.

Data according to ISO for model 1.750

Eurochair

	min.	max.
Overall length with leg support	1000 mm	1080 mm
Overall width (from a width of 700 mm the wheelchair is not suited for transport on a train)	560 mm	740 mm
Overall dimensions	– kg	148 kg
User weight (incl. additional load)	– kg	130 kg
Weight of the heaviest part	8 kg	9 kg
Actual seat depth	400 mm	460 mm
Actual seat width	380 mm	530 mm
Folding length	1000 mm	1040 mm
Folding width	280 mm	310 mm
Folding height	900 mm	960 mm
Seat surface height at front edge (without cushion)	420 mm	530 mm
Seat angle	0°	4°
Back support angle	90°	100°
Back support belt height	400 mm	420 mm
Foot support to seat (lower shank length)	350 mm	520 mm
Angle leg support - seat surface	111°	111°
Arm support height from seat surface	230 mm	310 mm
Back support to front edge of arm support	280 mm	340 mm

	min.	max.
Handrim diameter	485 mm	540 mm
Axle horizontal position	0 mm	45 mm
Obstacle height	0 mm	100 mm
Minimal turning radius (normative recommendation according to ISO 1000 mm)	1150 mm	– mm
Pivot area	– mm	1300 mm
Weight of the dummy (ISO 7176-8)	– kg	130 kg
<u>Nominal inclination</u>		
Static stability downhill	–°	6°
Static stability uphill	–°	6°
Static stability lateral	–°	6°
Dynamic stability uphill	–°	–°

Further technical data for model 1.750

Eurochair

	min.	max.
Length without leg support	690 mm	730 mm
Overall height	900 mm	960 mm
Seat cushion thickness		30 mm
Length without leg supports, drive wheels (Support castors are removed or swivelled underneath the seat)	610 mm	640 mm

	min.	max.
Additional load	- kg	10 kg
Empty weight	15 kg	18 kg
Transport weight (without leg supports, arm supports, cushion, drive wheels)	8 kg	9 kg
Weight seat cushion	0.9 kg	- kg
Weight leg supports (1 piece)	0.95 kg	- kg
Weight arm supports (1 piece)	0.9 kg	- kg
Weight drive wheels (1 piece)	1.9 kg	- kg
<u>Steering wheel</u>		
ø 125 mm (5")	Solid rubber	
ø 142 mm (5½")	Soft solid rubber	
ø 180 mm (7")	Pneumatic tyres	
ø 180 mm (7")	PU	
<u>Driving wheel</u>		
ø 559 mm (22 x 1 3/8")	PU	
ø 610 mm (24 x 1 3/8")	PU	
<u>Climatic data</u>		
Ambient temperature	-20 °C to +50 °C	
Storage temperature	-30 °C to +60 °C	

Meaning of the symbols on the washing instruction

(the symbols correspond to European standard)



Wash as delicates with the indicated maximum temperature in °C



Wash as regular laundry with the indicated maximum temperature in °C



Hand wash only



Do not bleach



Not suited for the dryer



Do not iron



Do not dry-clean

Meaning of the labels on the wheel-chair



Read the operating manuals and other provided documentation.

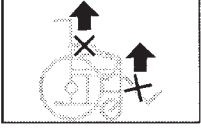

Do not lift the wheelchair at the arm supports or leg supports. Removable parts are not suitable for carrying.



The product is approved as a seat within a motor vehicle.



Anchor point for handicapped transport



The product is **not** approved as a seat within a motor vehicle.



Indication for danger of jamming. – Do not reach in here.

Meaning of the symbols on the type plate



Manufacturer



Order number



Serial number



Production date



Permitted user weight



max. permissible total weight

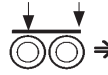

Permitted axle weights



Max. permissible rising gradient



Max. permissible falling gradient

max. ... km/h

Permitted maximum speed



The product is approved as a seat within a motor vehicle.



Max. permitted user weight if the product is approved as a seat within a motor vehicle.



The product is **not** approved as a seat within a motor vehicle.



Medical device



Unique identification of the medical device

WARRANTY / GUARANTEE

Failure to observe the instructions in the operating manual, improperly carried out maintenance work and, especially, technical changes and additions (add-ons) carried out without our prior consent will lead to a general loss of guarantee and product liability.

National warranty- / guarantee conditions between you and your specialist dealer can vary from the conditions mentioned in this chapter.

We accept legal liability for this product within the scope of or general terms and conditions and warranty and in certain cases other verbal resp. agreed upon guarantees. For warranty and guarantee demands please contact your specialist dealer with following Warranty/Guarantee section and the there included information on model description, delivery note number with delivery date and serial number (SN).

The serial number (SN) can be read off of the type plate.

Precondition for the acceptance of liability in any case is the intended use of the product, the use of original spare parts by authorised dealers as well as maintenance and inspections in regular intervals.

Guaranty is not granted for surface damages, tyres of the wheels, damages due to loosened screws or nuts as well as worn out attachment holes due to frequent assembly work.

This operating manual as a part of the product is to be handed out in case of a change of owner.

For evaluation of our products you can use our < Information center > sector < PMS > on our website < www.meyra.com >.

We reserve the right to make technical improvements.



This product fulfils the requirements of the directive (EC) 2017/745 for medical devices.

Warranty / Guarantee section

Please fill out! Copy if necessary and send the copy to the specialist dealer.

Warranty / Guarantee

Model designation:

Delivery note no.:

SN (view type plate):

Date of delivery:

Stamp of the specialist dealer:

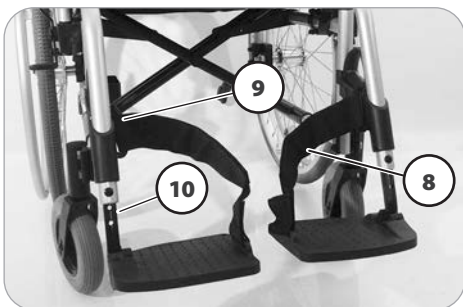
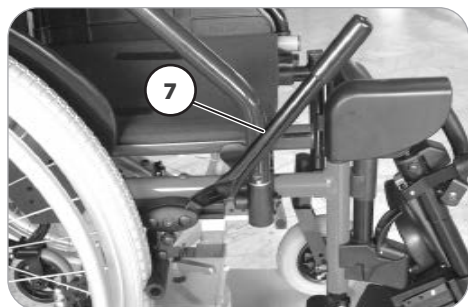
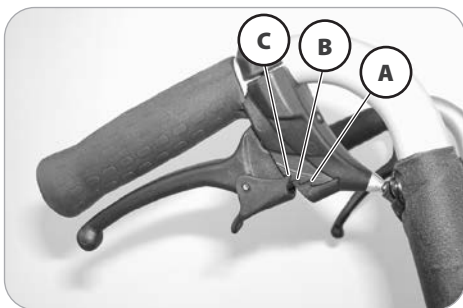
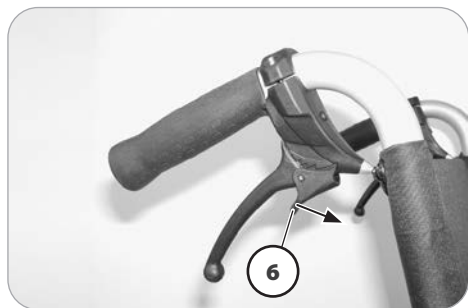
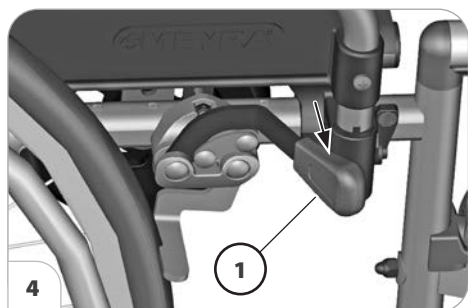
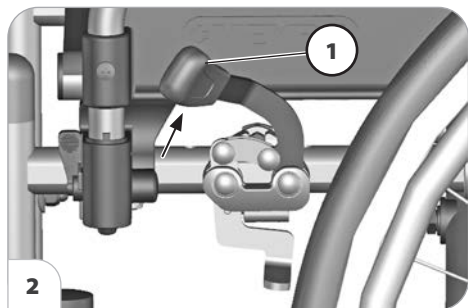

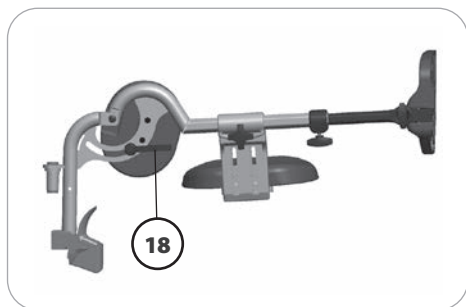
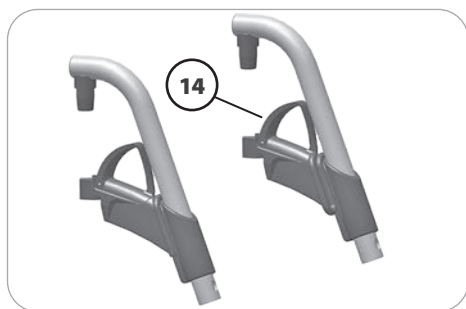

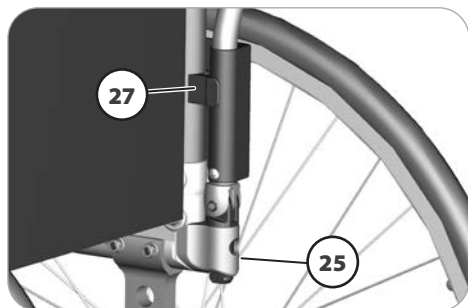
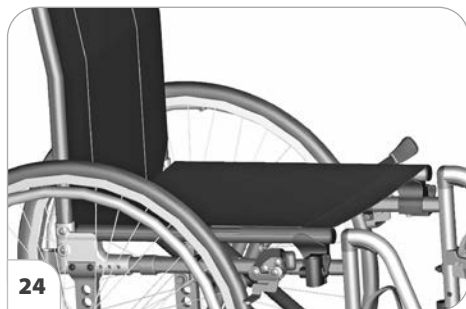
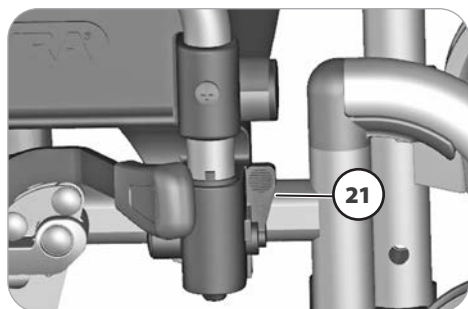
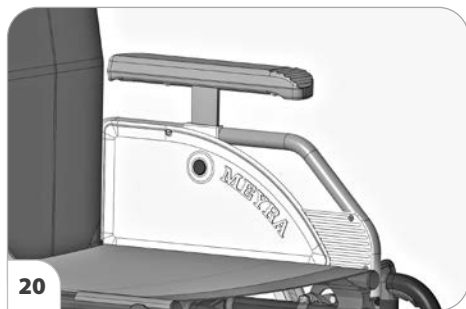
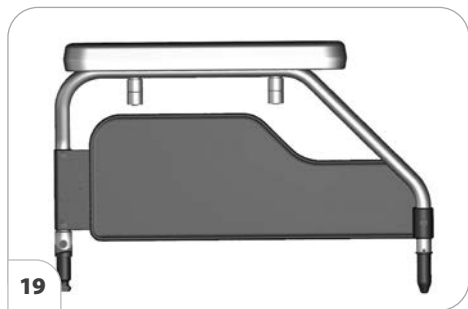

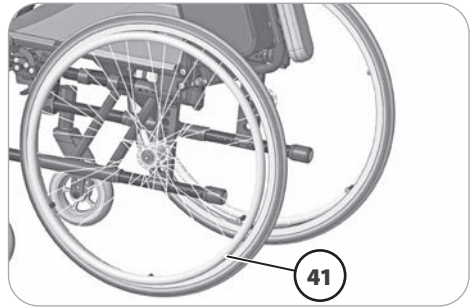
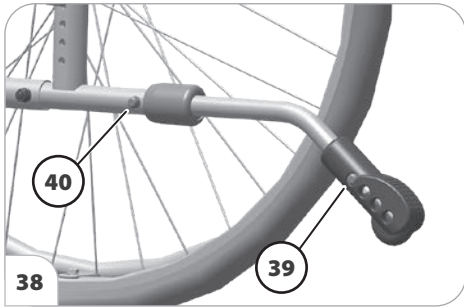
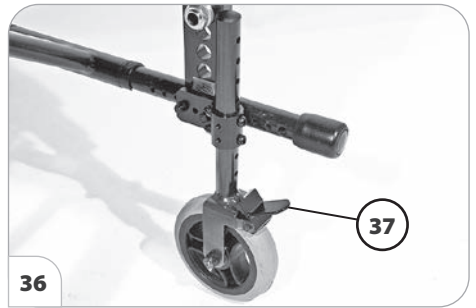
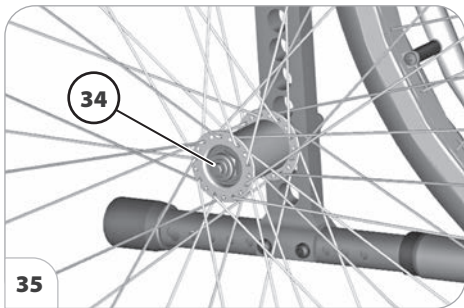
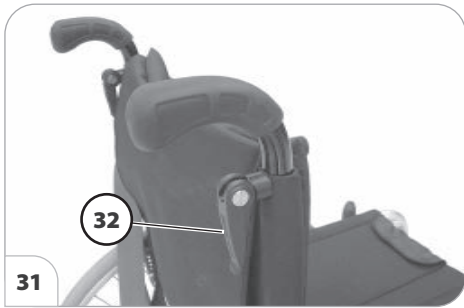

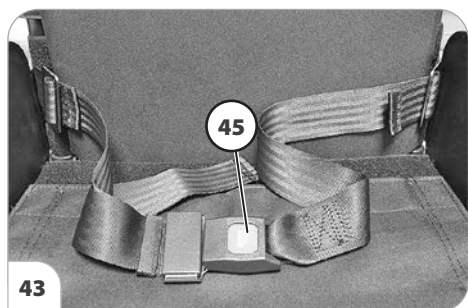

NOTES



Your specialist dealer

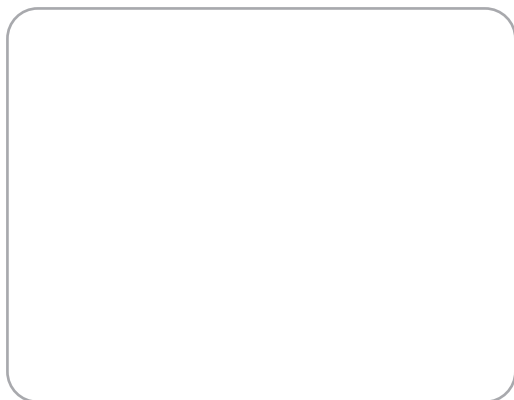

Original
Operating manual

MEYRA GmbH Kleiststraße 49 | 32457 Porta Westfalica | Germany
info@meyragroup.com | Tel.: +49 571 93292 - 311 | Fax: +49 571 93292 - 9311 | www.meyra.de

2025-12 Our products are subject to technical modification. Our printed matter may contain printing errors.
Teile-Nr. 205 350 401