

R82 x:panda seat wedges

Seat wedges create a gentle contour to accommodate the ischial tuberosities and increase the contact area between the user and the cushion, with the overall aim to prevent the pelvis from rolling backward.

Tip!

The seat wedge is often used with a Y-hip belt and sometimes with a lumbar support

Tip!

As the child grows the seat wedges need to be reviewed so that they still offer sufficient support



Steps to customize your seat wedge

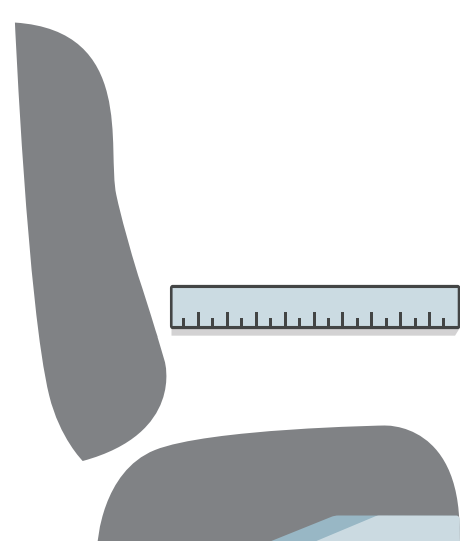

The seat wedge should cover one-half to two-thirds of the seat depth.
Example: Seat depth=30cm, wedge=10-15cm

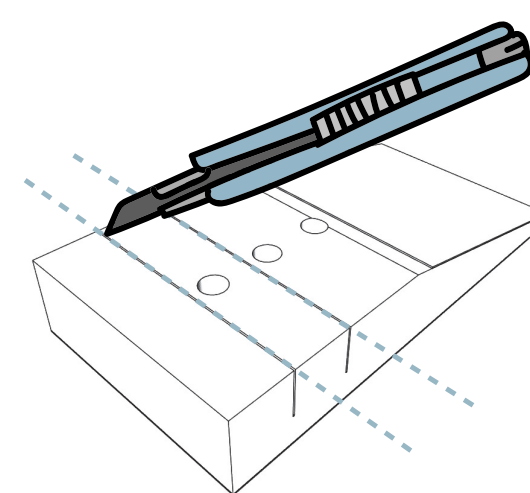

Cut the seat wedge as shown in the assembly instruction